



THIRD EDITION

Guide to _____

CONCRETE OVERLAYS

Sustainable Solutions for Resurfacing and Rehabilitating Existing Pavements

May 2014



A practical approach to understanding and successfully using concrete overlays, from selection to opening

On the Cover



source: Todd Hanson, Iowa DOT



source: Jim Cable, Iowa State University



source: Randell Riley, Illinois chapter, ACPA



source: Kevin Merryman, Iowa DOT



source: The Transtec Group



source: Todd Hanson, Iowa DOT

Technical Report Documentation Page

1. Report No. ACPA Publication TB021.03P	2. Government Accession No.	3. Recipient's Catalog No.	
4. Title and Subtitle <i>Guide to Concrete Overlays: Sustainable Solutions for Resurfacing and Rehabilitating Existing Pavements (3rd edition)</i>		5. Report Date May 2014	
		6. Performing Organization Code	
7. Author(s) Dale Harrington and Gary Fick		8. Performing Organization Report No.	
9. Performing Organization Name and Address National Concrete Pavement Technology Center Institute for Transportation, Iowa State University 2711 South Loop Drive, Suite 4700 Ames, IA 50010-8664		10. Work Unit No. (TRAIS)	
		11. Contract or Grant No.	
12. Sponsoring Organization Name and Address American Concrete Pavement Association 500 New Jersey Ave., NW 7th Floor Washington, DC 20001		13. Type of Report and Period Covered	
		14. Sponsoring Agency Code	
15. Supplementary Notes			
16. Abstract <p>The primary goal of this guide is to fill the knowledge gap about concrete overlays so that pavement owners can confidently include concrete overlays in their toolbox of pavement solutions and make more informed decisions about designing and constructing them. Another goal is to help owner agencies understand and appreciate the versatility of concrete overlay solutions. This is not a complete step-by-step manual, nor does it provide prescriptive formulae or specifications for designing and constructing concrete overlays. Rather, as the title suggests, this booklet provides expert guidance that can supplement practitioners' own professional experience and judgment. In particular, since the 2nd edition was published, this edition enhances original material with updated information on the following topics:</p> <ul style="list-style-type: none"> • Evaluating existing pavements to determine if they are good candidates for concrete overlays • Selecting the appropriate overlay system for specific pavement conditions • Managing concrete overlay construction work zones under traffic • Accelerating construction of concrete overlays when appropriate 			
17. Key Words Pavements – concrete overlays – resurfacing – pavement preservation – pavement rehabilitation		18. Distribution Statement	
19. Security Classification (of this report) Unclassified.	20. Security Classification (of this page) Unclassified.	21. No. of Pages 145 plus front matter and Notes page	22. Price

Guide to Concrete Overlays

Sustainable Solutions for Resurfacing and Rehabilitating Existing Pavements

Third Edition, May 2014

Authors

Dale Harrington, Snyder & Associates, Inc.

Gary Fick, Trinity Construction Management Services, Inc.

Contributing Technical Authors

Amanda Bordelon, PhD, University of Utah

James Cable, PhD, P.E., Cable Concrete Consultation LC

Dan DeGraaf, P.E., Michigan Concrete Paving Association

Nigel Parkes, PNA Construction Technologies, Inc.

Randell Riley, P.E., Illinois Chapter, American Concrete Pavement Association

Rob Rodden, P.E., American Concrete Pavement Association

Jeff Roesler, PhD, P.E., University of Illinois at Urbana-Champaign

Julie Vandenbossche, PhD, P.E., University of Pittsburg

Project Coordinator

Melisse Leopold, Snyder & Associates, Inc.

Managing Editor

Marcia Brink, National Concrete Pavement Technology Center

Copyeditor

Carol Gostele, Birch Tree Editing

Technical Illustrator

Luke Snyder, Snyder & Associates, Inc.

Design and Layout

Mina Shin

About This Guide

This guide is a product of the National Concrete Pavement Technology Center (CP Tech Center) at Iowa State University, with funding from the American Concrete Pavement Association. It is the third edition of the *Guide to Concrete Overlays* since 2007. Complementary publications by the CP Tech Center include the *Guide to the Design of Concrete Overlays Using Existing Methodologies* (October 2012), *Guide to Concrete Overlays of Asphalt Parking Lots* (October 2012), and *Preservation and Rehabilitation of Urban Concrete Pavements Using Thin Concrete Overlays: Solutions for Joint Deterioration in Cold Weather States* (anticipated publication June 2014). The entire series of concrete-overlays related documents is on the CP Tech Center's website, www.cptechcenter.org/.

Acknowledgments

The CP Tech Center gratefully acknowledges the generous financial support of the American Concrete Pavement Association regarding the development and printing of this guide. Without the association's support, there would be no third edition. In addition, the CP Tech Center and the authors wish to thank the knowledgeable, experienced, and dedicated concrete pavement experts, both public and private, who served on the Technical Advisory Committee and contributed to the development of this guide. The committee consists of the following people:

Gina Ahlstrom, P.E., FHWA
Andy Bennett, Michigan Department of Transportation
Tom Burnham, P.E., Minnesota Department of Transportation
Jim Cable, PhD., P.E., Cable Concrete Consultation LC
Dan DeGraaf, P.E., Michigan Concrete Paving Association
Jim Duit, Duit Construction Co., Inc.
Jim Grove, P.E., Senior Project Engineer, FHWA
Todd Hanson, P.E., Iowa Department of Transportation
Kevin Maillard, P.E., OHM Advisors
Kevin Merryman, P.E., Iowa Department of Transportation
Randell Riley, P.E., Illinois Chapter, ACPA
Robert Rodden, P.E., ACPA
Jeff Roesler, PhD, P.E., University of Illinois at Urbana-Champaign
Gordon Smith, P.E., Iowa Concrete Paving Association
Mark Snyder, PhD, P.E., Pennsylvania Chapter, ACPA
Shannon Sweitzer, P.E., North Carolina Turnpike Authority
Sam Tyson, P.E., Federal Highway Administration
Jeff Uhlmeyer, P.E., Washington State Department of Transportation
Julie Vandenbossche, PhD, P.E., University of Pittsburgh
Leif Wathne, P.E., American Concrete Pavement Association
Matt Zeller, P.E., Concrete Paving Association of Minnesota

Abbreviations

AASHTO	American Association of State Highway and Transportation Officials
ACI	American Concrete Institute
ACPA	American Concrete Pavement Association
ASR	alkali-silica reactivity/reaction/reactive
ASTM	American Society for Testing and Materials
CRCP	continuously reinforced concrete pavement
CTE	coefficient of thermal expansion
FAQ	frequently asked question
FHWA	Federal Highway Administration
FRC	fiber-reinforced concrete
FWD	falling weight deflectometer
IRI	International Roughness Index
JPCP	jointed plain concrete pavement
M-E PDG	Mechanistic-Empirical Pavement Design Guide
MRD	material-related distress
MUTCD	Manual on Uniform Traffic Control Devices
NCHRP	National Cooperative Highway Research Program
PCA	Portland Cement Association
PCC	portland cement concrete
SCM	supplementary cementitious material
TRB	Transportation Research Board
TCP	traffic control plan

For More Information

Tom Cackler, Director
Marcia Brink, Senior Editor
National Concrete Pavement Technology Center
Iowa State University Research Park
2711 S. Loop Drive, Suite 4700
Ames, IA 50010-8664
515-294-9480
www.cptechcenter.org/
mbrink@iastate.edu

Mission

The mission of the National Concrete Pavement Technology Center is to unite key transportation stakeholders around the central goal of advancing concrete pavement technology through research, technology transfer, and technology implementation.

For Additional Copies

The American Concrete Pavement Association is distributing this guide. For additional copies, contact your local ACPA chapter or affiliated state paving association (www.acpa.org/ournetwork); ask for ACPA publication no. TB021.03P.

National Concrete Pavement
Technology Center



IOWA STATE UNIVERSITY
Institute for Transportation



Contents

List of Figures.....	ix
List of Tables.....	xii
Ch 1. Introduction.....	1
Two Concrete Overlay (Resurfacing) Options.....	2
Bonded Overlay Option.....	2
Unbonded Overlay Option.....	3
Benefits of Concrete Overlays.....	3
History of Concrete Resurfacing.....	4
Improvements in Concrete Resurfacing Technology.....	4
Sustainability.....	5
Asset Management through Resurfacing Solutions.....	5
Preventive Maintenance.....	6
Minor Rehabilitation.....	6
Major Rehabilitation.....	6
Lessons Learned from Recent Concrete Overlay Projects.....	6
Project Evaluation and Selection.....	6
Concrete Overlay Design.....	7
Plans and Specifications.....	7
Sequence of Construction and Maintenance of Traffic.....	7
Concrete Overlay Construction.....	8
Ch 2. Evaluating Pavements and Selecting Solutions.....	9
Pavement Evaluation Process.....	11
Historical Data and Future Projections (Desk Review).....	12
Visual Examination (On-site Review).....	12
Existing Support and Localized Distress.....	12
Vertical Constraints.....	14
Profile Grade.....	14
Pavement Coring.....	15
Optional Analyses.....	15
Deflection Testing.....	16
Alternative Means of Determining Support Conditions.....	16
Roughness and Surface Friction Tests.....	17
Condition Assessment Profile.....	17
Pavement Evaluation Report.....	17
Selecting Appropriate Concrete Overlay Solution.....	17
Ch 3. Overview of Concrete Overlay Options.....	25
Bonded Concrete Overlay on Asphalt Pavements.....	26
Application and Uses.....	26
Performance.....	27
Keys to Success.....	27
Overlay Process.....	27
Pavement Evaluation.....	27
Overlay Design.....	27
Construction.....	27
Future Repairs.....	27
Key Resources.....	27
Overlay Design.....	27
Construction.....	28
Future Repairs.....	29
Key Resources.....	29
Bonded Concrete Overlay on Composite Pavements.....	30
Application and Uses.....	30
Performance.....	31
Keys to Success.....	31
Overlay Process.....	31
Pavement Evaluation.....	31
Overlay Design.....	31
Construction.....	32
Future Repairs.....	33
Key Resources.....	33
Bonded Concrete Overlay on Concrete Pavements.....	34
Application and Uses.....	34
Performance.....	34
Keys to Success.....	35
Overlay Process.....	35
Pavement Evaluation.....	35
Overlay Design.....	36
Construction.....	36
Future Repairs.....	37
Key Resources.....	37
Unbonded Concrete Overlay on Asphalt Pavements.....	38
Application and Uses.....	38
Performance.....	39
Keys to Success.....	39
Overlay Process.....	39
Pavement Evaluation.....	39
Overlay Design.....	39
Construction.....	40
Future Repairs.....	41
Key Resources.....	41
Unbonded Concrete Overlay on Composite Pavements.....	42
Application and Uses.....	42
Performance.....	43
Keys to Success.....	43
Overlay Process.....	43
Pavement Evaluation.....	43
Overlay Design.....	43
Construction.....	44
Future Repairs.....	45
Key Resources.....	45

Contents, continued

Unbonded Concrete Overlay on Concrete Pavements	46	Measurement and Payment Items for Concrete Overlays.....	63
Application and Uses	46	Establishing Plan Quantity for Overlay Concrete	63
Performance	47	Typical Costs of Concrete Overlays	64
Keys to Success	47	Miscellaneous Design Details	64
Overlay Process.....	47	Curb and Gutter Details.....	64
Pavement Evaluation	47	Leaving the Existing Curb in Place	64
Overlay Design	47	Removing Curb and Gutter	64
Construction	48	Overlay Curb.....	64
Future Repairs	49	Vertical Grade Changes	65
Key Resources.....	49	Overhead Clearance	65
Ch 4. Concrete Overlay Design	51	Barriers and Rails	65
Concrete Overlay Design Variables.....	51	Safety Edge	65
Existing Pavement Characterization.....	51	Cross Road Drainage Structures	65
Surface Considerations	51	Cross Slope and Superelevation	65
Structural Considerations	52	In-place Pavement Structures.....	66
Traffic Characterization.....	52	Plate Dowel Details	66
Material Properties.....	52	Corrosion Resistance	67
Climatic Factors.....	53	Plate Dowel Installation for Construction Joints Formed with a Bulkhead (Form).....	67
Distress Mode.....	53	Plate Dowel Installation in Slipform or Full-depth Saw Cut (Butt-type) Construction Joints	67
Thickness Design Selection.....	53	Dowel Installation for Contraction Joints	68
Background of Design Methodologies	53	Transitions.....	69
ACPA BCOA Method	53	Mill and Fill Transitions for Bonded Concrete Overlays.....	69
BCOA-ME Method.....	55	Transition Details for Bonded Concrete Overlays	69
1993 AASHTO Guide Method	55	Transition Details for Unbonded Concrete Overlays.....	70
AASHTO Pavement ME Design Guide Method	56	Widening and Lane Addition	71
ACPA StreetPave Method	56	Typical Drainage Outlets for Interlayers	73
Slabs with Optimized Geometry and OptiPave2™ Design Software.....	57	Rural Conditions.....	73
Design Considerations for Bonded Overlay Systems	57	Urban Conditions.....	74
Bonded Overlays of Asphalt and Composite Pavements	57	Ch 5. Concrete Overlay Materials and Mixtures.....	75
Bonded Overlays of Concrete Pavements.....	58	Primary Concrete Materials.....	75
Design Considerations for Unbonded Overlay Systems	58	Cementitious Materials	75
Unbonded Overlays of Concrete Pavements	59	Aggregates	75
Suitability of Existing Pavement as a Base	59	Admixtures.....	76
Interlayer	59	Conventional Concrete Mixtures.....	76
Drainage of Interlayer	60	Low w/cm Ratio	76
Joint Design.....	61	Adequate Air Void System	76
Unbonded Overlays of Asphalt Pavements.....	62	Accelerated Mixtures	76
Unbonded Overlays of Composite Pavements	62	Other Materials.....	77
Plan Development.....	62	Structural Fibers for Concrete Overlays	77
Engineering Survey	62	Separation Layer Materials.....	78
Survey Methods.....	62	Asphalt Separation Layer	78
Laser Scanning	63	Nonwoven Geotextile Separation Layer	79

Contents, continued

Dowel Bars and Tiebars	80	Rubblization of Concrete Pavement	111
Joint Sealant	80	Crack and Seat (Not Recommended)	112
Curing Compound.....	80		
Ch 6. Concrete Overlay Strategies in Work Zones	81	Appendix C. Fiber Reinforcement	113
Objectives of Work Zone Management	81	Why Fibers?	113
Safety.....	82	Types of Fibers	113
Traffic Flow	82	High-volume Macro Synthetic Fiber Mixtures.....	114
Cost Effectiveness.....	82	Construction Considerations When Using Fibers.....	114
Work Zone Space Considerations.....	82		
Conventional Paving Equipment Clearances	82	Appendix D. Laser Scanning Survey.....	116
Reducing Clearances.....	83	Roadway Surface 3-D Laser Scanning	116
Other Clearances.....	85	Scanning Applications to Pavements	116
Construction Traffic Control.....	85	Planning Items to Be Considered	116
Concrete Overlay Staging.....	85	Data Analysis	117
Two-Lane Highway under Traffic	85	Static Scanning Operation.....	118
Temporary Safety Fillet.....	86	Mobile 3-D Laser Scanning.....	118
Pilot Cars for Continuous Production	86	Mobile Mapping Operations.....	118
Examples of Staging Sequences.....	86		
Two-Lane Highway Expanded to Three Lanes under Traffic	86	Appendix E. Factors for Constructing Concrete	
Four-Lane Divided Highway without Crossovers and under		Overlays Under Traffic.....	119
Traffic.....	87		
Ch 7. Construction of Concrete Overlays	99	Appendix F. Stringless Paving Operation	127
Key Points for Concrete Overlay Construction.....	99	Horizontal and Vertical Control Requirements and System	
Bonded Overlays: Ensuring Proper Bond	102	Limitations.....	127
Unbonded Overlays: Installation of Geotextile Interlayer Fabric.....	103	Three-step Process for Stringless Paving.....	128
Placing Dowel Baskets.....	104	Existing Stringless Control Systems	129
Curing Concrete Overlays	105	System No. 1	129
Sawing Joints.....	105	System No. 2	130
Accelerated Construction	105	System No. 3	130
Opening Overlay to Traffic.....	106	Stringless System Equipment Selection Criteria.....	131
Minimizing Early Loading Fatigue Damage.....	106		
Strength Conversions	106	Appendix G. Considerations for Developing Project	
Strength Criteria for Opening Bonded Overlay Systems	106	and Supplemental Specifications	132
Bonded on Concrete.....	106	General	132
Bonded on Asphalt.....	106	Contractor Submittal Considerations	132
Strength Criteria for Opening Unbonded Overlay Systems.....	106	Scheduling and Conflicts.....	132
Repairs of Concrete Overlays	107	Limitations of Operations	132
Repairs of Bonded or Thin Unbonded Concrete Overlays	107	Method of Measurement and Basis of Payment	132
Repairs of Full-Depth Unbonded Concrete Overlays.....	108	Materials	132
		Separation Layer for Unbonded Overlays	133
Appendix A. Evaluation and Selection Tables	109	Construction.....	133
Appendix B. Reconstruction Options for Concrete.....	111	Preoverlay Repairs.....	133
In-place Recycled Concrete as a Processed Base Material	111	Bonded Concrete Overlays Over Concrete	133
		Bonded Concrete Overlays Over Asphalt.....	133
		Unbonded Overlays Over Concrete	133
		Unbonded Concrete Overlays Over Asphalt	133

Contents, continued

Surface Cleaning.....	133	Bonded Overlays Over Asphalt.....	134
Bonded Concrete Overlays Over Concrete or Asphalt	133	Unbonded Overlays.....	134
Unbonded Concrete Overlays Over Concrete or Asphalt.....	133		
Concrete Placement.....	133	Appendix H. Suggested Owner-Contractor Meetings	
Grade Control	133	to Ensure a Quality Product	135
Overlay Placement.....	133	Prebid Meeting Check List.....	135
Liquid Membrane Curing.....	134	Prebid Meeting.....	135
Joint Sawing.....	134	Prepour/Preconstruction Review Checklist.....	135
General.....	134		
Joint Width	134	Appendix I. Innovative Methods for Accelerated	
Joint Seal	134	Concrete Overlay Construction	138
Timing	134	References	141
Bonded Overlays Over Concrete	134	Bibliography	144

List of Figures

Figure 1.	Typical concrete overlay (before and after concrete overlay placement)	1	Figure 26.	Bonded concrete overlay of good condition concrete pavement with surface distresses	34
Figure 2.	Types of concrete overlays	2	Figure 27.	Bonded concrete on concrete	34
Figure 3.	Milling concrete (left) and milled surface (right)	3	Figure 28.	Photo of concrete pavement with shotblast surface prior to concrete overlay in 1994.....	35
Figure 4.	Forty-six states where concrete overlays have been constructed (shaded in blue).....	4	Figure 29.	Three-inch concrete bonded overlay (photo dated 2013)	35
Figure 5.	Appropriate preservation solutions at various stages of pavement service life	5	Figure 30.	Width of transverse joint in bonded concrete overlay on concrete pavement should be equal to or greater than width of crack in existing pavement	36
Figure 6.	Typical bonded and unbonded concrete solutions at various stages of pavement service life.....	6	Figure 31.	Crack cage over concrete pavement crack	37
Figure 7.	Pavement evaluation process, with examples of existing pavement conditions	10	Figure 32.	Unbonded concrete overlay (previously called conventional whitetopping) of poor-to-deteriorated condition asphalt pavement.....	38
Figure 8.	Examples of existing pavement conditions, from a condition assessment profile	11	Figure 33.	Unbonded concrete overlay of asphalt pavement	38
Figure 9.	Visual inspection for MRD deterioration at the edge of pavement	13	Figure 34.	Poor to deteriorated asphalt pavement to be resurface.....	39
Figure 10.	Moderate ASR cracking along the perimeter of slab ...	13	Figure 35.	Poor to deteriorated asphalt pavement resurfaced with unbonded concrete overlay.....	39
Figure 11.	D-cracked pavement	14	Figure 36.	Consider asphalt rut depth when determining saw-cut depth.....	41
Figure 12.	Typical joint deterioration with HMA patch	14	Figure 37.	Unbonded concrete overlay of poor-to-deteriorated condition composite pavement.....	42
Figure 13.	Dynamic cone penetrometer	16	Figure 38.	Unbonded overlay of composite	42
Figure 14.	Selecting appropriate concrete overlay solution for asphalt pavements	18	Figure 39.	Composite pavement prior to unbonded concrete overlay.....	43
Figure 15.	Selecting appropriate concrete overlay solution for composite pavements	20	Figure 40.	Unbonded concrete overlay over composite pavement	43
Figure 16.	Selecting appropriate concrete overlay solution for concrete pavements	22	Figure 41.	Consider asphalt rut depth when determining saw-cut depth.....	45
Figure 17.	Bonded concrete overlay of fair or better asphalt pavement with surface distresses (previously called ultra-thin whitetopping).....	26	Figure 42.	Unbonded concrete overlay of poor condition concrete pavement.....	46
Figure 18.	Bonded overlay of asphalt pavement.....	26	Figure 43.	Unbonded concrete on concrete	46
Figure 19.	SH-119 in 1991 prior to placement of an bonded concrete overlay.....	27	Figure 44.	Route D35 existing pavement in poor condition.....	47
Figure 20.	SH-119 in 2009 after 18 years of service	27	Figure 45.	Route D35 5-inch unbonded overlay	47
Figure 21.	Longitudinal joints should be arranged to avoid wheel paths	28	Figure 46.	Overlay design factors that affect one another	51
Figure 22.	Bonded concrete overlay of fair or better condition composite pavement with asphalt surface distresses	30	Figure 47.	Illustration of structural capacity loss over time and with traffic.....	56
Figure 23.	Bonded overlay of asphalt.....	30	Figure 48.	Width of overlay joint saw cut must be greater than the crack width in the existing pavement.....	58
Figure 24.	Existing composite pavement	31			
Figure 25.	Bonded on composite pavement.....	31			

List of Figures, continued

Figure 49.	Upper sketch shows concrete overlay locking up with old pavement (keying), and lower sketch shows interlayer separates overlay from existing pavement. ...	59
Figure 50.	Geotextile fabric separation layer.....	60
Figure 51.	White geotextile fabric interlayer.....	60
Figure 52.	Overlay blowup where expansion joint should have been cut over existing concrete expansion joint	60
Figure 53.	Asphalt stripping of interlayer	61
Figure 54.	Tapered plate dowel baskets in transverse contraction joints and football-shaped plate dowels for slipformed longitudinal construction joints.....	61
Figure 55.	Higher shrinkage restraint in joint intersection with round dowel (left) versus joint intersection with plate dowel (right)	61
Figure 56.	Digital terrain model acquired through laser scanning.....	63
Figure 57.	Concrete overlay cost by thickness.....	64
Figure 58.	Milling detail when leaving the existing curb in place.....	64
Figure 59.	Milling detail when removing and replacing curb.....	64
Figure 60.	Detail of curb overlay	64
Figure 61.	Concrete curb overlay.....	64
Figure 62.	Typical safety edge for concrete overlay without paved shoulder	65
Figure 63.	Dowel options in superelevation areas	65
Figure 64.	Concrete overlay with standard manhole.....	66
Figure 65.	Diamond-shaped plate dowels in fixed-formed construction joints (right side) and football-shaped dowels by slipforms	66
Figure 66.	Detail of construction joint plate dowel for fixed-form paving.....	67
Figure 67.	Taper-shaped construction joint plate dowel using fixed forms	67
Figure 68.	Detail of construction joint plate dowel for slipform paving	67
Figure 69.	Slots being cut to accept the football-shaped plate dowels	67
Figure 70.	Detail of plate dowel for contraction joint.....	68
Figure 71.	Plan view of roadway with plate dowels.....	68
Figure 72.	Mill and fill transition for concrete overlay of concrete pavement.....	69
Figure 73.	Mill and fill transition for concrete overlay of asphalt or composite pavement	69
Figure 74.	New transition tapers used to meet bridge approach slabs or maintain clearance under bridges with bonded overlay of concrete pavement.....	69
Figure 75.	New transition tapers used to meet bridge approach slabs or maintain clearance under bridges with bonded overlay of asphalt pavement	69
Figure 76.	New transition tapers used to meet bridge approach slabs or maintain clearance under bridges with unbonded overlay of concrete pavement.....	70
Figure 77.	New transition tapers used to meet bridge approach slabs or maintain clearance under bridges with unbonded overlay of asphalt pavement.....	70
Figure 78.	Temporary granular transition to existing side road/driveway.....	70
Figure 79.	Asphalt wedge transition to existing side road/driveway.....	70
Figure 80.	Bonded overlay of concrete pavement with widening unit.....	71
Figure 81.	Bonded overlay of asphalt or composite pavement with widening unit.....	71
Figure 82.	View of tiebars for concrete overlay widening unit	71
Figure 83.	Unbonded overlay of concrete, asphalt, or composite pavement with widening unit	72
Figure 84.	Bonded or unbonded overlay of asphalt or composite pavement (previously widened with asphalt or concrete, and to be widened again with new concrete overlay) ..	72
Figure 85.	Unbonded overlay of concrete, asphalt, or composite pavement with full concrete lane addition	72
Figure 86.	Interlayer outlet for concrete overlay shoulder	73
Figure 87.	HMA interlayer outlet for asphalt shoulder	73
Figure 88.	Geotextile interlayer outlet with new paved shoulder (concrete or asphalt)	73
Figure 89.	Drainage of separation layer (interlayer) into an existing underdrain system when existing curb is removed and replaced.....	74
Figure 90.	Drainage of separation layer fabric into intake when curb is not removed	74
Figure 91.	Synthetic fibers (1.5 in. to 2.25 in.).....	77
Figure 92.	Geotextile separation layer.....	79
Figure 93.	Light-colored geotextile fabric used as a separation layer for an unbonded overlay	79

List of Figures, continued

Figure 94.	Managing work zones effectively involves balancing several priorities.....	81	Figure 116.	Removing overlay panels	107
Figure 95.	Stringline paver	83	Figure 117.	Finish and cure of concrete overlay repair	107
Figure 96.	A three-track, zero-clearance paver placing concrete along a median barrier.....	83	Figure 118.	Typical concrete pavement milling operation	107
Figure 97.	A typical four-track paver modified to three tracks, providing zero clearance in a C/G situation in Oklahoma	83	Figure 119.	Typical concrete pavement milling operation	107
Figure 98.	Controlling paving profile using a moveable stringline on the adjacent lane	84	Figure 120.	Typical concrete pavement millings from milling operation.....	108
Figure 99.	Controlling paving profile using a paver ski on the adjacent lane	84	Figure 121.	Recycled concrete aggregate.....	111
Figure 100.	Stringless paver.....	84	Figure 122.	Rubblized concrete pavement.....	111
Figure 101.	Zero clearance stringless paver.....	84	Figure 123.	Fibers in concrete mix	113
Figure 102.	Vertical traffic control panels may be used to mark pavement edge dropoff.....	86	Figure 124.	Fibers added at plant (left) and bags tossed into ready-mix truck (right)	114
Figure 103.	Centerline safety edge fillets for overlays 3 in. (50 mm) or greater.....	86	Figure 125.	Finished concrete overlay with synthetic fibers	115
Figure 104.	Overlay of two-lane roadway with paved shoulders (conventional paver).....	88	Figure 126.	Balling fibers	115
Figure 105.	Overlay of two-lane roadway with granular shoulders (conventional paver).....	90	Figure 127.	Typical mobile scan project workflow.....	117
Figure 106.	Overlay of two-lane roadway with minimum granular shoulders (zero-clearance paver).....	92	Figure 128.	Pavement DTM/detail	117
Figure 107.	Overlay of two-lane roadway widening to three lanes with paved shoulder (conventional paver)	94	Figure 129.	Pavement cross section detail.....	117
Figure 108.	Overlay of four-lane roadway with paved shoulders (conventional paver).....	96	Figure 130.	Static laser scanner.....	118
Figure 109.	Compare the surface texture of the nonshotblasted area (upper left half of image) to the roughened surface texture on the shotblasted section of pavement (under the pen)	102	Figure 131.	Mobile laser scanner	118
Figure 110.	Overlap of nonwoven geotextile material section	103	Figure 132.	Mobile scanner onboard quality control operation area.....	118
Figure 111.	Fastening nonwoven geotextile fabric to existing concrete pavement.....	103	Figure 133.	Paving machine control	127
Figure 112.	Paving on top of nonwoven geotextile materials	104	Figure 134.	Survey existing surface to develop and build database.....	128
Figure 113.	Paving on top of white geotextile fabric interlayer	104	Figure 135.	ATV with GPS and laser profile	128
Figure 114.	Dowel basket anchor nails should be placed on the downstream side of the basket relative to the direction of pavement.....	104	Figure 136.	Total robotic station	129
Figure 115.	Manually verifying dowel placement	104	Figure 137.	System 1—Stringless paving operation using total stations and reference points.....	129
			Figure 138.	Computer controls on paving machine.....	129
			Figure 139.	Rotating laser over reference points	130
			Figure 140.	System 2 paving machine	130
			Figure 141.	System 2—Stringless paving operation using GPS, a rotating laser, and reference points	130
			Figure 142.	GPS base station mobile or fixed	131
			Figure 143.	GPS paver control system.....	131
			Figure 144.	System 3—Stringless paving operation using GPS....	131

List of Tables

Table 1.	Recommended Optional Testing	15	Table 14.	Size and Spacing of Plate Dowels for Contraction Joints.....	66
Table 2.	Subgrade Soil Types and Approximate Support Values.....	17	Table 15.	The Effect of Aggregate Gradation on Mixture Properties	75
Table 3.	Possible Preoverlay Repairs on Existing Asphalt Pavement in Preparation for Bonded Overlay.....	28	Table 16.	Slab Thickness and Opening Strength	77
Table 4.	Possible Preoverlay Repairs on Existing Composite Pavement in Preparation for Bonded Overlay.....	32	Table 17.	Summary of Fiber Types.....	78
Table 5.	Possible Preoverlay Repairs on Existing Concrete Pavement in Preparation for Bonded Overlay.....	37	Table 18.	Michigan DOT Asphalt Separation Layer Gradation..	78
Table 6.	Possible Preoverlay Repairs on Existing Asphalt Pavement in Preparation for Unbonded Overlay	40	Table 19.	Geotextile Separation Layer Material Properties	79
Table 7.	Possible Preoverlay Repairs on Existing Composite Pavement in Preparation for Unbonded Overlay	44	Table 20.	Concrete Overlay Work Zone Management Considerations	81
Table 8.	Typical Transverse Joint Spacing.....	48	Table 21.	Concrete Paving Construction Practices for Overlays	99
Table 9.	Possible Preoverlay Repairs on Existing Concrete Pavement in Preparation for Unbonded Overlay	49	Table 22.	Distress Types and Severity Levels Recommended for Assessing Concrete Pavement Structural Adequacy	109
Table 10.	Summary of Current Overlay Design Software	54	Table 23.	Distress Types and Levels Recommended for Assessing Asphalt and Composite Pavement Structural Adequacy	110
Table 11.	Typical Weight and Thickness for Geotextile Interlayer.....	60	Table 24.	Considerations for Concrete Overlay Construction under Traffic.....	119
Table 12.	Typical Adjustment Factors for Estimating Overlay Cubic Yard Plan Quantities.....	63	Table 25.	Applicability, Pros, and Cons of Various Accelerated Construction Methods	138
Table 13.	Size and Spacing of Plate Dowels for Construction Joints.....	66			

Chapter 1.

INTRODUCTION

The need has never been greater for engineered strategies to preserve and maintain the nation's pavements. With shrinking budgets, ever-increasing traffic volumes and loads, and the critical emerging focus on infrastructure sustainability and pavement preservation, highway agencies are being asked to do more with less in managing their pavement networks. Concrete overlays can serve as sustainable and cost-effective solutions for improved management of pavement assets, including preservation, resurfacing, and rehabilitation. In addition, they contribute to more sustainable construction practices by preserving and extending pavement service for years beyond the original design life. Many concrete overlays have been in service for decades, effectively extending the life of the original pavement structures for 30 years or more.

To ensure that concrete overlays provide durable, long-lasting maintenance and rehabilitation solutions, good design and construction practices must be followed. These include designing an overlay that is appropriate for the situation, accomplishing appropriate pre-overlay repairs and preparation of the existing pavement, and using good construction practices like proper jointing and curing. With thorough planning, work zones can be managed to accommodate these activities without sacrificing project safety, traffic flow, or cost effectiveness.

Despite a demonstrated history of hundreds of successful concrete overlay projects, some

agencies and contractors have hesitated to design and construct them. One reason may be a lack of understanding of engineered concrete overlays. The primary goal of the *Guide to Concrete Overlays* series, therefore, is to fill the knowledge gap and answer pavement owners' questions so that they can confidently include concrete overlays in their toolbox of pavement solutions and make more informed decisions about designing and constructing them. The first (Harrington et al. 2007) and second (Harrington 2008) editions of this guide described concrete overlay types, applications, and issues related to design and construction. This third, expanded edition enhances the original material with updated information:

- Evaluating existing pavements to determine if they are good candidates for concrete overlays
- Selecting the appropriate overlay system for specific pavement conditions
- Managing concrete overlay construction work zones under traffic
- Accelerating construction of concrete overlays when appropriate

Like the first and second editions, however, this guide is not a complete step-by-step manual, nor does it provide prescriptive formulae or specifications for designing and constructing concrete resurfacing projects. As the title suggests, this booklet provides expert guid-

ance that can supplement practitioners' own professional experience and judgment.

Another goal of this guide is to help owner agencies understand and appreciate the versatility of concrete overlay solutions. A common misconception is that concrete overlays are limited to projects that require long-term solutions (20 to 35 years) and that other options may be better suited for short-term solutions (5 to 15 years). Another is that overlays are expensive or difficult to build, or are niche solutions with limited applicability. In actuality, however, the following statements are true:

- Concrete overlays can be designed to cost effectively accommodate all combinations of design life and traffic loading. Their thickness can vary from 2 to 10 inches or greater, depending on the existing pavement condition, anticipated traffic, available funding, and desired design life.
- Concrete overlay solutions exist for all pavement types (concrete, asphalt, and composite [asphalt surfacing over concrete]).
- Concrete overlay solutions exist for all pavement conditions; see Figure 1. Because concrete distributes traffic loads over a wide area, the underlying pavement does not experience highly concentrated stresses. As a result, as long as the original pavement remains stable and uniform, a concrete overlay can be placed.



Figure 1. Typical concrete overlay (before [left] and after concrete overlay placement)

Two Concrete Overlay (Resurfacing) Options

As Figure 2 illustrates, there are two options regarding concrete overlays: bonded and unbonded. This guide uses the general term “concrete resurfacing” when collectively discussing both bonded and unbonded concrete overlay solutions.

Bonded overlays are designed as part of the pavement thickness, whereas unbonded overlays are essentially new pavement on a stable base (existing pavement). Bonded overlay options require that the existing pavement be in good to fair structural condition. The overlay helps eliminate surface distresses, with the new overlay and existing pavement acting as a monolithic pavement. Unbonded overlay options add structural capacity to the existing pavement system and do not require bonding to the existing pavement. Unbonded overlays can be placed on poor or even deteriorated pavements that are uniform. As shown

in Figure 2, both bonded and unbonded overlays can be placed on existing asphalt, composite, or concrete pavements.

Bonded Overlay Option

The purpose of bonded concrete overlays is to add structural capacity and eliminate surface distresses on existing pavements that are in good to fair structural condition. Bonded overlays generally provide resurfacing solutions for routine or preventive pavement maintenance and for minor rehabilitation.

Bonded concrete overlays are relatively thin (2–6 in. [50–150 mm]). Bonded together, the overlay and the existing pavement perform as one monolithic pavement. Bonding between the overlay and the existing pavement is essential. The bond ensures that the overlay and existing pavement perform as one structure, with the original pavement continuing to carry a significant portion of the load. All bonded overlay projects, therefore, are carefully designed and constructed to achieve and maintain a bond between the overlay and the existing pavement.

Factors that affect the performance of the resurfaced pavement include the structural integrity of the underlying pavement, the effectiveness of the bond, the ability of the two layers to move monolithically to maintain the bond, and overlay jointing and curing techniques.

The key to achieving desired performance is to ensure the two structures—the existing pavement and the overlay—behave as one structure. Therefore, it is important to understand movement-related properties, such as expansion and contraction properties, of both the existing pavement and the overlay. For example, for a bonded concrete overlay of an existing concrete pavement, the coefficient of thermal expansion (CTE) of the overlay concrete mixture should be similar to or less than that of the existing concrete pavement.

Most bonded overlay projects are more challenging than unbonded overlay projects. Therefore, it is important to pay close attention to details in this guide.

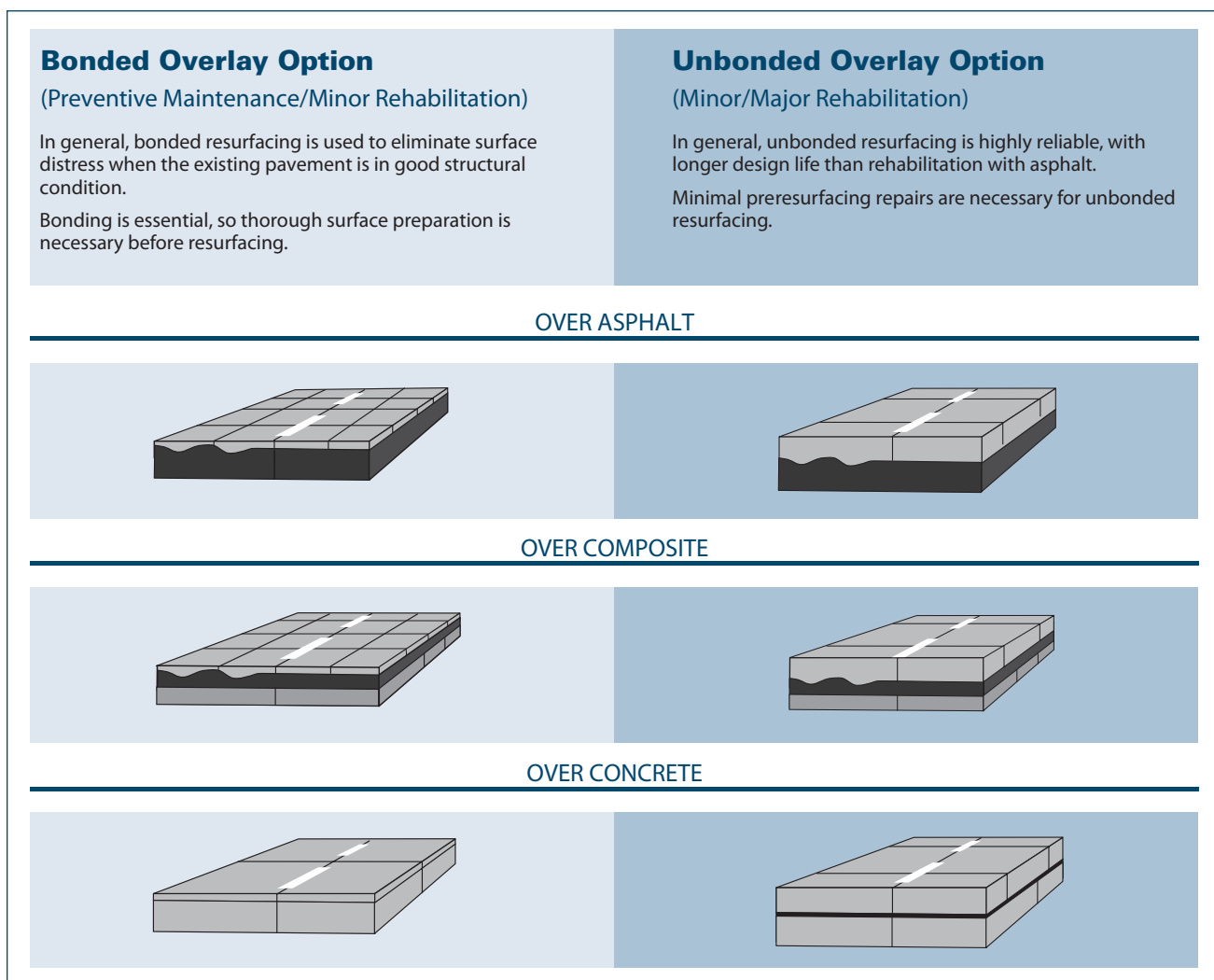

Figure 2. Types of concrete overlays

Unbonded Overlay Option

The purpose of an unbonded overlay is to restore structural capacity to an existing pavement that is moderately to significantly deteriorated. Unbonded overlays are minor or major rehabilitation strategies.

The term “unbonded” simply means that bonding between the overlay and the underlying pavement is not needed to achieve the desired performance (i.e., the thickness design procedure does not consider the existing pavement as a structural component of the surfacing layer). Thus, the overlay performs as a new pavement, and the existing pavement provides a stable base. When the underlying pavement is asphalt or composite, partial or full bonding between the concrete overlay and the underlying asphalt layer should not cause a problem. In fact, such bonding generally adds some load-carrying capacity to the system. So, unbonded concrete overlays on existing asphalt or composite pavements are not rigorously designed and constructed to prevent bonding between the layers.

When the underlying pavement is concrete, however, unbonded concrete overlays are carefully designed and constructed to prevent bonding between the two concrete layers. That is because any bonding between the two concrete layers may stress the overlay and result in undesired reflective cracking.

Benefits of Concrete Overlays

Agencies that regularly construct concrete overlays derive several benefits:

1. Concrete overlays consistently provide cost-effective solutions.
 - a. Dollar for dollar, they are one of the most effective long-term pavement preservation and major rehabilitation options for existing pavements.

FAQ—Can concrete pavement actually be milled efficiently?

Yes. While not commonly done, several large projects in the recent past have utilized milling as a means to remove up to 4 inches of the existing concrete pavement prior to constructing a concrete overlay, as shown in Figure 3, or, in limited cases, to repair an existing concrete overlay. Modern milling machines can effectively remove concrete at production rates similar to asphalt pavement; efficiency and production are influenced primarily by the depth of cut and hardness of the aggregate.

2. Concrete overlays can be constructed quickly and conveniently.
 - a. The existing pavement does not need to be removed. In fact, it is factored into the overlay design to continue to help carry some of the traffic load.
 - b. In most cases, minimal preoverlay repairs are necessary.
 - c. Concrete overlays are placed using normal concrete pavement construction practices.
 - d. Many concrete overlays can be opened to traffic within a day of placement. Nondestructive strength indicators, like maturity testing, enable engineers to take advantage of this benefit.
 - e. Accelerated construction practices can be used. This guide provides useful recommendations for coupling concrete overlay construction with accelerated construction techniques.
3. Concrete overlays are easy to maintain.
 - a. Repairing concrete overlays, especially thin overlays, is usually much easier than repairing a section of conventional pavement.
 - b. Thin overlays constructed without reinforcement can be easily and economically milled out and replaced with a new concrete surface.
 - c. Utility repair locations can be restored to original surface elevation and ride quality with ease.
4. Concrete overlays are an effective means to enhance pavement sustainability by improving surface reflectance (albedo), increasing structural longevity, enhancing surface profile stability, and maintaining ride quality.
5. Concrete overlays can serve, in and of themselves, as complete preventive maintenance, preservation, or rehabilitation solutions.



Figure 3. Milling concrete (left) and milled surface (right)

History of Concrete Resurfacing

Use of portland cement concrete (“concrete”) to resurface existing pavements can be traced to as early as 1901. By the mid-1980s, many new concrete overlays were being constructed, and the technology was rapidly maturing into a standard practice in some agencies. A 1994 National Cooperative Highway Research Program (NCHRP) *Synthesis of Practice 204* showed that a relatively low-maintenance service life of 20 years can be expected and that many resurfacings have provided 30 to 40 years of service.

With the inclusion of data from NCHRP Syntheses 99 and 204 (1982, 1994) the American Concrete Pavement Association’s (ACPA) National Concrete Overlay Explorer (2013a) provides the best historical information on the use of concrete overlays in the United States. This database documents the construction of 1,152 concrete overlays in the United States from 1901 through 2012. Concrete resurfacings have undergone an impressive growth, which is evident in the number of documented resurfaced highways in service in the last three decades. Between 1980 and 2010, five times as many concrete overlay projects were constructed per decade as were constructed in the previous six decades.

This growth is evidence that concrete overlays are a good investment for highway agencies seeking an additional preservation or major rehabilitation alternative. Jointed plain and reinforced concrete overlays in service throughout the country are bonded,

unbonded, and partially bonded overlays of concrete pavements. Many plain and a few reinforced overlays also are in service as overlays of asphalt concrete pavements, especially in heavy trucking corridors. Concrete overlays have been successfully constructed in 46 different states; see Figure 4.

Improvements in Concrete Resurfacing Technology

Many of the changes and improvements in the technology foreseen in the earlier reviews have been realized as the highway community has cooperated in working for better design procedures, construction guidelines, and specifications for all types of concrete overlays. Among the major advances has been the better definition of how the existing pavement should be evaluated and prepared for a concrete overlay. Another has to do with improved methods of placement of concrete overlays, improved design methodologies, and synthetic fiber technology. Fiber-reinforced concrete resurfacings have been on the increase because they contribute to the performance of thin concrete resurfacing. The improved performance comes from the increase in concrete structural integrity through improved toughness and durability of the concrete. Major research projects have been completed, providing long-term solutions of bonded and unbonded overlays of concrete and hot mix asphalt (HMA) pavements. These efforts, along with pricing factors and a national focus on training outreach and technical guidance development, have led to more acceptance

and increased use of high-quality concrete overlays.

Not surprisingly, concrete resurfacings share two design requirements with on-grade concrete pavements: they require uniform support conditions and management of movement if satisfactory performance is to be realized. Nearly all the documented cases of premature overlay failure can be traced to some violation of these requirements, often a result of incorrect assessment of the existing pavement. For this reason, the evaluation of the existing pavement is paramount to determine if uniform support and movement control of the underlying pavement and interface layer exist or can be cost-effectively made to exist. If so, will a bonded concrete overlay act as a monolithic unit with the underlying pavement and provide the structural capacity, load transfer, and drainage system required to meet the design life? If not, an unbonded overlay will be necessary to meet the same criteria but with a slightly different approach toward overlay thickness, drainage, and vertical constraints.

Concrete resurfacing can be either a preservation fix or a rehabilitation fix. With a preservation fix, the resurfacing is normally completed with a bonded overlay over existing pavement that is in good or fair condition or repaired or milled to bring it to that condition. The preservation fix represents the lowest possible cost with possible small amounts of localized failures (<1 percent) within the design life. For a rehabilitation fix, the resurfacing is normally completed with an unbonded overlay over poor or deteriorated materials. To have a successful overlay, not only should the good and poor characteristics of the existing pavement be understood, but the level of expected success for dollars expended must be realistic. The initial costs can be minimized, but a shorter performance and greater need for additional maintenance in the future is normally the result, or the initial costs can be greater with greater performance and reduced follow-up maintenance.

Minor cracking and localized failures should be expected when placing a concrete overlay on existing pavements. This should not be viewed as a lack of performance, but rather as a cost-effective treatment that may require some further maintenance. In many cases, it will be more cost effective to anticipate some maintenance costs for a concrete overlay rather than go overboard on preoverlay repair costs in an attempt to prevent any cracking or localized failures.



Figure 4. Forty-six states where concrete overlays have been constructed (shaded in blue)

Sustainability

Many agencies are emphasizing sustainability in their pavement management decisions. Quantifying the impact of pavement decisions on the primary sustainability factors of (1) environment, (2) society, and (3) economics is nearly impossible. We can, however, look at the sustainable benefits of concrete overlays from a qualitative perspective and conclude the following:

- Preserving the existing pavement has a minimal impact on the environment (no waste products are produced).
- User delays during construction are reduced as compared to reconstructing a pavement.
- Concrete overlays are capable of maintaining their smoothness for many years, which provides a benefit to society.
- Concrete overlays typically have a lower life-cycle cost than asphalt overlays of equivalent design life.

Concrete overlay pavement systems can be sustainable for a wide range of design life choices. Rather than removing and reconstructing the original pavement, the owner maintains and builds equity in it, realizing a return on its original investment as long as the original pavement remains part of the system.

For these and other reasons, concrete overlays are cost-effective, sustainable solutions. They

provide societal benefits in the form of reliable load-carrying capacity and fewer and shorter disruptions to traffic for pavement resurfacing and rehabilitation.

Asset Management through Resurfacing Solutions

Simply put, asset management involves a strategic and systematic approach to managing pavements; it relies heavily on pavement management data and life-cycle cost analysis. Pavement management and pavement preservation activities have become extremely important in managing and accounting for investments in highway pavements.

First, a little explanation to eliminate confusion. For the last half century, “pavement rehabilitation” has been defined as a functional or structural enhancement of a pavement, which produces a substantial extension in service life, by substantially improving pavement condition and ride quality. Over the last decade, the Federal Highway Administration (FHWA) has been a strong proponent and supporter of the concept of cost effectively preserving the country’s roadway network. This has helped in the recent years to spur a nationwide movement of “pavement preservation” and “asset management” programs.

A number of definitions for the terms rehabilitation and preservation have existed for years, and these terms are constantly misused or incorrectly used interchangeably. The following descriptions are promoted by FHWA.

Pavement preservation is a *strategy*, a network-level, long-term program to enhance pavement performance by using an integrated, cost-effective *set of practices* that extends pavement life, improves safety, and meets motorist expectations without reconstruction. Pavement rehabilitation is defined as a structural or functional enhancement of a pavement that produces a substantial extension in service life. To preserve a pavement, it must be maintained and at times rehabilitated. As shown in Figure 5, pavement preservation is considered preventive maintenance plus minor rehabilitation.

What is the difference between concrete resurfacing and concrete overlays? Resurfacing is a generic term for providing a new or fresh surface on the existing pavement and is considered mainly a preservation (preventive maintenance and minor rehabilitation) strategy. Concrete resurfacing consists of both bonded and unbonded concrete overlays. It is an integral component of a comprehensive asset management approach, because it cost effectively extends pavement life and improves both functional and structural characteristics. The variety, flexibility, and cost effectiveness of concrete resurfacing, using overlay options, make resurfacing an excellent solution for a

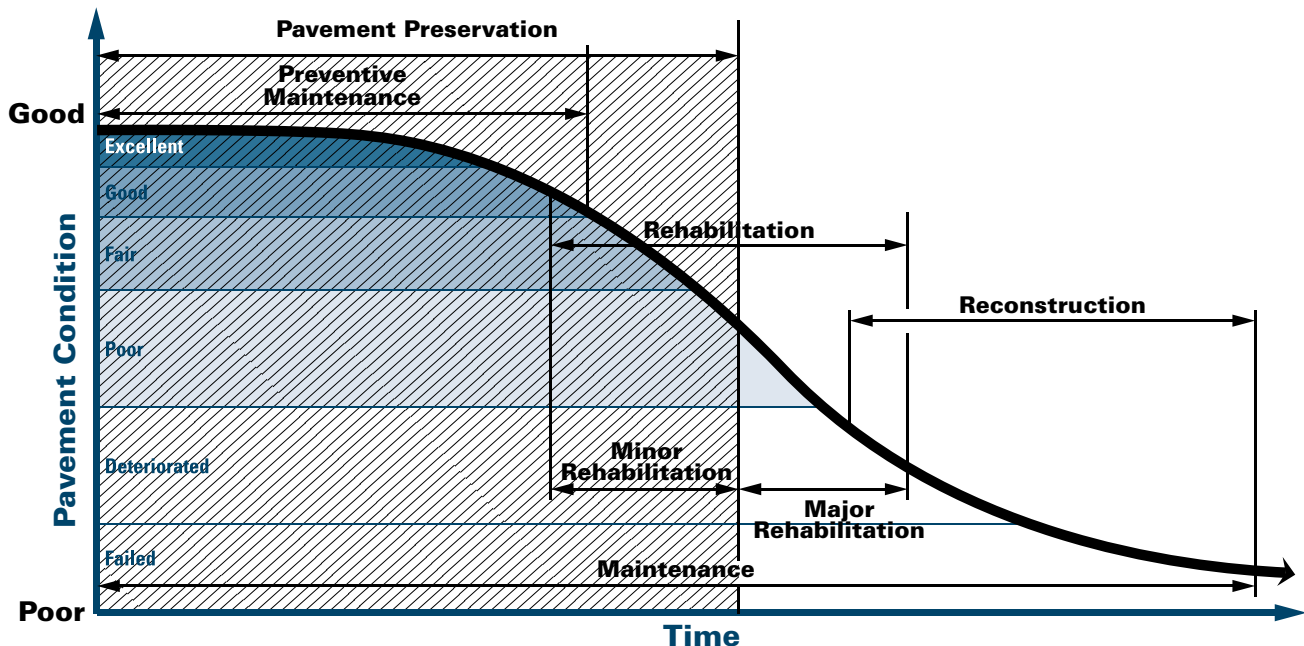

Figure 5. Appropriate preservation solutions at various stages of pavement service life

full spectrum of pavement needs. Figure 6 represents a typical pavement condition curve over the life of a pavement. The preventive maintenance, minor rehabilitation (together, the preservation window), and major rehabilitation zones are noted where bonded and unbonded overlays can be used to restore pavement to the original or better condition.

Preventive Maintenance

Preventive maintenance is a major component of pavement preservation. Basically, it consists of extending the service life of structurally sound pavements by applying cost-effective treatments to the surface or near the surface. Bonded concrete overlays of approximately 2 to 4 inches provide excellent preventive maintenance strategies for all types of pavements.

Minor Rehabilitation

Minor rehabilitation is used when structural capacity needs to be restored to a pavement but major rehabilitation is not required. One of the major advantages of concrete overlays as a preservation solution is that they increase the pavement’s structural capacity, even if that is not the primary objective of the preservation activity. Bonded and unbonded concrete overlays of 4 in. (102 mm) provide excellent minor rehabilitation solutions.

Major Rehabilitation

For pavements needing structural improvement, major rehabilitation is the approach typically used. Major rehabilitation calls for structural enhancements that extend the

service life of an existing pavement and/or improve its load-carrying capability. Bonded concrete overlays up to 6 to 7 inches are not uncommon, and unbonded overlays from 6 to 10 inches have been the norm.

To show the significance of concrete overlays as a rehabilitation strategy, the American Association of State Highway and Transportation Officials (AASHTO) (2007) recently stated that “thin unbonded concrete overlays, 4–5 in. [100–125 mm] in depth, have proven to be a rehabilitation option for composite (asphalt over concrete) pavements that exhibit significant deterioration. When properly designed and constructed, unbonded concrete overlays have been shown to increase load-carrying capacity and extend pavement life.”

Lessons Learned from Recent Concrete Overlay Projects

To ensure that concrete overlays provide durable, long-lasting maintenance and rehabilitation solutions, basic good design and construction practices must be followed. These include designing an overlay that is appropriate for the situation, accomplishing appropriate preoverlay repairs and preparation of the existing pavement, and using good construction practices like proper jointing and curing. With thorough planning, work zones can be managed to accommodate these activi-

ties without sacrificing project safety, traffic flow, or cost effectiveness.

Like its predecessors, this third edition of the *Guide to Concrete Overlays* is the result of collaboration between state departments of transportation (DOTs), industry, and academia to further enhance the state of the practice for the design and construction of concrete overlays. Many of the updates to this edition are a result of the Concrete Overlay Field Application Program conducted by Iowa State University’s National Concrete Pavement Technology Center (CP Tech Center) under a cooperative agreement with the FHWA. Through this program, expert teams visited 26 sites in 18 different states, and concrete overlay projects were either constructed or scheduled for construction in nine states. Many lessons were learned while assisting agencies with the design and construction of concrete overlays, which prompted the development of this updated edition. A summary of the key lessons learned is provided below:

Project Evaluation and Selection

Lessons learned regarding project evaluation and selection include the following:

- Utilize coring, falling weight deflectometers (FWDs), and “as built” plans to investigate existing pavement layer conditions and thicknesses to determine what type of overlay is appropriate for a given roadway.
- If existing asphalt will be milled, take cores of asphalt to ensure that adequate (mini-

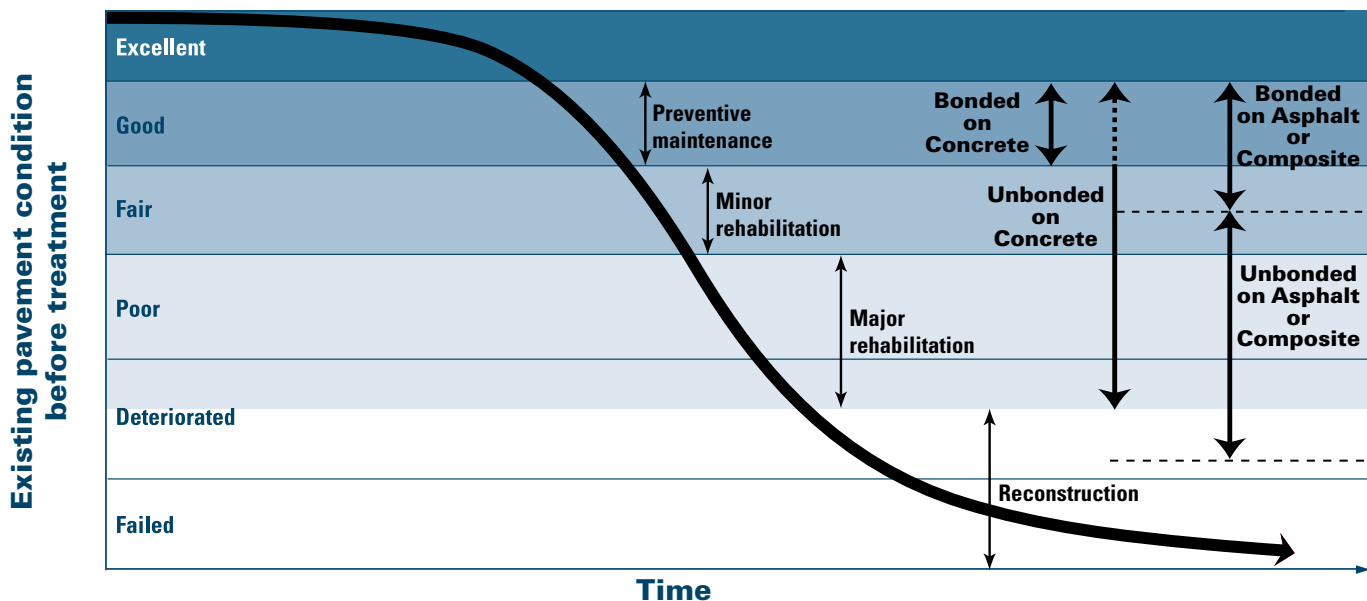

Figure 6. Typical bonded and unbonded concrete solutions at various stages of pavement service life

mum 3-inch) asphalt depth will remain after milling as a design minimum and to allow loaded concrete trucks to travel on the milled surface with minimal damage to it.

- In freeze-thaw climates and/or areas with expansive soils, evaluate existing pavement in spring and summer to identify critical pavement distresses that need to be accounted for in the overlay design.
- Identify all vertical constraints (bridges, utilities, loop vehicle detectors, curbs, barriers, ramps and driveways, guardrails, and other structures) that may impact construction and develop a plan to mitigate them.

Concrete Overlay Design

Lessons learned regarding design include the following:

- During the early phases of design, consider all partial and full detour options and their impact on construction.
- Choose the most appropriate overlay type (bonded or unbonded) to meet existing pavement conditions and anticipated future traffic loadings.
- For unbonded overlays over concrete in nonarid climates, provide a positive drainage path for surface moisture to exit the interlayer bond breaker (separation layer) to prevent interlayer erosion under heavy traffic loadings.
- In designs for unbonded overlays over concrete, compare asphalt or geotextile interlayer (separation layer) costs, construction time, and performance.
- Determine transition lengths from the existing profile elevation to the top of the concrete overlay profile elevation on existing profile constraints, final roadway design speeds, length and type of traffic control to be used, and final open-to-traffic speeds.
- Utilize cubic yard and square yard payment items. Square yard covers placement, and cubic yard covers material, which reduces contractor risk and cost while paying for concrete used to fill surface irregularities.
- Based on construction economics and expected overlay performance in designs for unbonded overlays over concrete, correct irregularities in cross slope and profile by varying the thickness of concrete, not the depth of the asphalt bond breaker (separator layer). Deeper transverse joint sawing may be necessary to achieve T/3, but final overlay performance will be enhanced.
- In designs for bonded overlays over asphalt, exercise care when milling the asphalt to prevent leaving a thin asphalt lift, which can cause delamination.
- Consider two potential overlay quantity design options:
 - For minimal preliminary work and cost
 - Do no preliminary surveys other than measuring wheel-rut depth and pavement cross slope at 500-foot intervals.
 - Develop design profiles of centerline and pavement edges.
 - Estimate the quantity of concrete required to meet the profiles and provide minimum thickness at centerline and edges of pavement.
 - Add a reasonable percentage to the concrete quantity to account for placement tolerance, construction losses, and surface/cross-section irregularities and establish the “new theoretical” plan quantity. Some states use 15 to 20 percent, depending on the thickness of the overlay and the amount of pavement cross-slope correction desired. The thinner the overlay and the higher the cross-slope correction, the higher the percentage. Some states add a maximum overrun of 2 to 3 percent to the “new theoretical” plan quantity.
 - For optimization of concrete quantities
 - Conduct nine-shot cross sections at 50-foot intervals to map the existing surface.
 - Develop a design centerline profile and cross slope that optimizes pavement smoothness, maintains minimum overlay depth at centerline, and optimizes concrete quantities.
 - Limit the contractor to an additional percent of the quantity identified by the desired cross section and design profile. Some states use 6 to 8 percent, depending on the thickness of the overlay.
- Evaluate the impacts of removing/replacing medians or existing curbs versus their retention in terms of construction time, cost, and future performance.
- Carefully review the construction sequence and maintenance of traffic in conjunction with joint layout. In some cases, tied longitudinal construction joints can interfere with the maintenance of both public and contractor traffic.
- Develop the construction sequence to meet closed-road or through-traffic maintenance in conjunction with joint layout and design for turn lanes and shoulder concrete work.
- Develop staging plans that allow for the use of paving equipment between existing concrete railings and temporary safety-related barrier walls.
- Design transitions and bridge-approach pavement sections to minimize hand placement and detailed jointing plans.
- Determine the type and amount of surface preparation required based on agency prioritization of the following goals:
 - Pavement smoothness
 - Concrete quantity
 - Matching existing surface features
 - Maintaining minimum cross slopes
 - Removing unstable existing pavement layers
 - Vertical clearance site conditions
 - Bond enhancement between existing and overlay pavement layers

Plans and Specifications

Lessons learned regarding plans and specifications include the following:

- Reduce plan sets to necessary quantities, design details, plan/profile data (not sheets), and survey control information.
- Require the use of vibrator frequency monitor recorders on the paver.
- Utilize standard concrete mixes and maturity measurements to control opening of intersections and access points. Use accelerated concrete mixtures only when necessary.
- When existing surface milling is required, clearly define the purpose, vertical and cross-slope limits, and required existing surface survey accuracy.

Sequence of Construction and Maintenance of Traffic

Lessons learned regarding construction sequencing and traffic maintenance include the following:

- Hold a public preconstruction meeting to communicate traffic control impacts and identify public concerns that should be addressed by the contractor and highway agency during construction.
- Minimize the number of gaps for intersections and driveways to provide for uninterrupted paving.

- Consider paving plans that allow temporary access for adjacent property owners where possible and accommodate their daily needs.
- Clearly state the criteria for lane closures and allow for contractor alternative suggestions to meet the criteria.
- Provide for alternative detour routes to be used in the case of unforeseen circumstances (crashes, wide loads, equipment breakdowns, etc.).
- Jointly with the contractor, develop a traffic control plan that allows sufficient room for construction operations and keeps the traveling public and pedestrians safe.
- Anticipate and mitigate temporary drainage issues caused by milling operations.
- In the case of construction of single-lane overlays with 24-hour pilot car operations on a two-lane road, apply the following construction suggestions:
 - Allow multiple construction zones separated by two miles between flagger stations. The 2-mile work zone area requirement is the distance between flagger stations versus the outermost warning signs.
 - Consider using a 3.5-mile paving work zone and allow the contractor to close local crossings in the work zone only when those in the adjacent zone are open.
 - Allow the contractor to propose methods and materials to construct temporary access ramps (in use for less than one month).
 - Encourage construction of bridge work, transition sections, subdrains, pavement patching, side ditch drainage work, and

earthwork prior to staged surface preparation and paving operations.

- Delete centerline safety wedge construction where pilot car operations are used 24/7 through the work area.
- Allow for equipment work on shoulders and side ditches to proceed in the same area as a lane closure employed for other prepaving work.
- Where bridge approaches and road intersections are immediately adjacent to each other, encourage use of extended temporary barrier-rail lengths and three-leg traffic signal setups to reduce construction/traffic delays.

Concrete Overlay Construction

Lessons learned regarding construction include the following:

- Require contractor development of a comprehensive paving plan to address construction and public impacts.
- When necessary, accelerate all construction processes to minimize public impact. Limit contract stage work times to emphasize the need for accelerated work if that is the goal of the contract.
- Where load transfer is called for in wheel paths only, use separate partial dowel baskets for each wheel path and do NOT cut the basket shipping wires.
- When anchoring dowel baskets, consider the use of uniform thicknesses of separation layer, adequate numbers of anchors, and the relationship of anchor length and shot force to the separation layer depth and material; minimize the head of concrete in

front of the paver. Monitor dowels behind the paver for location, orientation, and depth.

- Utilize software such as HIPERPAV to anticipate paving or curing problems and mitigate their impact on operations.
- Minimize the temperature differential between the existing pavement surface and the concrete overlay during placement and curing. This is especially critical during cool-weather paving for the following reasons:
 - When a bonded concrete overlay is placed in cooler weather, the day/night temperature differential will cause movement in the existing pavement; it will expand during the day and contract at night. To prevent cracking in the overlay, the overlay must reach saw strength before the underlying pavement's nighttime contraction. Specifying a minimum overlay mix temperature of 65°F has proven to be helpful in mitigating this set-time issue.
 - In addition, when a concrete overlay is placed in cooler weather, the concrete can set from the bottom up, delaying the sawing window. Temporarily covering the overlay with plastic after paving helps the concrete to set properly, allowing for timely sawing.

This guide provides updated guidance for the design, construction, and maintenance of concrete overlays, which should be adapted to fit local conditions and policies. Successful performance of any pavement rehabilitation method requires that design, materials, and construction be considered as complementary processes.

Chapter 2.

EVALUATING PAVEMENTS AND SELECTING SOLUTIONS

Evaluating the existing pavement condition is an important part of the pavement preservation and rehabilitation process. A comprehensive evaluation provides valuable information about the pavement's condition, performance capabilities, and limitations, including the following:

- Identification of all in-situ pavement layers
- Characteristics and behavior of in-place pavement materials
- Presence, type, and extent of distress
- Structural condition and load-carrying capacity
- Functional characteristics of the pavement, such as grades, roughness, friction, and noise

Several activities can be performed as part of the pavement evaluation process (see Hall

et al. 2001; Hoerner et al. 2001; NCHRP 2007). Specifics will vary from project to project, depending on the project type and relative significance. For the purpose of determining whether or not a concrete overlay is a good candidate for an overlay, the process can be divided into the following mandatory and optional steps. The steps for pavement evaluation are shown in Figures 7 and 8 on the following pages. Appendix A also provides evaluation tables based on existing pavement type and condition.

Mandatory evaluation activities include the following:

- Historical data collection, records review, and future projections (desk review)
- Visual examination (on-site review)
- Core analysis
- Pavement evaluation report

Optional evaluation activities include the following:

- Additional tests (including FWD, analyses of material-related distresses, drainage, roughness, and surface friction) if the cause of distress is unknown or if additional information is needed to determine the extent of distress
- Condition assessment profile

The evaluation concludes with a profile of the overall pavement condition assessment. See Figure 8.

After a pavement has been thoroughly evaluated, then a solution can be selected. In many cases, either a bonded or unbonded concrete overlay will be an appropriate and effective solution. For those pavements for which a concrete overlay is not appropriate, other treatment options are discussed in Appendix B.

Initial Evaluation (steps 1-4)

1 Pavement History and Performance Goals

- Pavement material (including aggregate CTE), design, age, thickness, layers
- Existing traffic and performance level
- Design life
- Remaining life
- Desired traffic and performance level
- Desired design life
- Elevations and grade restrictions
- Other historical information

2 Visual Examination

Concrete



Good

Asphalt / Composite



Good



Fair



Fair



Poor



Poor



Deteriorated



Deteriorated

3 Core Analysis

- Type of distress
- Depth of distress
- Verification of thickness for pavement base/subbase

4 Optional Analyses

(depending on extent of problems)

4-a. Material-related Tests

(indicated by core analysis)

Conduct if (a) material or durability issues are indicated, or (b) roadway provides service for high levels of traffic, especially if a bonded overlay is being considered.

- Petrography analysis
 - Concrete material-related distress (MRD)
 - Poor air-void system
- Asphalt stripping
- CTE

4-b. Subsurface Tests

Conduct if (a) pavement or subgrade support issues are indicated, or (b) roadway provides service for high levels of traffic, especially if a bonded overlay is being considered.

- FWD tests
 - Subgrade/subbase support (*k* value)
 - Subgrade/subbase variability
 - Pavement properties
 - Load transfer efficiency
 - Presence of voids
 - Asphalt stiffness
 - Concrete flexural strength
- Subgrade tests
 - Freeze-thaw characteristics
 - Shrink-swell characteristics
 - Soil strength (dynamic cone penetration or standard penetration test)

4-c. Surface Texture Tests

Conduct if (a) materials or durability issues are indicated, or (b) roadway provides service for high levels of traffic, especially if a bonded overlay is being considered.

Figure 7. Pavement evaluation process, with examples of existing pavement conditions (source: Snyder & Associates, Inc.)

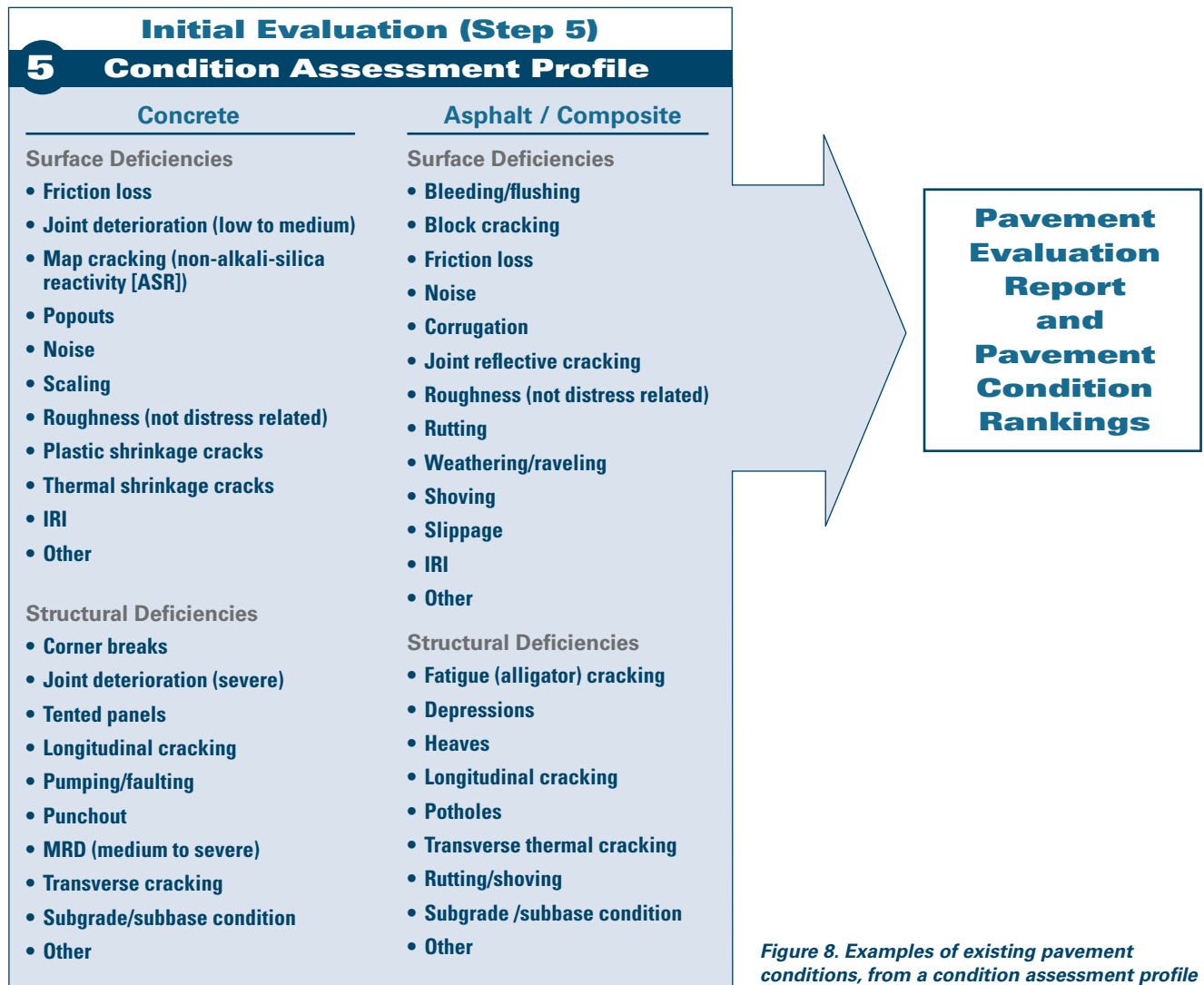

Figure 8. Examples of existing pavement conditions, from a condition assessment profile

Pavement Evaluation Process

The purpose of evaluating the existing pavement's condition is to collect details about any distresses and performance problems that currently exist and their causes. This information helps the owner-agency determine if a pavement is a good candidate for a concrete overlay and, if so, the extent of spot repairs required before an overlay is constructed. The extent of repairs needed is an important factor in determining if/when either a bonded or unbonded overlay will be a cost-effective solution.

Evaluating the existing pavement's condition involves at least three steps:

1. The first step is to review the pavement's historical design and performance record—pavement thickness and other design attributes, mixture materials and design, construction date and method, traffic loadings, design life, maintenance activities to date, etc.

Along with looking at the historical records, this step should include recording future performance requirements, such as expected traffic loadings and overlay design life.

This step should include a determination of any elevation limits and/or grade restrictions that signal potential clearance issues for overlay construction.

2. The second step is a visual examination of the pavement's condition, noting visible surface and structural distresses.
3. The third step is a more thorough examination of the pavement structure through a core analysis. This step will identify distresses or performance problems that cannot be determined by a visual exam alone. Core analyses verify pavement thickness, the subgrade/subbase material and thickness, and the depth and perhaps type or cause of distresses.

Based on information learned in steps 1 through 3 (Figure 7), the necessity for addi-

tional evaluation should be considered. For example, tests related to materials or durability distresses, possible support problems, or surface conditions may be necessary. The following questions can help the pavement owner determine if additional tests are advisable:

- What is the extent of pavement distresses, based on the visual evaluation and core analysis?
- What is the pavement's expected service level and life? Major highways with significantly high truck volumes and/or long service life require more extensive and comprehensive evaluations than lower-volume roadways.

Results from all initial evaluation steps should be recorded in a Condition Assessment Profile. This profile helps the agency determine the pavement's overall condition and summarize it in a Pavement Evaluation Report.

Historical Data and Future Projections (Desk Review)

The first step is to collect data from office files and other historical records associated with the project. The goal is to collect as much information about the existing pavement as possible, such as original design data, construction information, subgrade/subbase data, materials testing data, traffic data, performance data, and so on. Possible data sources for this effort include the following:

- Design reports
- Construction plans/specifications (new and rehabilitation)
- Materials and soils properties from previous laboratory test programs and/or published reports
- Past pavement condition surveys, non-destructive testing and/or destructive sampling investigations
- Maintenance/repair histories
- Traffic measurements/forecasts
- Environmental/climate studies
- Pavement management system reports

Discussions with local design and maintenance engineers may also be beneficial and should be included as participants in the on-site review process. The information gathered in this step can be used to divide the pavement into discrete sections with similar design and performance characteristics.

This step also includes determining future performance requirements, such as expected traffic loadings and overlay design life. Consideration should be made for potential future traffic generators (i.e., special events, future development along the route, etc.) that may impact the thickness design procedure.

Visual Examination (On-site Review)

With historical information in hand, the second step is a visual site inspection to obtain initial information about the pavement's performance and distress issues. Members of the design team should conduct the visual examination. At a minimum, the following items should be reviewed and recorded for future reference:

Existing Support and Localized Distress

One key to successful concrete overlays is ensuring that the underlying pavement and subgrade/subbase provide uniform support. Information gained from distress surveys will have the greatest impact on identifying necessary spot repairs and selecting appropriate overlays. Pavement distress in the form of visible defects or deterioration of the pavement is the most basic indication of an existing pavement's current performance and structural condition. The FHWA publication *Distress Identification Manual for the Long-Term Pavement Performance Program* (2003a) is useful when identifying pavement distresses and measuring their severity. Information obtained in this step will be used to determine the type and extent of field testing required.

Types of distress are determined primarily by occurrence and appearance and can indicate the underlying causes of deterioration. Severity of distress represents the criticality of the distress in terms of progression; more severe distresses will require more extreme rehabilitation measures. The extent of each distress type and severity level must be measured when an overlay is considered.

For example, consideration should be given to any deterioration of an asphalt surface course (existing asphalt or composite pavement), because asphalt is a good reflector of underlying problem areas. Examples include subbase/subgrade problems due to poor drainage, material-related distresses (MRDs) such as alkali-silica reaction (ASR) or D-cracking in a concrete layer, and other defects that result in isolated expansion or loss of support.

Panel tenting (early stages of blowups) may indicate the presence of a void under a concrete panel in an existing concrete or composite pavement. Sections with significant tenting can be repaired to relieve the pressure and provide uniform support. If, during the desk review process, an open graded base (OGB) is found to be part of the pavement structure, an FWD analysis is warranted (see Optional Analyses on page 15) because of the likelihood of secondary consolidation of the OGB, which results in nonuniform support conditions. This FWD testing should be done prior to the on-site review to assure that the design team has the information at hand to assist in evaluating the support conditions.

Drainage Surveys

Poor drainage conditions are a major cause of distress in pavement structures. Unless moisture-related problems are identified and corrected, the effectiveness of repairs and overlays will be reduced. As part of a pavement distress survey, the overall drainage conditions of the existing pavement should be assessed. Excavation at the edge of the pavement may provide useful information regarding trapped water and other drainage issues. Observations of moisture/drainage problems (e.g., pumping, corner breaks, standing water, etc.) may indicate the need for a more intensive FWD test for the support value k or a more thorough survey of subsurface drainage conditions. The purposes of a drainage survey are the following:

- Detect and identify moisture-related distress
- Document prevailing drainage conditions (e.g., cross slopes, cut/fill areas, depth and condition of ditches)
- Assess edge-drain conditions

If edge drains are present, their effectiveness should be evaluated by observing their outflow after a rainfall or after water is released from a water truck over pavement discontinuities. Another way to assess edge-drain effectiveness is through video inspections (Daleiden 1998; Christopher 2000). A video camera attached to a pushrod cable and inserted into the drainage system at outlets can locate blockages like rodents' nests or areas of crushed pipe. Several states have adopted edge-drain video inspection in their pavement evaluation/construction process. The visual examination should include the location and inspection of all under-drain outlets.

It is especially important to determine the subgrade soil's freeze-thaw and shrink-swell characteristics. Soil strength-related tests using the dynamic cone penetrometer or the standard penetration test provide useful information about subgrade stability.

Possible drainage problems indicated by a drainage survey may suggest the need for in-depth analysis of the pavement structure's drainability. DRIP (Drainage Requirements In Pavements), an FHWA computer program, can assist in such an analysis (Mallela et al. 2002).

Material-related Distress (MRD) in Existing Concrete Layer

Pavements exhibiting MRD may be viable candidates for unbonded concrete overlays, but when MRD is suspected or known to exist, the extent of present and potential future distress must be assessed. In many cases MRD manifests as bottom-up deterioration, which means that visible distresses may be minimal to moderate while distresses at the bottom of the pavement are severe. A quick and inexpensive method for checking for bottom-up deterioration is to excavate at the edge of the pavement at multiple joint locations and visually inspect for deterioration that is not visible from the surface; see Figure 9. In all cases where MRD is suspected, however, laboratory testing as referenced above is needed to assess the degree of deterioration as well as the potential for future deterioration.

When a concrete overlay of an MRD pavement is deemed viable, the design life of the overlay should take into account the remaining life of the existing pavement. The lower the severity and rate of the MRD, the higher the chance of longer service life.

Bonded concrete overlays over pavements with MRD are not recommended due to the movement of the pavement from the MRD and subsequent reactive cracking. However, unbonded concrete overlays have been constructed on pavements with MRD for years. A good example is the 5-inch unbonded overlay of a concrete pavement with D-cracking in the Kansas City metro area on Route D35 (see Figures 44 and 45 in Chapter 3). After seven years carrying more than 9,000 vehicles per day, the overlay is in excellent condition. There is little, if any, information or research documenting the condition of existing pavements with MRD before concrete overlay construction or the performance of unbonded concrete overlays on pavements with MRD.

The three most common mechanisms that cause MRD in concrete are alkali-silica reaction, D-cracking, and freezing and thawing; these mechanisms and their influence on overlay performance are described below. In principal, any continued expansion due to the mechanisms discussed below will likely shorten the life of an overlay.

Alkali-silica Reaction (ASR)

Alkali-silica reaction is a reaction that occurs over time between water, alkali-hydroxides in cement paste, and reactive noncrystalline silica found in some aggregates (see Figure 9). This reaction creates an alkali-silicate gel that absorbs water and expands, exerting expansive pressure inside the mixture and causing cracking and loss of strength of the concrete.

Alkali-silica reaction requires the presence of three ingredients: reactive aggregates,

FAQ—Can a pavement with MRD be an appropriate candidate for a concrete overlay?

Existing pavements that exhibit MRD should not be considered for a bonded overlay. They are, however, potentially viable as unbonded overlay candidates. Nonuniform support and loss of support are the primary issues to consider when designing an unbonded overlay of a pavement with MRD. Because MRD requires moisture to develop, further progression can sometimes be slowed through improved drainage of the existing pavement by retrofitting pavement edge drains prior to constructing a concrete overlay.

alkali hydroxides in the paste, and moisture. Expansion rates may vary, causing distress in years to decades depending largely on the mineralogy of the aggregates; see Figure 10. Absence of any one of the three ingredients will prevent the reaction, but in practice this may not always be possible.

Reducing the amount of water penetrating the concrete will slow the reaction, but the reaction will proceed if the relative humidity in the pores is greater than approximately 80 percent, which is almost always likely in pavements—even in arid climates. Once cracking begins in a concrete layer, it is likely that distress will accelerate because additional water can penetrate more easily.

Unless it can be demonstrated that all the alkalis have been consumed in the existing pavement, limiting future reactions, it should be assumed that the existing system will continue to expand. Suspect concrete must be evaluated to assess the potential for future expansion using approaches such as described in *Report on the Diagnosis, Prognosis, and Mitigation of Alkali-Silica Reaction (ASR) in Transportation Structures* (Fournier et al. 2010). The reduction of subsurface water, even in slow-acting ASR, is an important step in the effort to mitigate the ASR damage before replacing the riding surface an unbonded concrete overlay.

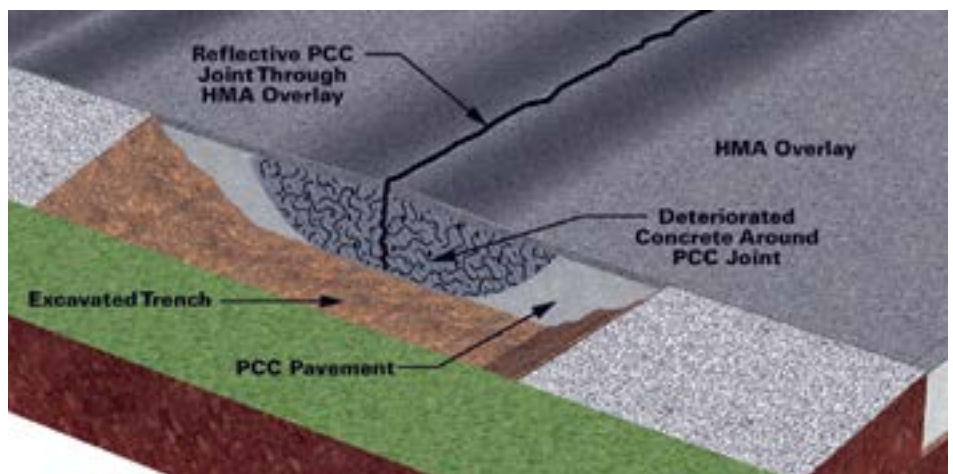

Figure 9. Visual inspection for MRD deterioration at the edge of pavement



Figure 10. Moderate ASR cracking along the perimeter of slabs (source: [Thomas et al. 2011])

D-cracking

D-cracking is damage incurred by the propensity for some limestone aggregates to absorb water when wet, but not release it under drying conditions because of the small size of the pores in the aggregate. The particles thus become saturated and, under freezing conditions, will crack and expand, causing damage in the mixture. The distress tends to begin at the bottom of a slab and at joints, and it progresses inward; see Figure 11.

In extreme cases, all that will be left is rubble. Evaluation of the risk varies from state to state, and reference should be made to local DOT knowledge of whether or not an existing layer is at risk. Typically, a D-cracking pavement will need repair in approximately 10 years, although some pavements have lasted as long as 40 years. If damage has already started, then it is likely to continue, causing damage zones at the joints to grow wider over time, therefore reducing support for any layer placed above it. Removing and replacing damaged sections may buy some time, but the distress will continue to grow in the at-risk concrete at the interfaces with the repairs.

As with any MRD, the likely remaining life of the damaged pavement must be accounted for when considering the design life of a concrete overlay.

Freezing and Thawing

Concrete that is saturated and subjected to freezing and thawing cycles will exhibit damage, particularly at the joints. This is largely due to the expansion of water within the system as it freezes and the lack of a proper air-void system (spacing and volume of air). Typically with a poor air-void system, the deterioration occurs at the joints where moisture is most prevalent; see Figure 12. The damage may continue to progress inward from the joint as moisture finds its way through the damaged zone.



Figure 11. D-cracked pavement

Any mitigation strategy that reduces access of moisture will slow or prevent continued distress. While an overlay may provide some degree of insulation, thus reducing the number of freeze-thaw cycles and slowing damage rates, the problem will not be eliminated. For a potential bonded overlay in which the existing pavement is to be brought to good condition by spot repairs or milling, it is important before selecting an overlay to periodically check the air content of the existing pavement in accordance with ASTM C 457. This check should be made at different depths of the mid-panels of the existing pavement as part of the evaluation process. For example, if the air content is below 5 percent and the spacing factor is greater than 0.008 inch, the details of moisture access have to be examined carefully before a bonded overlay is considered. This is particularly true if this condition exists in the lower depths.

For unbonded overlays, where partial- or full-depth deterioration of the joint is present, the unsound concrete around the joints can be removed and replaced with low-strength concrete (e.g., flowable mortar). No sawing or reestablishment of the joint is necessary, since the overlay will be unbonded and cracking in the existing concrete will not affect the overlay. This approach with an unbonded overlay should be a practical and cost-effective solution for pavements with freeze-thaw damage in poor or deteriorated condition. The desired project life of the overlay must match the expected life of the existing pavement after repairs are made.

Vertical Constraints

Constructing concrete overlays will raise the roadway profile grade unless it is lowered through mechanical measures such as milling.

Consideration should be given to the effects of grade change, particularly at bridge underpasses and approaches, shoulder areas, and curb and gutter units. Design details for these situations are included on pages 64, 69, and 70. The visual survey should include a comprehensive list of potential vertical constraints such as the following:

- Bridge structures
- Overhead clearance requirements
- Guard rail, parapet wall, cable barrier, and median barrier
- Curb and gutter
- Storm sewer inlets
- Intersecting roadways and access drives
- Drainage conduits and culverts
- Foreshoulder slopes and ditches

Profile Grade

A review of the existing profile grade line should be conducted; areas of significant deviation will have to be investigated through analysis of core samples. Evidence of numerous active panel movements in a concrete or composite pavement may indicate potentially unstable or nonuniform subgrade support or MRD. These, too, will require detailed pavement analyses to determine the extent of distress and possible corrective action(s). For example, if movement is confined to isolated areas, full-depth repairs in these areas may be considered. Irregularities in profile (significant dips/bumps) should be noted and the cause(s) should be determined. Typical cross slope of the existing pavement and the limits of superelevated curves should be included in the visual survey.



Figure 12. Typical joint deterioration with HMA patch (source: Trinity Construction Management Services, Inc.)

Pavement Coring

It may be difficult to determine the cause(s) and the extent of the cracking from a visual inspection alone. Core analyses can supplement information collected from the visual inspection. This can be done concurrently with the on-site review or at a later date. Core frequency and location should be determined based on the distresses noted during the visual examination.

At a minimum, two cores per lane per mile should be obtained to evaluate layer thicknesses and pavement condition. Whenever possible, members of the design team should be present during the coring to observe the condition of the pavement layers as they are cored.

Cores are beneficial in determining layer thicknesses and identifying the pavement's support value; the type and condition of layer materials; the depth of distress(es); and, if the existing pavement is full-depth asphalt or composite, the condition of the existing bond between layers. For asphalt and composite pavements, it is critical to evaluate the bond between lifts and identify stripped layers to determine whether or not the remaining asphalt (after milling, if any occurs) will be suitable for the concrete overlay design assumptions. Cores that penetrate into the subgrade may show evidence of unstable conditions, such as the beginning of fine soil migration into open-graded subbase layers that can lead to plugging and instability. Cores also provide samples for possible laboratory analyses.

Optional Analyses

Various factors affect the necessity for and extent of additional pavement evaluation tests. Additional testing may be necessary

FAQ—When are additional analyses really necessary?

In general, additional analysis (testing) to refine design inputs is only necessary when the existing pavement is in poor condition and/or heavy traffic is anticipated.

based on observations noted during the on-site review and/or analysis of pavement cores; see Table 1. Roadway type (i.e., primary or secondary) and reliability of the ensuing design may drive the decision. For example, a concrete overlay of a county road with moderate traffic could be designed with the information obtained in the first three steps. Conversely, a divided highway with heavy traffic may require additional information to more precisely characterize the existing pavement's properties.

A thorough pavement condition analysis is always necessary to assess the applicability of either a bonded or an unbonded concrete overlay solution. In general, more information about the existing pavement condition is required when bonded overlay systems are being considered or designed. There are several reasons for this:

1. Compared to an unbonded overlay, the performance of bonded concrete overlays is more dependent on the condition of the existing pavement
2. Because bonded overlays are relatively thin, they are somewhat more susceptible to stresses, and the very nature of a bond imposes stress.
3. The existing pavement will become part of a monolithic, overlaid pavement structure (not just a base for an unbonded overlay), so it needs to contribute a certain level of strength and integrity and be capable of developing and maintaining a bond with the overlay.

Therefore, when evaluating a pavement's suitability for a bonded concrete overlay, it is particularly important to characterize the existing cross section and pavement characteristics and the type, severity, and extent of distresses. Laboratory testing may not be required on every project. Lab tests may be conducted to confirm or clarify results from the visual examination, reveal distress mechanisms, and provide additional information needed to identify feasible treatments (see pages 18–23).

A detailed engineering evaluation of the type, degree, and state of MRD may be warranted to determine if an overlay is feasible. Unbonded overlays on concrete or composite pavements with MRD can be expected to have a long life, equal to a full-depth concrete pavement, if the overlays are designed correctly, taking into account any nonuniformity in the existing pavement. For this to be possible, the rate of MRD progression and the potential for further deterioration (post concrete overlay) needs to be understood.

Thicker unbonded overlays (6 in. [150 mm] or greater) have been used successfully on ASR distressed concrete pavement (alone or as part of an existing composite pavement) in a variety of climates and for a wide range of highway classes. These overlays perform extraordinarily well when the reactive aggregate expansion is near completion, has slowed its rate of deterioration, or is relatively uniformly spread throughout the existing pavement. Extreme variation in the degree of ASR distress along the length of pavement

Table 1. Recommended Optional Testing

Optional Testing	Existing Asphalt Pavement		Existing Composite Pavement		Existing Concrete Pavement	
	Bonded	Unbonded	Bonded	Unbonded	Bonded	Unbonded
Falling Weight Deflectometer (FWD)						
Modulus of Elasticity (E) of Asphalt	X		X			
Effective Static Modulus of Subgrade Reaction (k)	X	X	X	X	X	X
Load Transfer Efficiency			X	X	X	X
Cores						
Stripping (ASTM D 4867) of Asphalt	X	X	X	X		
Pavement Layer Thickness	X	X	X	X	X	X
Petrographic Examination			X _{1,2}	X ₂	X _{1,3}	X ₂

1 - Entrained air properties when low air content is the suspected cause of observed distress
 2 - Identify whether detrimental MRD is present
 3 - Determine aggregate type

FAQ—Why is optional testing for unbonded overlays necessary when the existing pavement is characterized as a “high-quality” subbase in the thickness design process?

Even though unbonded overlays are less dependent on the condition of the existing pavement than bonded overlays, there may be circumstances where additional optional testing is desirable. This is especially the case both for high-volume roadways where design reliability is critical and for any time that MRD is suspected in the existing pavement.

(particularly when distress is concentrated at the joints), however, can result in nonuniform support and consequent performance challenges for the overlay.

Since D-cracking normally occurs at or near concrete joints, bonded concrete overlays on concrete pavements with D-cracking (or composite pavements in which the concrete layer has D-cracking) have had mixed performance results. Localized joint movement and even failure can occur in the underlying pavement. This may cause cracking in the overlay as a result of the nonuniform base support.

Deflection Testing

Pavement deflection testing is an effective way to assess a pavement’s structural capabilities. The data can be used to estimate, through back-calculation methods, modulus of elasticity and k -value. Again, pavement deflection tests are not required for all pavements, especially those in fair or better condition or on lower-volume roads. When performed, a minimum of one test per lane per one-half mile should be conducted.

Several deflection devices are available, but they all operate in basically the same manner. A known load is applied to a pavement surface, and the resulting deflection is measured. The FWD, or any device capable of applying loads similar in magnitude and duration to that of a moving wheel load, is commonly used. Deflection test results are also used to develop pavement deflection profiles, back-calculate layer properties, determine load transfer capabilities, and evaluate the potential for voids at slab corners.

Alternative Means of Determining Support Conditions

In some cases, a visual examination and core analyses provide enough information to determine if the pavement is a good candidate for a concrete overlay. Sometimes, however, particularly in borderline situations, further analysis is required. One such analysis may include determination of the subgrade/subbase support conditions under the pavement in terms of the California bearing ratio (CBR).

A low-cost and easy on-site method for determining the level of support in terms of CBR is through the use of the dynamic cone penetrometer (DCP); see Figure 13. This instrument provides a measure of the in situ strength of fine-grained and granular subgrades and granular base and subbase materials.

A 17.6-lb (8-kg) weight is raised to a height of 22.6 in. (575 mm) and then dropped, driving the cone into the soil or other material being tested. The output is a penetration rate (PR) expressed in terms of inches (mm) per blow. (The DCP test method is defined under ASTM D 6351: *Standard Test Method for Use of the Dynamic Cone Penetrometer in Shallow Pavement Applications*.)



Figure 13. Dynamic cone penetrometer (source: David White, Iowa State University)

Soil strength-related tests using the DCP, or the standard penetration test, provide useful information about subgrade stability.

The benefits of the DCP test include the following:

- Low cost
- Easy to use—an operator can be trained in minutes
- Large penetration depth—data can be collected up to 36 inches in depth
- Fast—a large amount of data can be collected and the values converted to CBR quickly

Although the DCP does not measure density directly, it may be used to assess the density of a fairly uniform material by relating density to PR. In this way, under-compacted or “soft” spots can be identified.

The CBR value can also be important in terms of overlay thickness design. Concrete overlay design methods for determining overlay thickness use bearing capacity expressed in terms of the modulus of subgrade reaction (k). Although the k -value is difficult to measure, it can be estimated relatively easily from the CBR value.

Table 2. Subgrade Soil Types and Approximate Support Values

Soil Type	Support	<i>k</i> (psi/in.)	CBR
Fine grained; silt and clay-size particles predominate	Low	75 to 120	2.5 to 3.5
Sand and sand-gravel mixture with moderate amounts of silt and clay	Medium	130 to 170	4.5 to 7.5
Sand and sand-gravel mixture relatively free of plastic fines	High	180 to 220	8.5 to 12.0

Notes: CBR (California bearing ratio); 1 psi = 0.0069 megapascal (MPa); 1 psi/in.=0.27 MPa/m

Table is based on information in ACI 330R-08 regarding ranges of values for several types of subgrade soil (Portland Cement Association 1984; NCHRP 1982) compacted to the specified density.

In Table 2, above, CBR values are associated with *k*-values expressed in pounds per square inch (psi) per inch or pounds per cubic inch. In the table, both values are generally associated with subgrade soil types and support conditions. For projects designed for light-traffic loads only, or where extensive soil testing is impractical or economically unjustified considering the project scope, the *k*-value can be estimated. Conservatism is advised in making such estimates.

Roughness and Surface Friction Tests

Roughness and surface friction are two key indicators of the functional performance of a pavement: its smoothness for comfortable ride and its skid resistance for safety. Roughness testing (expressed in terms of the International Roughness Index, IRI) at the project level can be useful to help identify localized areas of roughness and to assess the effectiveness of treatments (pre- and post-treatment roughness comparisons). Friction (skid resistance) testing is not commonly conducted for project-level evaluations but may be meaningful on projects exhibiting a disproportionate number of wet-weather crashes.

Condition Assessment Profile

When all aspects of an existing pavement have been evaluated, the critical distresses and drainage conditions should be summarized. One useful way to summarize this information is to plot it on a condition assessment profile, or strip chart (Smith et al. 2008). In bar chart form, this profile visually indicates where various distresses occur over the length of the project, as well as their extent and severity. Distresses such as slab cracking, corner breaks, faulting and spalling, and continuous roughness can be displayed. Areas of poor drainage or significant changes in topography (cut/fill sections) can be overlaid on the strip charts. Such summaries provide critical insight into a pavement's structural and functional performance, helping roadway owners determine if and when pavement preservation or rehabilitation activities are appropriate.

Figures 14, 15, and 16 provide a graphical example of the pavement and evaluation and overlay selection processes.

Pavement Evaluation Report

The final evaluation step is summarizing the results of data collection and analyses in an evaluation report. Any critical nonpavement factors, such as shoulder condition, ditches, right-of-way, curves, bridges, ramps, and traffic patterns, should be identified in the report. Ultimately, this information will be used in the identification and selection of appropriate spot repairs and overlays, as described in the next section.

Selecting Appropriate Concrete Overlay Solution

Several factors should be considered when selecting the type of concrete overlay solution. The condition of the existing pavement is the paramount factor. Generally, existing pavements in relatively good condition, or that can be cost effectively brought to good condition, are candidates for bonded concrete overlays. In these cases, bonded overlays can improve functionality (e.g., reduce roughness or noise or enhance friction) and/or increase structural capacity (e.g., accommodate anticipated increases in truck-traffic loadings).

For example, a pavement in fair to poor functional condition due to rutting and shoving can be resurfaced with a bonded overlay after the pavement has been improved to good condition through spot repairs or milling to remove deficiencies. The bond between the overlay and the existing pavement inherently adds structural capacity. In this situation, however, it may be just as cost effective to place a slightly thicker unbonded overlay with less preoverlay repair work and not have to depend on the bond.

Generally, existing pavements in poor condition that exhibit significant structural deterioration are candidates for unbonded overlays. Moreover, the presence of MRD, such as alkali-silica reaction ASR or D-cracking, also suggests the need for an unbonded overlay or even reconstruction. See Appendix B for reconstruction options.

Concrete overlays can provide economical short- and long-term solutions for pavements in a variety of conditions, as shown in Figures 14–16 on the following pages. Note that the overlay solutions recommended in these flowcharts are generally long-term fixes, on the order of 20 years or more of expected life.

Selecting the Appropriate Concrete Overlay Solution for Asphalt Pavements

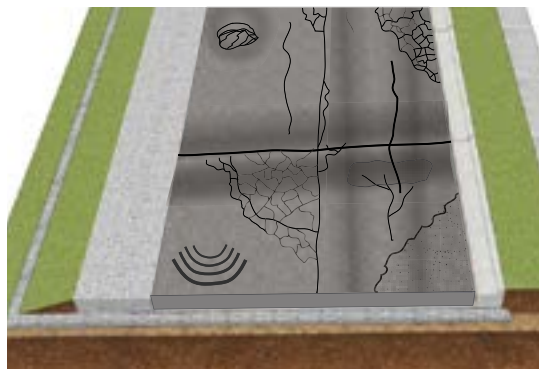
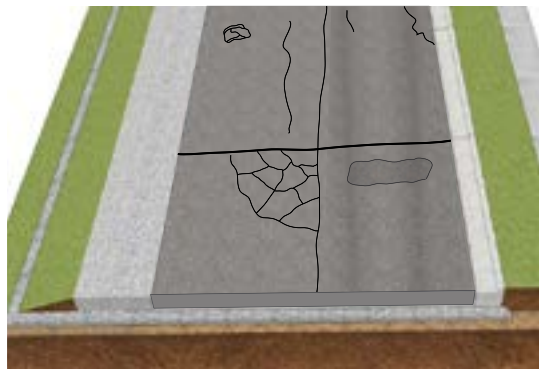
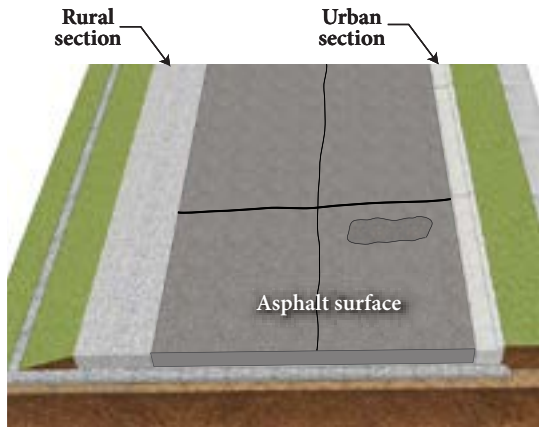

Concrete overlays can provide economical short- to long-term solutions for asphalt pavements. The recommendations provided in the following flowchart are generally long-term fixes on the order of 20 years or more of expected life.

As with any preservation approach, the principles of asset management are a cornerstone in selecting the appropriate concrete overlay solution. Three important asset management questions need to be answered as part of the selection process, for the appropriate concrete overlay solution to meet the needs of an agency. First, what is the desired level of service to be provided by the concrete overlay?

Good Condition

Pavement is structurally sound but needs increased structural capacity, improved surface characteristics (smoothness, friction, and noise), surface defects removed, and/or improved albedo properties.

Spot Repairs

Can spot surface repairs and/or spot structural repairs cost effectively solve deficiencies, bring the pavement to “Good Condition,” and meet other constraints (i.e., vertical clearances, shoulders, safety rails, foreslopes, etc.) to allow for a bonded overlay?

YES

Fair Condition

Pavement is structurally sound but has minor surface distresses such as potholes, block cracking, or random thermal cracking. Check for undulating profile grade to determine if sub-drainage issues exist. Check cores to ensure there is no measurable stripping or delamination in the asphalt.

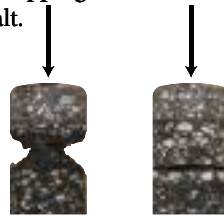

NO

Milling/Minor Spot Repairs

Can milling and minor spot repairs cost effectively solve deficiencies, bring the pavement to “Good Condition,” and meet other constraints (i.e., vertical clearance, shoulders, safety rails, foreslopes, etc.) to allow for bonded overlay?

YES

NO

Milling and Patching

Can spot structural repairs and/or milling cost effectively solve deficiencies, meet vertical and structural requirements, and bring the existing pavement to a condition that provides a uniform subbase for an unbonded overlay?

YES

NO

Additional Repairs

Can existing or potential unstable conditions or major deficiencies (e.g., wet subgrade, asphalt stripping) be addressed cost effectively with a combination of preservation techniques (e.g., milling, retrofit subdrains, full-depth patches) and other constraints (e.g., vertical clearance, safety rails, etc.) met with an adequately thick unbonded overlay?

YES

NO

Poor Condition

Pavement has measurable distresses beyond those described under “Fair Condition,” such as alligator cracking, rutting, shoving, slippage, stripping, and raveling.

Note: Asphalt is a good reflector of underlying distresses such as poor subbase conditions.

Deteriorated Condition

Pavement exhibits “Poor Condition” characteristics as well as significant deterioration, raveling, thermal expansion, stripping, and structural distresses.

Figure 14. Selecting appropriate concrete overlay solution for asphalt pavements

Second, what is the desired pavement life of the overlay, given the condition of the existing pavement? Third, what type of overlay (bonded or unbonded) will achieve the first two objectives at the lowest life-cycle cost?

Several factors should be considered when selecting either a bonded or unbonded concrete overlay for an existing asphalt pavement. Two predominant factors are the condition of the existing pavement and the extent of pre-overlay repairs required, if any.

Generally, existing pavements in relatively good or fair condition, or poor-condition pavements that can be cost-effectively brought to good condition, are candidates for bonded concrete overlays. Existing asphalt pavements that cannot be cost effectively returned to good condition are candidates for unbonded overlays as long as significant structural repairs to the existing pavements are not needed. Significant asphalt deterioration can be overlaid with concrete as long as unstable and soft spots are repaired. Unless there are unreparable subsurface issues requiring removal of the asphalt, it is rare that a unbonded concrete overlay cannot be utilized.

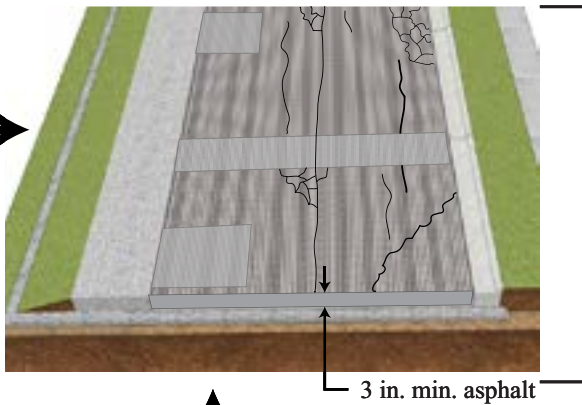
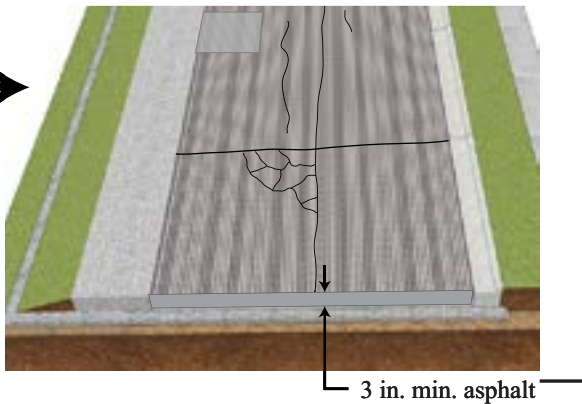
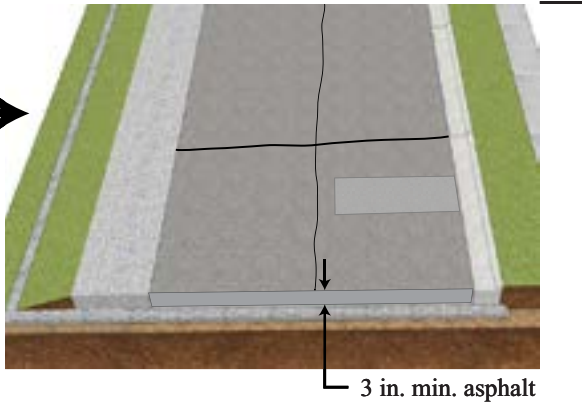

Bonded Concrete Overlay Over Asphalt Pavement

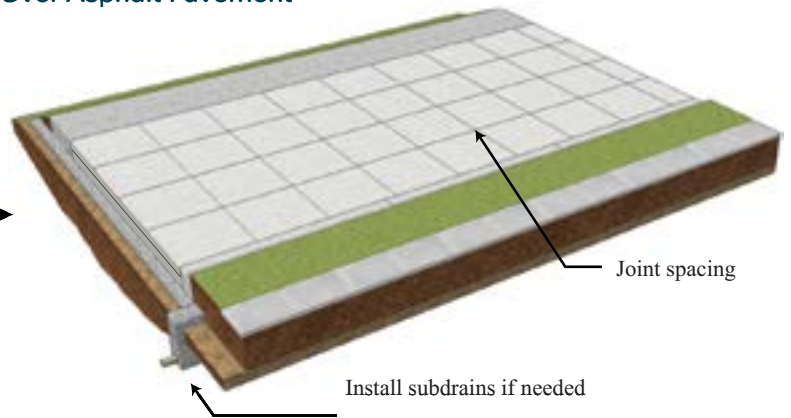

Note: Concrete overlay thickness must be appropriately designed considering estimated traffic, desired design life, and budget.

Unbonded Concrete Overlay Over Asphalt Pavement

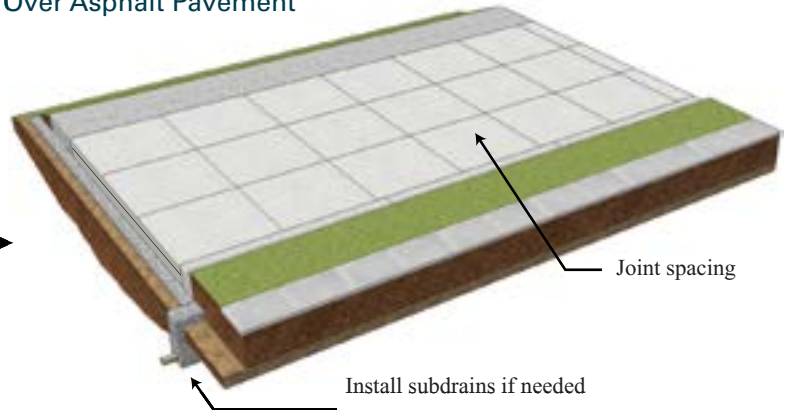

FAQ—What if the existing pavement is not a candidate for a concrete unbonded overlay? While most pavements can be preserved with a concrete overlay, there are situations where a concrete overlay is not appropriate. When this occurs, reconstruction is an alternative. Reconstruction options include the following:

- **Recommended:** Mill and fill. Remove asphalt by milling, repair any subgrade issues, and fill with new concrete pavement. Recycle asphalt material.
- **Permissible** in specific situations: When the asphalt is less than 6-in. thick and is in deteriorated condition, the asphalt may be recycled into the subgrade/subbase through full-depth reclamation (FDR).

Selecting the Appropriate Concrete Overlay Solution for Composite Pavements (Asphalt Over Concrete)

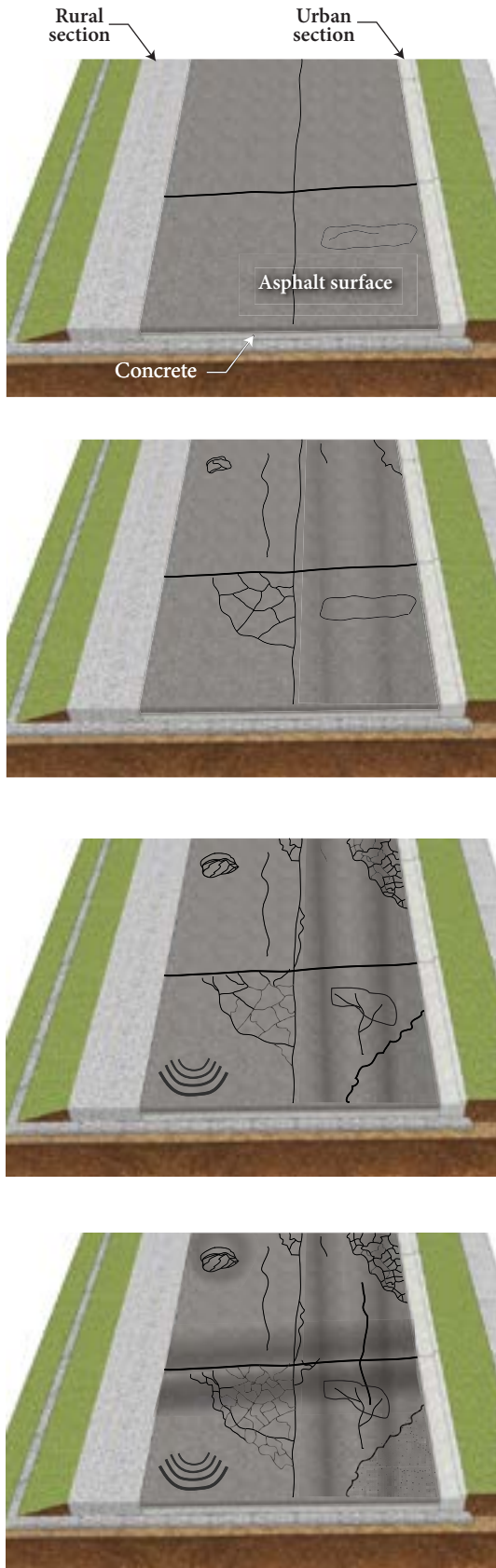

Concrete overlays can provide economical short- to long-term solutions for composite pavements. The recommendations provided in the following flowchart are generally long-term fixes on the order of 20 years or more of expected life.

As with any preservation approach, the principles of asset management

are a cornerstone in selecting the appropriate concrete overlay solution. Three important asset management questions need to be answered as part of the selection process. First, what is the desired level of service to be provided by the concrete overlay? Second, what is the desired pavement life of the overlay given the condition of the existing pavement? Third, what type of overlay (bonded or

Good Condition

Pavement is structurally sound but needs increased structural capacity, improved surface characteristics (smoothness, friction and noise), corrected surface defects, and/or improved albedo properties.

Spot Repairs

Can spot surface repairs and/or spot structural repairs cost effectively solve deficiencies, bring the pavement to “Good Condition,” and meet other constraints (i.e., vertical clearance, shoulders, safety rails, foreslopes, etc.) to allow for a bonded overlay?

YES

Fair Condition

Pavement is structurally sound but has minor surface distresses such as potholes, block cracking, random cracking, and thermal cracking. Check for undulating profile grade to determine if sub-drainage or secondary consolidation issues exist. Check cores to ensure there is no measurable asphalt stripping or delamination.

NO ↓

Milling/Minor Spot Repairs

Can milling and minor spot repairs cost effectively solve deficiencies, bring the pavement to “Good Condition,” and meet other constraints (i.e., vertical clearance, shoulders, safety rails, foreslopes, etc.) to allow for a bonded overlay?

YES

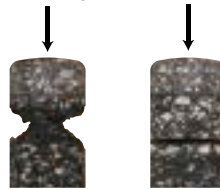

NO ↓

Milling and Patching

Can spot structural repairs and/or milling (asphalt layers prone to stripping to be removed) cost effectively solve deficiencies, meet other constraints (i.e., vertical clearance, shoulders, safety rails, foreslopes, etc.), and bring the existing pavement to a condition that will provide uniform subbase for an unbonded overlay?

YES

Poor Condition

Pavement has measurable distresses beyond those described under “Fair Condition.” These include alligator cracking, rutting, shoving, slippage, stripping, raveling, and possible MRD (see page 13).

NO ↓

Additional Repairs

Can existing or potential unstable conditions or major deficiencies (e.g., wet subgrade, MRD, faulting) be addressed cost effectively with a combination of preservation techniques (e.g., milling, retrofit subdrains, full-depth non-sawed lean concrete patches)? Can other constraints (e.g., vertical clearance, safety rails, etc.) be met with an adequately thick unbonded overlay? Does the asphalt need to be completely milled to remove major deficiencies such as stripping and a new interlayer placed between the underlying concrete and a new unbonded overlay?

Note: Asphalt is a good reflector of underlying distresses such as a poor subbase or joint deterioration in concrete pavements.

Deteriorated Condition

Exhibits “Poor Condition” as well as significant surface deterioration, raveling, and structural distresses. If severe or potentially severe joint deterioration from freeze-thaw damage or material-related distress (MRD: ASR or D-cracking) is present and it exists 3 ft to 4 ft beyond the joint at nearly every joint, then the pavement is not normally a good candidate for an overlay unless the service life is reduced.

Figure 15. Selecting appropriate concrete overlay solution for composite pavements

unbonded) will achieve the first two objectives at the lowest life-cycle cost?

Several factors should be considered when selecting either a bonded or unbonded concrete overlay of an existing composite pavement. Two predominant factors are the condition of the existing pavement and the extent of necessary pre-overlay repairs, if any.

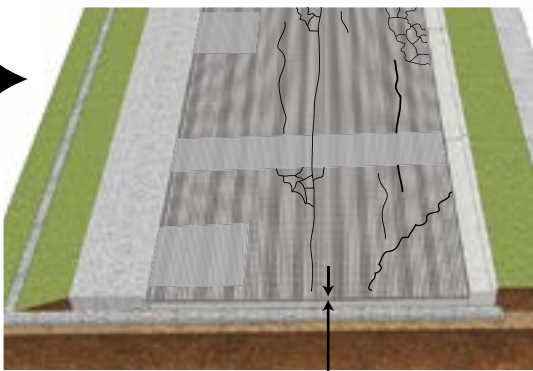
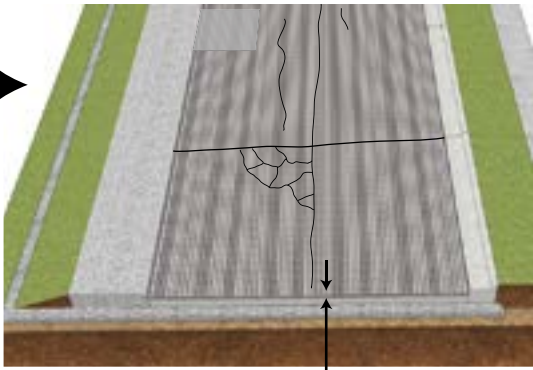
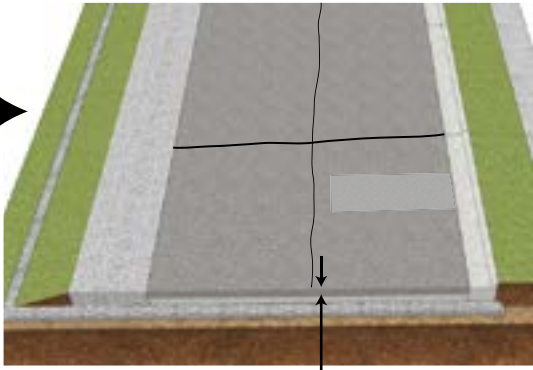

YES

NO

Generally, bonded overlays are appropriate for any composite pavement that is either in good condition or can be improved cost effectively from fair or poor condition to good condition. Composite pavements that cannot be repaired cost effectively to good condition are most likely candidates for unbonded overlays, provided that the existing pavement can serve as a subbase that provides relatively uniform support. Significant deterioration can be overlaid with concrete as long as unstable and soft spots are repaired prior to overlay construction.

A thorough pavement evaluation should be performed to determine the condition of the existing pavement and assess the scope of required pre-overlay repairs. If material-related distress (MRD: ASR, D-cracking, and/or freeze-thaw damage) is detected during the pavement evaluation, lab testing should be performed to assess the extent of MRD (see page 13 for further guidance on dealing with existing pavements with MRD).

Bonded Concrete Overlay Over Composite Pavement

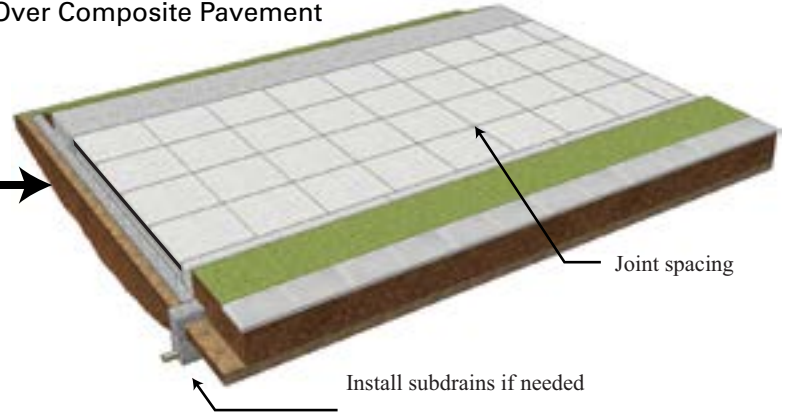

Note: Concrete overlay thickness to be appropriately designed considering estimated traffic, desired design life, and budget.

Unbonded Concrete Overlay Over Composite Pavement

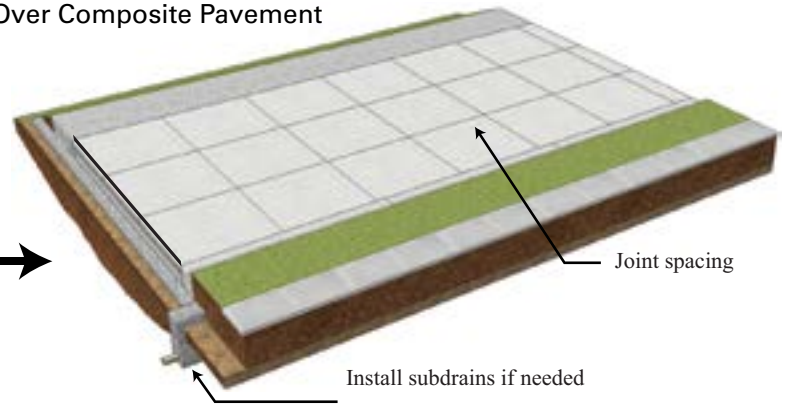

FAQ—What if the existing pavement is not a candidate for an unbonded concrete overlay? While most pavements can be preserved with an unbonded concrete overlay, there are situations where an overlay is not appropriate. When this occurs, reconstruction is an alternative. **Reconstruction options are discussed in Appendix B.** In summary, they include the following:

- **Recommended:** In-place recycling of the existing pavement to serve as a base for new pavement or shoulder material.
- **Permissible** in specific situations: Rubblizing the existing concrete pavement to serve as a base for new concrete pavement.
- **Not recommended:** Crack-and-seat to serve as a base for new pavement.

Selecting the Appropriate Concrete Overlay Solution for Concrete Pavements

Concrete overlays can provide economical short- to long-term solutions for concrete pavements. The recommendations provided in the following flowchart are generally long-term fixes on the order of 20 years or more of expected life.

As with any preservation approach, the principles of asset management

are a cornerstone in selecting the appropriate concrete overlay solution. Three important asset management questions need to be answered as part of the selection process, for the appropriate concrete overlay solution to meet the needs of an agency. First, what is the desired level of service to be provided by the concrete overlay? Second, what is the desired life of the overlay given the condition of the existing pavement? Third, what type of

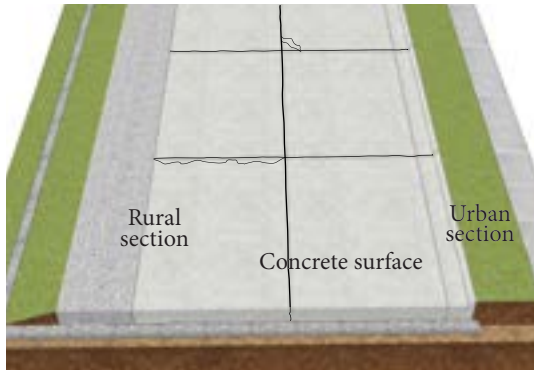

Good Condition

Pavement is structurally sound but needs increased structural capacity, improved surface characteristics (smoothness, friction and noise), corrected surface defects, and/or improved albedo properties.

Spot Repairs

Can spot surface repairs and/or spot structural repairs cost effectively solve deficiencies, bring the pavement to “Good Condition,” and meet other constraints (i.e., vertical clearance, shoulders, safety rails, foreslopes, etc.) to allow for a bonded overlay?

YES

NO ↓

Milling/Minor Spot Repairs

Can milling and minor spot repairs cost effectively remove deficiencies, bring the pavement to “Good Condition,” and meet other constraints (i.e., vertical clearance, shoulders, safety rails, foreslopes, etc.) to allow for a bonded overlay?

YES

NO ↓

Milling and Patching

Can milling and/or structural repairs (patching) cost effectively solve deficiencies, bring the existing pavement to a condition that will provide uniform support as a subbase, meet other constraints (i.e., vertical clearance, shoulders, safety rails, foreslopes, etc.), and bring the existing pavement to a condition that will provide a uniform subbase for an unbonded overlay?

YES

If deterioration is also in the bottom half of the pavement and is located at the joints, the joints can be milled or removed full depth and replaced with lower quality concrete (lean concrete) with no sawing of the joint. Cracking in the removed joint will not affect the performance of an unbonded overlay due to the interlayer.

NO

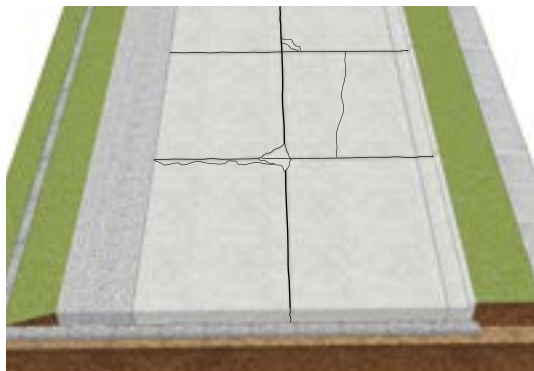

Fair Condition

Pavement is structurally sound but has minor surface distresses such as random cracking, periodic partial-depth joint spalling, and shadowing. Check for undulating profile grade to determine if sub-drainage issues or other foundation issues such as secondary consolidation of an open-graded base exist.

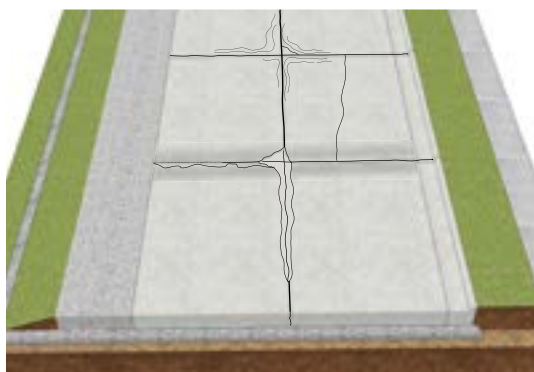

Poor Condition

Pavement has measurable surface distresses beyond those described as “Fair Condition.” These include full-depth joint deterioration, working cracks, spot structural failures, faulting, and/or material-related distresses (MRD).

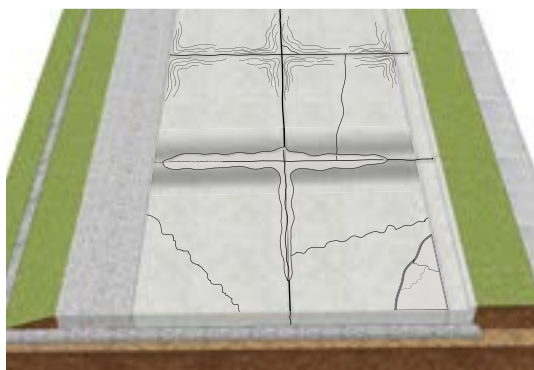

Deteriorated Condition

Pavement is in “Poor Condition” and exhibits significant surface deterioration and structural distresses. If severe or potentially severe joint deterioration from freeze-thaw damage or MRD is present and it exists 3 ft to 4 ft beyond the joint at nearly every joint, then the pavement is not normally a good candidate for an overlay unless the service life is reduced.

Figure 16. Selecting appropriate concrete overlay solution for concrete pavements

overlay (bonded or unbonded) will achieve the first two objectives at the lowest life-cycle cost?

Several factors should be considered when selecting either a bonded or unbonded concrete overlay for an existing concrete pavement. Two predominant factors are the condition of the existing pavement and the extent of necessary pre-overlay repairs, if any.

Generally, bonded overlays are appropriate for any concrete pavement that is either in good condition or

can be improved cost effectively from fair or poor condition to good condition. Concrete pavements that cannot be cost effectively repaired to a good condition are candidates for unbonded overlays, provided that the existing pavement can serve as a subbase that provides relatively uniform support. Significant deterioration can be overlaid with concrete as long as unstable and soft spots are repaired prior to overlay construction.

A thorough pavement evaluation should be performed to determine the condition of the existing pavement and assess the scope of pre-overlay repairs that may be required. If material-related distress (MRD: ASR, D-cracking, and/or freeze-thaw damage) is detected during the pavement evaluation, lab testing should be performed to assess the extent of MRD (see page 13 for further guidance on dealing with existing pavements with MRD).

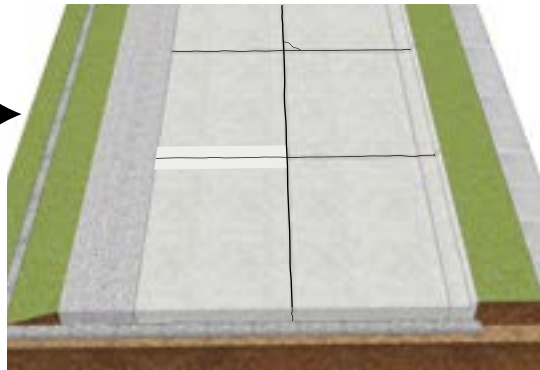

Bonded Concrete Overlay Over Concrete Pavement

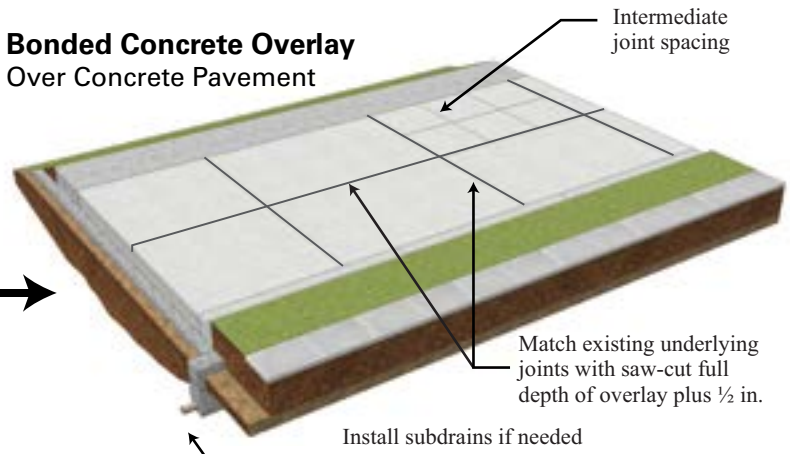

Note: Concrete overlay thickness to be appropriately designed considering: estimated traffic, desired design life, and budget.

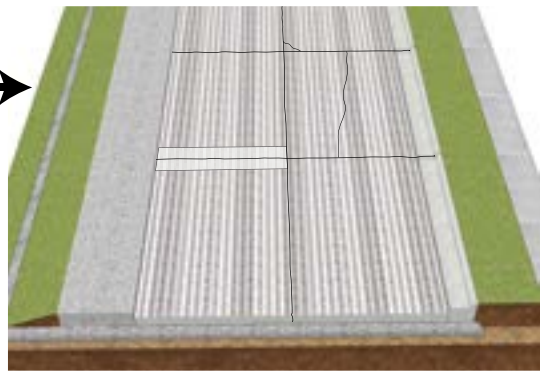

Unbonded Concrete Overlay Over Concrete Pavement

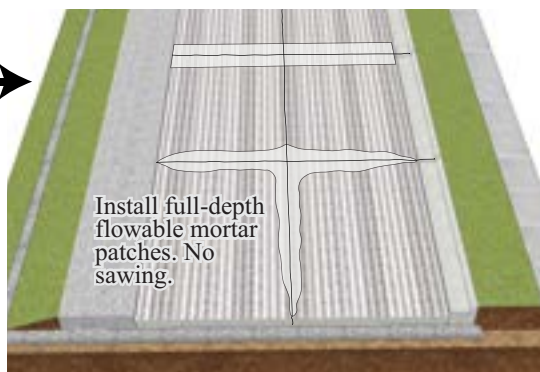
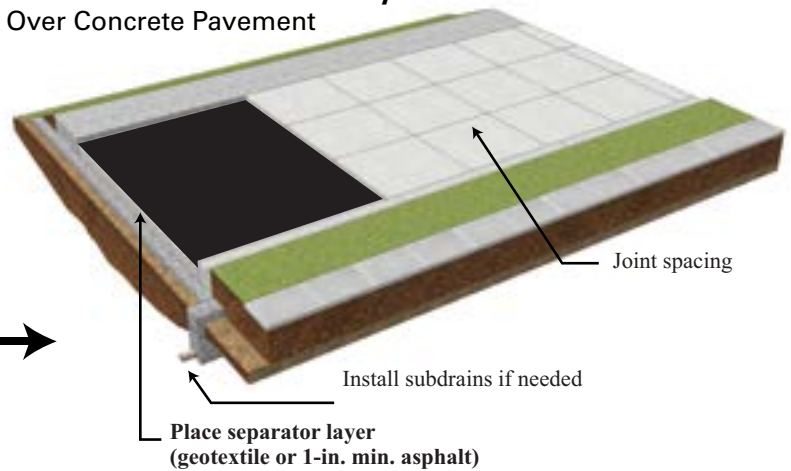

↑
YES

Additional Repairs

Can existing or potential unstable conditions or major deficiencies (e.g., wet subgrade, MRD, faulting) be addressed cost effectively through a combination of preservation techniques (e.g., milling, retrofit subdrains, full-depth patches, slab stabilization), and can other constraints (e.g., vertical clearance, shoulders, safety rails, foreslopes) be addressed with an adequately thick unbonded overlay?

NO

FAQ—What if the existing pavement is not a candidate for an unbonded concrete overlay? While most pavements can be preserved with an unbonded concrete overlay, there are situations where an overlay is not appropriate. When this occurs, reconstruction is an alternative. **Reconstruction options are discussed in Appendix B.** Following is a brief summary:

- **Recommended:** In-place recycling of the existing pavement and use as a base for new pavement or shoulder material.
- **Permissible** in specific situations: Rubblizing the existing concrete pavement to serve as a base for new concrete pavement.
- **Not recommended:** Crack-and-seat to serve as a base for new pavement.

Chapter 3.

OVERVIEW OF CONCRETE OVERLAY OPTIONS

As previously described, concrete resurfacing consists of two options: bonded overlays and unbonded overlays. Both options are applicable to all existing pavement types—i.e., on asphalt, composite, and concrete pavements. This chapter provides an overview of each of the two concrete overlay options on all existing pavement types.

Bonded concrete overlay:

1. Bonded on asphalt
2. Bonded on composite
3. Bonded on concrete

Unbonded concrete overlay:

1. Unbonded on asphalt
2. Unbonded on composite
3. Unbonded on concrete

Bonded Concrete Overlay on Asphalt Pavements

Figure 17 illustrates an asphalt pavement that may be a candidate for a bonded concrete overlay, along with the kinds of preoverlay repairs that may be appropriate.

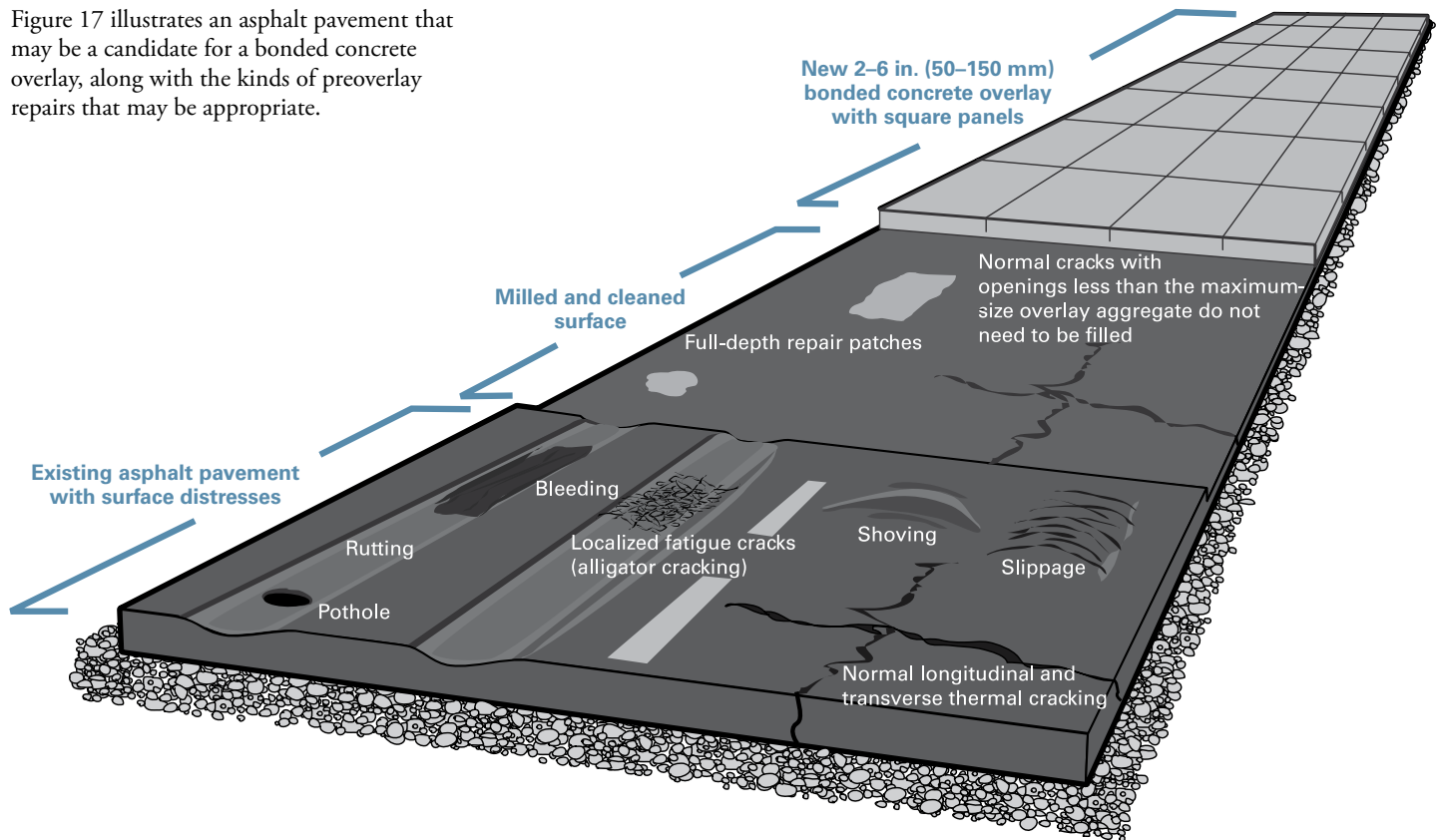

Figure 17. Bonded concrete overlay of fair or better asphalt pavement with surface distresses (previously called ultra-thin whitetopping)

Application and Uses

Bonded concrete overlays on asphalt pavements

- May be appropriate for asphalt roads, streets, and intersections in fair or better structural condition with typical distresses such as rutting, shoving, slippage, and thermal cracking; see Figure 18
- Are generally 2–6 in. (50–150 mm) thick
- Rely on the existing asphalt pavement to provide additional load-carrying capacity, and bond to the existing asphalt pavement to form a monolithic section, thereby reducing stresses and deflections
- Add structural capacity where traffic loads have increased or are anticipated to increase
- Eliminate surface defects such as rutting and shoving
- Improve surface characteristics (friction, noise, and smoothness)
- Reduce urban heat island effect by increasing pavement surface albedo

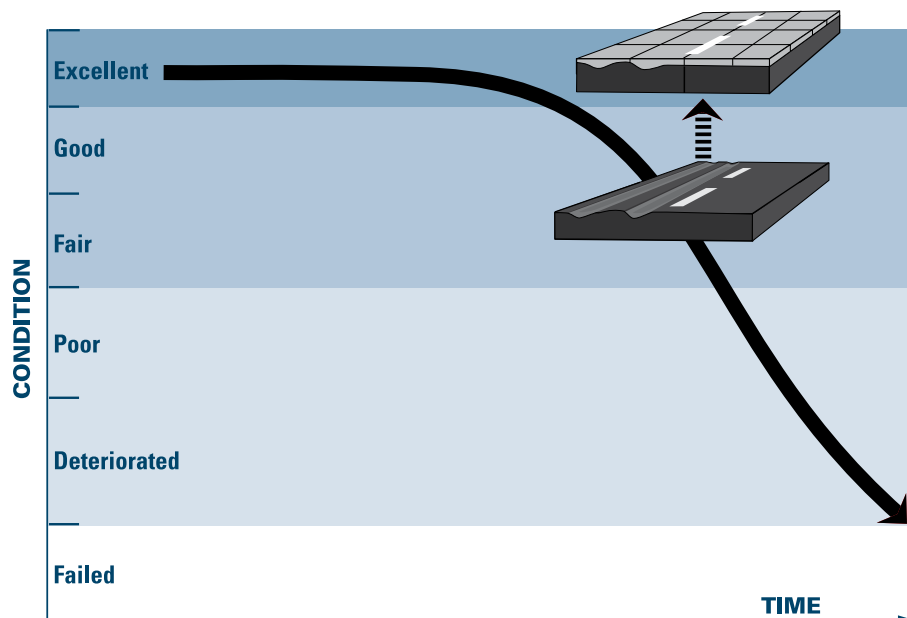

Figure 18. Bonded overlay of asphalt pavement

Performance

Bonded concrete overlays of asphalt pavements have been successfully used in many states to maintain and rehabilitate asphalt pavements with surface defects; see Figures 19 and 20. Numerous studies have shown bonded concrete overlays to offer a durable surface course provided (1) there is a sufficient bond between the asphalt surface and concrete overlay, and (2) the existing asphalt pavement provides adequate structural support.

Keys to Success

- Milling of existing asphalt may be required to eliminate or reduce surface distortions of 2 in. (50 mm) or more and to help provide a good bond.
- Minimal spot repairs may be required.
- A minimum of 3 in. (75 mm) of asphalt should remain after milling.
- Asphalt surface should be sprinkled with water when the surface temperature is greater than 120°F (49°C) during overlay placement.
- A clean surface is critical to achieving an adequate bond between the overlay and the underlying asphalt.
- Appropriate panel size should be established with respect to the thickness of the concrete overlay and should preferably be sawed in small square panels.
- Transverse joints must be sawed T/3 (with special attention to thickened overlay over asphalt ruts and other nonuniform areas).
- When feasible, design the longitudinal joints to be outside of the normal wheel paths.
- No notable stripping or delamination at tack lines exists in asphalt pavement to remain after milling.

- Thinner overlays may shorten the sawing window; additional saws are likely to be required.
- Application of curing compound or other curing methods must be timely and thorough, especially at the edges.
- Sealing joints improves performance.

Overlay Process

The overlay project consists of pavement evaluation, design, construction, and future repairs.

Pavement Evaluation

An evaluation of the existing asphalt pavement is necessary to

- Ensure it is structurally adequate to carry the anticipated traffic loads
- Determine if milling is required and to what depths
- Establish the bonded overlay design thickness

For information on pavement evaluation, see Chapter 2. Asphalt pavements with significant structural deterioration, inadequate or non-uniform base/subbase support, or stripping of asphalt layers due to inadequate drainage are not good bonded overlay candidates; in such cases, an unbonded concrete overlay should be considered.

Overlay Design

Design elements include overlay thickness, mixture design, joints, and drainage.

Overlay Thickness

The design thickness for bonded concrete overlays is typically 2–6 in. (50–150 mm), depending on the desired load-carrying capacity and service life as well as the structural

capacity provided by the underlying pavement. Additional overlay thickness may be required in transition sections to prevent movement of the overlay panels adjacent to the existing asphalt pavement and to reduce the potential for cracking due to traffic impact loadings.

The recommended thickness design procedures are those used by the American Concrete Pavement Association's *Bonded Concrete Overlay on Asphalt (BCOA) Thickness Designer* (2012) or the *BCOA ME* (Vandenbossche 2013). For more information on these procedures, see Table 10 in Chapter 4.

Mixture Design

Conventional concrete mixtures have been successfully used for bonded concrete overlays of asphalt pavements. When accelerated opening is desired, conventional concrete mixtures should be proportioned for rapid strength gain without increasing shrinkage properties. For additional information on accelerated mixtures, see page 76.

The use of high-modulus structural fibers can improve the toughness and postcracking behavior of the concrete and help mitigate the effects of plastic shrinkage cracking, should it occur. For more information, see discussion beginning on page 77.

Joint Design

The recommended joint pattern for bonded overlays of asphalt is small square panels, typically in the range of 3–8 ft (0.9–2.4 m), to reduce differential movement between the concrete overlay and asphalt and to reduce curling and warping stresses. It is recommended that the length and width of joint squares in feet be limited to 1.5 times the overlay thickness in inches. In addition, if possible, longitudinal joints should be arranged so that they are not in the wheel



Figure 19. SH-119 in 1991 prior to placement of an bonded concrete overlay (source: Ron Youngman, CO/WY chapter, ACPA)



Figure 20. SH-119 in 2009 after 18 years of service (source: Ron Youngman, CO/WY chapter, ACPA)

path; see Figure 21. The use of tiebars or dowels is not necessary because of the small panel size.

Studies performed in Iowa on low-volume roadways with bonded concrete overlays of asphalt pavement have shown that, on average, only 5 percent of the contraction joints were cracked after 10 years. These results indicate that there are potential cost savings that could be realized on similar low-volume roadways, either by increasing the slab dimensions or by reducing the concrete overlay thickness.

In the past, bonded overlays less than or equal to 6 inches thick have typically left the joints unsealed. Studies performed by

the Minnesota DOT (MnDOT 2013) have shown improved performance when joints are sealed. Because the concrete overlay is bonded to the underlying asphalt pavement, moisture that is allowed to infiltrate open joints has nowhere to drain, eventually weakening the bond and resulting in premature cracking of the slabs.

Drainage

Stripping or delamination in the upper 3 inches of the remaining asphalt layer to be overlaid can lead to premature failure of the bonded concrete overlay. During evaluation and design of a bonded concrete overlay project, existing subgrade drainage should be evaluated, as would be done with asphalt

resurfacing. If necessary, steps should be taken to ensure adequate drainage in the future (i.e., retrofit edge drains, free draining shoulder materials, geotextiles, etc.).

When underdrains are present, they should be cleaned, video inspected, and repaired as necessary.

Construction

Construction steps include preoverlay repairs, milling, surface cleaning, concrete placement, curing, joint sawing, and sealing.

Preoverlay Repairs

Before the milling operation commences, areas with potholes; localized, moderate-to-severe alligator cracking; or loss of base/subgrade support will require partial or full-depth spot repairs to provide uniform bonding and to achieve the desired load-carrying capacity and long-term durability; see Table 3.

The milled surface should be inspected for isolated pockets of deterioration that require further repairs. For isolated areas that have a high number of wide transverse thermal cracks, a decision needs to be made whether to bridge the cracks with the bonded overlay or to clean and fill the cracks. Concrete can span normal asphalt longitudinal and transverse cracks. Filling old cracks with sand, flowable fill, or other appropriate material is necessary only for cracks that have an opening greater than the maximum-size aggregate used in the overlay.

Milling

In general, milling should be minimized because it results in loss of structural support. There is no reason to mill off good asphalt that can contribute to composite action and continue to help carry traffic loads.

Typically, milling all asphalt surfaces to improve bonding is not required. The main objectives of milling prior to placing a bonded overlay are (1) to remove significant surface distortions that contain soft asphaltic material, which would result in an inadequate bonding surface; (2) to reduce high spots to help ensure minimum overlay depth and reduce the quantity of concrete needed to fill low spots; and (3) to match curb or adjacent structure elevations.

Matching existing features or minimizing the vertical change in profile grade will often be the primary criteria for determining the milling depth. When this is the case, a thorough evaluation of the thickness and condition of the existing asphalt pavement must be performed to assure that the remaining asphalt to be overlaid is sound and thick enough to provide structural support for carrying loads.

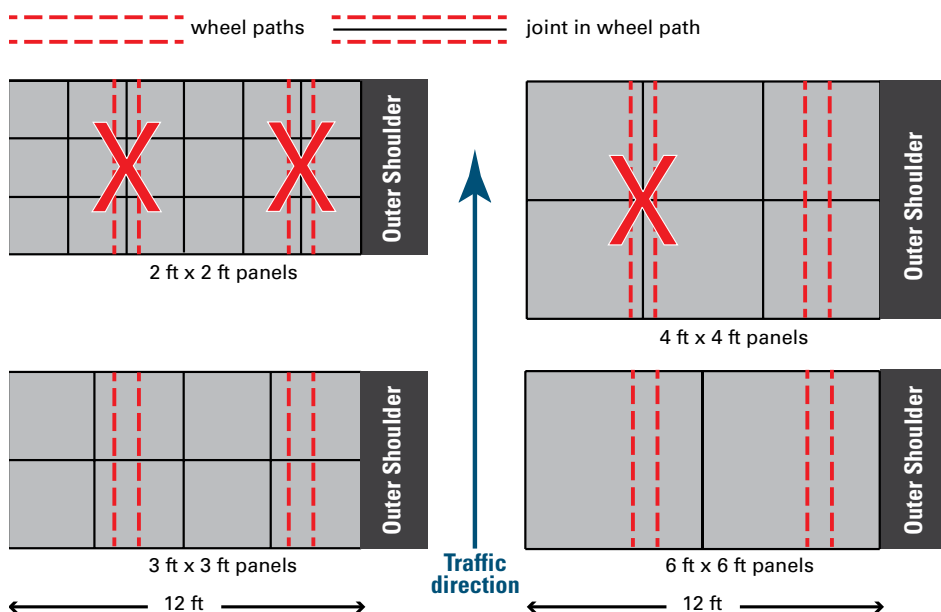

Figure 21. Longitudinal joints should be arranged to avoid wheel paths

Table 3. Possible Preoverlay Repairs on Existing Asphalt Pavement in Preparation for Bonded Overlay

Existing Pavement Distress	Spot Repairs to Consider
Rutting ≥ 2 in. (50 mm)	Mill
Rutting < 2 in. (50 mm)	None or mill
Shoving, slippage	Mill
Crack width ≥ maximum coarse aggregate size used in the concrete overlay mixture	Fill with flowable fill.
Crack width < maximum coarse aggregate size used in the concrete overlay mixture	None
Low- to medium-severity pothole	Remove loose material and fill integrally with the concrete overlay.
High-severity pothole and/or areas needing full-depth repair	To prevent a single overlay panel from bonding to both asphalt and concrete, make full-depth repairs across a full lane width with concrete and adjust the transverse joint spacing in the concrete overlay to match the location of the underlying patch. The full lane width prevents trying to match a longitudinal joint for a partial lane patch.

When milling the existing pavement to a specific profile and/or cross slope is being considered, assure that there is adequate pavement depth to maintain a minimum 3 inches of sound asphalt for bonding after the milling is completed.

Most surface distresses can be removed through milling. Milling may be used where surface distortions are 2 in. (50 mm) or greater. The amount of asphalt removed depends on the types and severity of distresses and the thickness of the asphalt. Milling can be used to remove gross irregularities that would cause quantity overruns in the volume of concrete needed for the overlay; it is not necessary to obtain a perfect cross section or to completely remove ruts. If a stripped (loose) layer of asphalt is encountered, it must be completely removed to provide a sound structural layer for bonding. The minimum thickness of structurally sound asphalt required for bonding is 3 inches.

Construction traffic—specifically, trucks loaded with concrete—can cause significant damage to the remaining asphalt pavement. An adequate layer of asphalt is required to prevent delamination, thus ensuring that the asphalt will function as a load-carrying portion of the composite section (not as a separation layer or shear plane, as in an unbonded overlay). Some construction traffic, however, can be placed on the milled surface to identify any loose material (i.e., partial lifts, deteriorated asphalt, isolated areas of stripping, etc.) remaining after the milling operation. All unsound areas should be removed prior to performing any further operations.

While the milling machine is on site, it is important that the pavement surface be inspected to determine if additional milling is required.

Surface Cleaning

Following repairs, the asphalt surface should be cleaned to ensure adequate bonding between the existing asphalt surface and the new concrete overlay. Adequate bonding is very important to the performance of this type of overlay. Cleaning may be accomplished by first sweeping the asphalt surface, then cleaning with compressed air. If material is subsequently tracked onto the pavement surface, the surface must be re-cleaned. Pressure washing should be considered only when dust control is mandated or when mud has been tracked onto the milled surface. In no case should water or moisture be allowed to stand on the asphalt pavement prior to overlay placement. To prevent contamination, it is important to avoid a lengthy lag time between final surface cleaning and paving.

Concrete Placement

When the surface temperature of the asphalt is at or above 120°F (49°C), sprinkling the surface with water can reduce the temperature and minimize the chance of early-age cracking. No standing water should remain on the surface at the time the overlay is placed. Water trapped in the milled surface can be blown off with compressed air.

Once the surface of the existing asphalt pavement has been prepared, paving is accomplished using either conventional fixed-form or slipform construction. Because of the non-uniform thickness of concrete, the concrete material is bid on a cubic-yard basis. Some states also include a bid item for placement on a square-yard basis.

Curing

Curing is especially critical on a bonded concrete overlay because its high surface area-to-volume ratio makes the thin concrete overlay more susceptible to rapid moisture loss. Within 30 minutes of placing the over-

lay, curing compound should be applied at twice the standard rate. The finished product should appear as a uniformly painted solid white surface, with the vertical faces along the edges of the overlay also thoroughly coated.

Joint Sawing

Timely joint sawing is necessary to prevent random cracking. Joint sawing should commence as soon as the concrete has developed sufficient strength so that joints can be cut without significant raveling or chipping. Lightweight early-entry saws may be used to allow the sawing crew to get on the pavement as soon as possible. With typical joint spacing of 3 to 6 feet, extra saws will likely be needed to avoid random cracking. Transverse joints can be sawed with conventional saws set to a depth of T/3. Transverse joint saw-cut depths for early-entry sawing should not be less than 1.25 in. (31 mm). Longitudinal joints should be sawed to a depth of T/3.

Joint Sealing

Contraction and construction joints should be filled with a hot-poured joint sealant (the use of backer rod is not recommended).

Future Repairs

Bonded concrete overlays on asphalt may be easily repaired using full-panel replacement. Another option is simply to mill and inlay with concrete. Do not patch with asphalt, because the adjacent concrete panels will move and break the bond. If a panel is distressed but the ride quality of the pavement is not compromised, the panel should be left in place. If a ride-quality problem develops, the panel should be replaced before any pieces of concrete become loose from the overlay.

Key Resources

ACI Committee 325 (2006); ACPA (1999); MnDOT (2013); Rasmussen and Rozycki (2004); Vandenbossche (2013)

Bonded Concrete Overlay on Composite Pavements

Figure 22 illustrates a composite pavement that may be a candidate for a bonded concrete overlay, along with the kinds of pre-overlay repairs that may be appropriate.

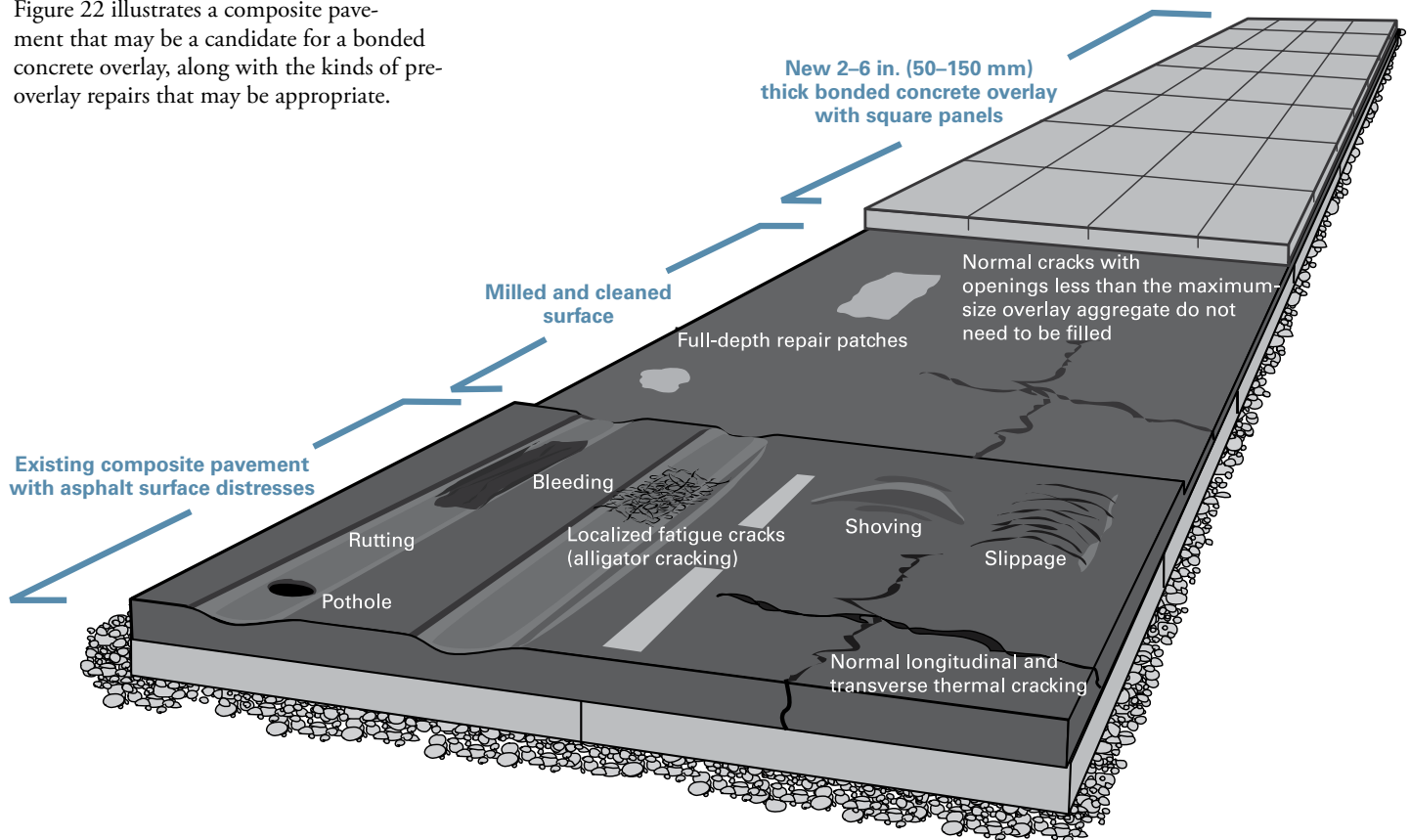

Figure 22. Bonded concrete overlay of fair or better condition composite pavement with asphalt surface distresses

Application and Uses

Bonded concrete overlays on composite (asphalt on concrete) pavements

- May be appropriate for composite roads, streets, and intersections in fair or better structural condition with typical distresses such as rutting, shoving, slippage, and thermal cracking; see Figure 23
- Are generally 2–6 in. (50–150 mm) thick
- Rely on the existing asphalt pavement to provide additional load-carrying capacity, and bond to the existing composite pavement to form a monolithic section, thereby reducing stresses and deflections
- Add structural capacity where traffic loads have increased or are anticipated to increase
- Eliminate surface defects such as rutting and shoving
- Improve surface characteristics (friction, noise, and smoothness)
- Reduce urban heat island effect by increasing pavement surface albedo

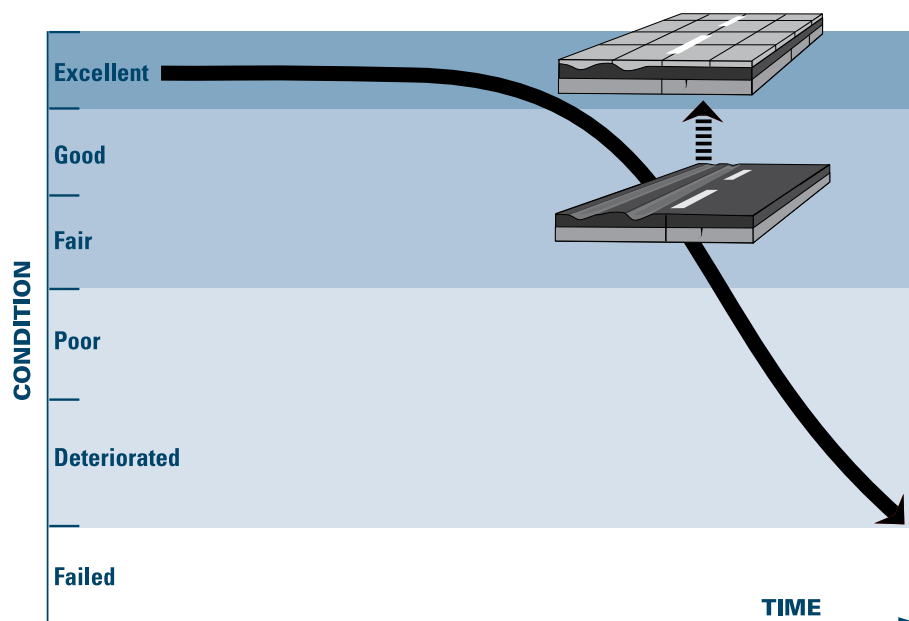

Figure 23. Bonded overlay of asphalt

Performance

Bonded concrete overlays have been successfully used in many states to maintain and rehabilitate composite pavements with surface defects; see Figures 24 and 25. The key to long-term performance is ensuring the two structures—the existing composite pavement and the overlay—move as one structure.

Keys to Success

The following actions will help ensure a successful project:

- An effective bond between the layers of the composite pavement is necessary.
- A quality bond between the concrete overlay and the composite pavement system is beneficial.
- Milling of existing asphalt may be required to eliminate or reduce surface distortions of 2 in. (50 mm) or more and to help provide a good bond.
- A minimum of 3 in. (75 mm) of asphalt should remain after milling.
- Minimal spot repairs may be required.
- The asphalt surface should be sprinkled with water when the surface temperature is greater than 120°F (49°C) during overlay placement.
- A clean surface is critical to achieving an adequate bond between the overlay and the underlying asphalt.
- An appropriate panel size should be established with respect to the thickness of the concrete overlay, and it should preferably be sawed in small square panels.

FAQ—What if the existing concrete pavement has MRD below the asphalt surface?

Material-related distresses such as D-cracking, alkali-silica reaction, and freeze-thaw joint deterioration can sometimes be difficult to detect in the underlying concrete pavement. These distresses can lead to a loss of support and premature failure of the bonded concrete overlay. Caution should be used when considering a bonded overlay when these conditions are present. Improving the drainage of the subgrade/subbase below the existing concrete (i.e., retrofit edge drains) can slow the progression of MRDs and potentially extend the life of a proposed bonded concrete overlay.

- Transverse joints must be sawed T/3 (with special attention to thickened overlay over asphalt ruts and other nonuniform areas).
- When feasible, design the longitudinal joints to be outside of the normal wheel paths.
- Thinner overlays may shorten the sawing window; additional saws are likely to be required.
- Application of curing compound or other curing methods must be timely and thorough, especially at edges.
- Sealing joints may improve performance.
- No notable stripping or delamination at tack lines should exist in asphalt pavement to remain after milling.

Overlay Process

The overlay project consists of pavement evaluation, design, construction, and future repairs.

Pavement Evaluation

An evaluation of the existing asphalt pavement is necessary (1) to ensure it is structurally adequate to carry the anticipated traffic loads, (2) to determine required milling depths, and

(3) to establish the bonded overlay design thickness. For general information on pavement evaluation, see Chapter 2.

Composite pavements are not good candidates for bonded overlays of less than 6 in. (125 mm) if they display any of the following problems:

- Significant structural deterioration, inadequate or uneven subgrade/subbase support, poor drainage conditions, or stripping or delamination of asphalt layers
- Problems in the underlying concrete (possibly reflected in the asphalt layer) due to MRD
- Indications of possible future durability problems

Overlay Design

Design elements include overlay thickness, mixture design, joints, and drainage.

Overlay Thickness

The design thickness for bonded concrete overlays is typically 2–6 in. (50–150 mm), depending on the desired load-carrying capacity and service life as well as the structural capacity provided by the underlying pavement.



Figure 24. Existing composite pavement (source: James Cable, Iowa State University)



Figure 25. Bonded on composite pavement (source: James Cable, Iowa State University)

The recommended thickness design procedures are those used by the American Concrete Pavement Association's *Bonded Concrete Overlay on Asphalt (BCOA) Thickness Designer* (2012) or the *BCOA ME* (Vandenbossche 2013). For more information on these procedures, see Table 10 in Chapter 4.

Mixture Design

Conventional concrete mixtures have been successfully used for bonded concrete overlays of asphalt pavements. When accelerated opening is desired, conventional concrete mixtures should be proportioned for rapid strength gain without increasing shrinkage properties. For additional information on accelerated mixtures, see page 76.

The use of high-modulus structural fibers can improve the toughness and postcracking behavior of the concrete and help mitigate the effects of plastic shrinkage cracking, should it occur. For more information, see page 77 and Appendix C.

Joint Design

The recommended joint pattern for bonded overlays of asphalt is small square panels, typically in the range of 3–8 ft (0.9–2.4 m), to reduce differential movements between the concrete overlay and asphalt and to reduce curling and warping stresses. It is recommended that the length and width of joint squares in feet be limited to 1.5 times the overlay thickness in inches. In addition, if possible, longitudinal joints should be arranged so that they are not in the wheel path. The use of tiebars or dowels is not necessary because of the small panel size.

In the past, bonded overlays less than or equal to 6-inches thick have typically left the joints

unsealed. Studies performed by the Minnesota DOT (2013) have shown improved performance when joints are sealed. Because the concrete overlay is bonded to the underlying asphalt pavement, moisture that is allowed to infiltrate open joints has nowhere to drain, eventually weakening the bond and resulting in premature cracking of the slabs.

Drainage

Stripping or delamination in the upper 3 inches of the remaining asphalt layers to be overlaid can lead to premature failure of the bonded concrete overlay.

During evaluation and design of a bonded concrete overlay project, existing subgrade drainage should be evaluated, as would be done with asphalt resurfacing. If necessary, steps should be taken to ensure adequate drainage in the future (i.e., retrofit edge drains, free draining shoulder materials, geotextiles, etc.).

When underdrains are present, they should be cleaned, video inspected, and repaired as necessary.

Construction

Construction steps include preoverlay repairs, milling, surface cleaning, concrete placement, curing, joint sawing, and sealing.

Preoverlay Repairs

Before the milling operation commences, areas with potholes; localized, moderate-to-severe alligator cracking; or loss of base/subgrade support will require partial or full-depth spot repairs with asphalt to provide uniform bonding and to achieve the desired load-carrying capacity and long-term durability; see Table 4.

The milled surface should be inspected for isolated pockets of deterioration that require further repairs. For isolated areas that have a high number of wide transverse thermal cracks, a decision needs to be made whether to bridge the cracks with the bonded overlay or to clean and fill the cracks. Concrete can span normal asphalt longitudinal and transverse cracks. Filling old cracks with fly ash slurry, concrete grout, flowable mortar, or other appropriate material is necessary only for cracks that have an opening greater than the maximum-size aggregate used in the bonded overlay.

Panel tenting (early stages of blowups) may be an indication that there is a void under existing panels. Sections with significant tenting should be repaired to relieve the pressure and provide uniform support before construction of a bonded overlay.

If there is vertical movement of the underlying concrete adjacent to a crack, the movement can be stopped by replacing or retrofitting the joint. The crack can also be controlled without repairing the underlying pavement by adding fibers to the mixture or, in some cases, by placing reinforcing steel over the joint in the overlay. Typically, 36-in. (900-mm) long no. 4 bars are stapled to the existing pavement at 30-in. (750-mm) spacings perpendicular to the crack.

Milling

In general, milling should be minimized because it results in loss of structural support. There is no reason to mill off good asphalt that can contribute to composite action and continue to help carry traffic loads.

Typically, milling all asphalt surfaces to improve bonding is not required. The main objectives of milling prior to placing a bonded overlay are (1) to remove significant surface distortions that contain soft asphaltic material, which would result in an inadequate bonding surface; (2) to reduce high spots to help ensure minimum overlay depth and reduce the quantity of concrete needed to fill low spots; and (3) to match curb or adjacent structure elevations. Milling may also be considered to roughen the surface, which will likely enhance bonding.

Matching existing features or minimizing the vertical change in profile grade will often be the primary criteria for determining the milling depth. When this is the case, a thorough evaluation of the thickness and condition of the existing asphalt pavement must be performed to assure that the remaining asphalt to be overlaid is sound and thick enough to provide structural support for carrying loads.

Table 4. Possible Preoverlay Repairs on Existing Composite Pavement in Preparation for Bonded Overlay

Existing Pavement Distress	Spot Repairs to Consider
Rutting ≥ 2 in. (50 mm)	Mill
Rutting < 2 in. (50 mm)	None or mill
Shoving, slippage	Mill
Crack width ≥ maximum coarse aggregate size used in the concrete overlay mixture	Fill with flowable fill.
Crack width < maximum coarse aggregate size used in the concrete overlay mixture	None
Low- to medium-severity pothole	Remove loose material and fill integrally with the concrete overlay.
High-severity pothole and/or areas needing full-depth repair	To prevent a single overlay panel from bonding to both asphalt and concrete, make full-depth repairs across a full lane width with concrete and adjust the transverse joint spacing in the concrete overlay to match the location of the underlying patch. The full lane width prevents trying to match a longitudinal joint for a partial lane patch.

When milling the existing pavement to a specific profile and/or cross slope is being considered, assure that there is adequate pavement depth to maintain a minimum 3 inches of sound asphalt for bonding after the milling is completed.

Most surface distresses can be removed through milling; see Table 4. Milling may be used where surface distortions are 2 in. (50 mm) or greater. The amount of asphalt removed depends on the types and severity of distresses and the thickness of the asphalt. The objective of milling is to remove gross irregularities that would cause quantity overruns in the volume of concrete needed for the overlay; it is not necessary to obtain a perfect cross section or to completely remove ruts. If a stripped (loose) layer of asphalt is encountered, it must be completely removed to provide a sound structural layer for bonding. The minimum thickness of structurally sound asphalt required for bonding is 3 inches.

Construction traffic—specifically, trucks loaded with concrete—can cause significant damage to the remaining asphalt pavement. An adequate layer of asphalt is required to prevent delamination, thus ensuring that the asphalt will function as a load-carrying portion of the composite section (not as a separation layer or shear plane, as in an unbonded overlay). When possible, however, some construction traffic should be placed on the milled surface to identify any loose material (i.e., partial lifts, deteriorated asphalt, isolated areas of stripping, etc.) remaining after the milling operation. All unsound areas should be removed prior to performing any further operations.

While the milling machine is on site, it is important that the pavement surface be inspected to determine if additional milling is required.

Surface Cleaning

Following repairs, the asphalt surface should be cleaned to ensure adequate bonding between the existing asphalt surface and the new concrete overlay. Adequate bonding is very important to the performance of this type of overlay. Cleaning may be accomplished by first sweeping the asphalt surface, then cleaning with compressed air. Pressure washing should be considered only when dust control is mandated or when mud has been tracked onto the milled surface. In no case should water or moisture be allowed to stand on the asphalt pavement prior to overlay placement. To prevent contamination, it is important to avoid a lengthy lag time between final surface cleaning and paving.

Concrete Placement

When the surface temperature of the asphalt is at or above 120°F (49°C), sprinkling the surface with water can reduce the temperature and minimize the chance of early-age cracking. No standing water should remain on the surface at the time the overlay is placed. Water trapped in the milled surface can be blown off with compressed air.

Once the surface of the existing asphalt pavement has been prepared, paving is accomplished using either conventional fixed-form or slipform construction. Because of the nonuniform thickness of concrete, the concrete material is bid on a cubic-yard basis. Some states also include a bid item for placement on a square-yard basis.

Curing

Curing is especially critical on a bonded concrete overlay because its high surface area-to-volume ratio makes the thin concrete overlay more susceptible to rapid moisture loss. Within 30 minutes of placing the overlay, curing compound should be applied at

twice the standard rate. The finished product should appear as a uniformly painted solid white surface, with the vertical faces along the edges of the overlay also thoroughly coated.

Joint Sawing

Timely joint sawing is necessary to prevent random cracking. Joint sawing should commence as soon as the concrete has developed sufficient strength so that joints can be cut without significant raveling or chipping. Lightweight early-entry saws may be used to allow the sawing crew to get on the pavement as soon as possible. With typical joint spacing of 3 to 6 feet, extra saws will likely be needed to avoid random cracking. Transverse joints can be sawed with conventional saws set to a depth of $T/3$. Transverse joint saw-cut depths for early-entry sawing should not be less than 1.25 in. (31 mm). Longitudinal joints should be sawed to a depth of $T/3$.

Joint Sealing

Contraction and construction joints should be filled with a hot-poured joint sealant (the use of backer rod is not recommended).

Future Repairs

Bonded concrete overlays on composite pavements may be easily repaired using full-panel replacement. Another option is simply to mill and inlay with concrete. Do not patch with asphalt, because the adjacent concrete panels will move and break the bond. If a panel is distressed but the ride quality of the pavement is not compromised, the panel should be left in place. If a ride-quality problem develops, the panel should be replaced before any pieces of concrete become loose from the overlay.

Key Resources

ACI Committee 325 (2006); ACPA (1999); MnDOT (2013); Rasmussen and Rozycki (2004); Vandenbossche (2013)

Bonded Concrete Overlay on Concrete Pavements

Figure 26 illustrates a concrete pavement that may be a candidate for a bonded concrete overlay, along with the kinds of preoverlay repairs that may be appropriate.

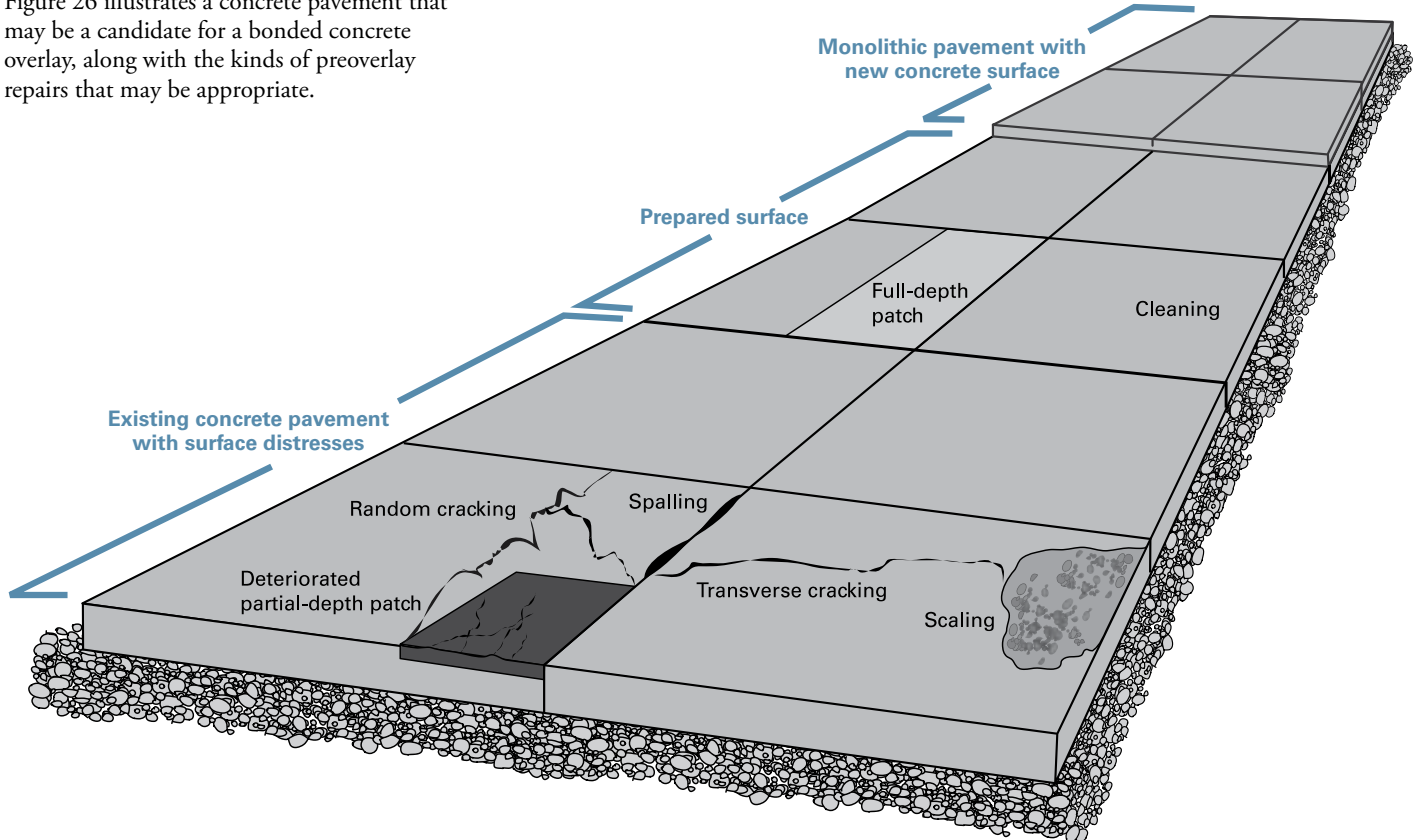

Figure 26. Bonded concrete overlay of good condition concrete pavement with surface distresses

Application and Uses

Bonded concrete overlays on concrete pavements

- May be appropriate for concrete pavements in good structural condition and with limited surface distresses; see Figure 27
- Are generally 2–5 in. (50–125 mm) thick
- Eliminate surface defects such as extensive scaling or surface cracking and/or improve surface characteristics like friction, noise, and smoothness
- Enhance structural capacity to accommodate increase in traffic loads

Performance

When properly considered, designed, specified, and constructed, bonded concrete overlays of concrete pavements have been successfully used for many years as a means of strengthening existing concrete pavements,

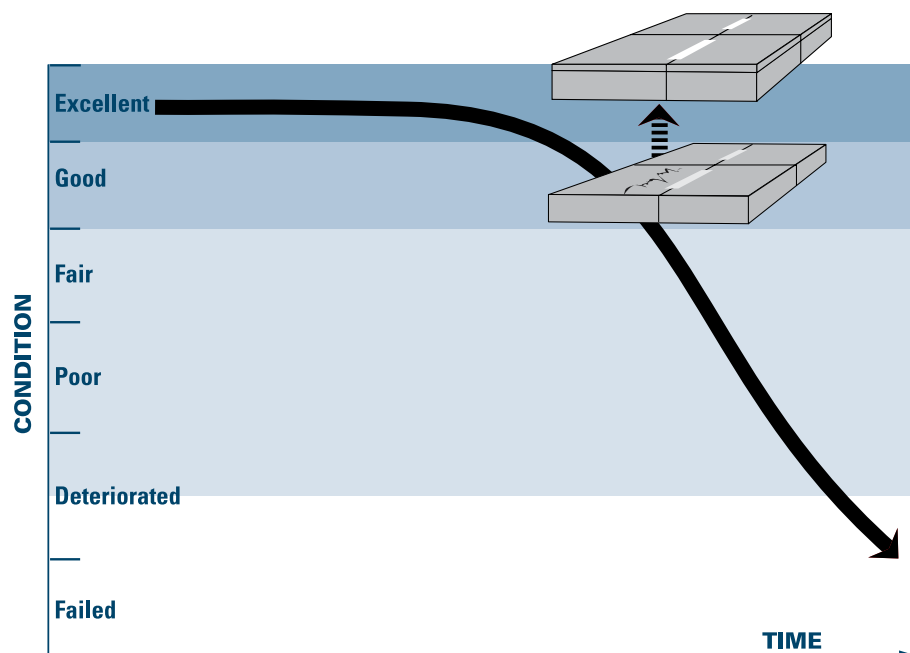

Figure 27. Bonded concrete on concrete

providing a new smooth surface, and repairing surfaces with surface defects such as scaling, high steel, plastic shrinkage cracks, etc.; see Figures 28 and 29.

They do not, however, have as high a success rate as other types of concrete overlays, primarily because of the increased attention to detail required in all phases that is sometimes overlooked in the execution of a project. The goal is to ensure the layers are bonded and react monolithically to loads. The design, specification, construction, and field supervision of any proposed bonded overlays over concrete require a commitment to proper technique. For best results, projects should be supervised by engineers and contractors experienced with this technology. Special attention needs to be given to the following items to prevent premature failure:

- A proper assessment of whether or not an existing concrete pavement is an appropriate candidate for the technique is imperative. A majority of failures of bonded concrete overlays on concrete pavements are the result of improper assessment of the existing pavement.
- The existing concrete pavement must be in good condition or brought to good condition and cleaned effectively in order for the overlay and existing pavement to bond monolithically. If debonding occurs, it leads to structural failure in the form of fatigue cracking.
- Proper specifications or supplemental specifications adapted for the specific project are necessary.
- Poor or improper surface preparation and cleaning may also lead to debonding and cracking.

- The thermal compatibility (assessed by coefficient of thermal expansion, or CTE) between the overlay and existing pavement needs to be addressed. Differential aggregate movement between the overlay and existing pavement can lead to debonding of the overlay.
- Inadequate curing and/or using oversized slab dimensions will induce higher curling and warping stresses that can stress the bond between the layers and lead to debonding.

Keys to Success

The following actions will help ensure a successful project:

- Existing concrete pavement should either be in good condition or be cost effectively brought to good condition through repairs or milling.
- The existing pavement surface must be prepared to enhance bonding to the overlay.
- The overlay's aggregate thermal properties (CTE) must be similar to (or lower than) those of the existing pavement to minimize shear stress in bond.
- Working cracks in the existing pavement should be repaired (or the overlay should be sawed over the crack) to prevent the crack from reflecting through the overlay.
- Existing joints must be in fair condition or repaired.
- Thinner overlays may shorten the sawing window.
- Transverse joints in the overlay must be sawed full depth plus 0.50 in. (12 mm),

and longitudinal joints must be sawed to a depth of at least $T/2$.

- Joints in the overlay must align with those of existing pavement because the structure must move monolithically.
- The width of transverse joints in the overlay must be equal to or greater than the underlying crack width at the bottom of the existing transverse joint (see the following page).
- An application of a curing compound or other curing methods must be timely and thorough, especially at the edges.
- To minimize curling and warping stresses, some agencies have successfully created smaller overlay panels by sawing additional transverse and longitudinal joints in the overlay between the matched joints.

Overlay Process

The overlay project consists of pavement evaluation, design, construction, and future repairs.

Pavement Evaluation

An evaluation of the existing concrete pavement is necessary to ensure that it is a good candidate for a bonded overlay and that, once resurfaced, it will be structurally sound enough to carry anticipated traffic loads. For general information on pavement evaluation, see Chapter 2.

If an existing concrete pavement exhibits cracking from expansion caused by MRD, such as ASR or D-cracking, it is not a good candidate for a bonded concrete overlay (see page 13 for a discussion of MRD). An unbonded overlay may be considered.



Figure 28. Photo of concrete pavement with shotblast surface prior to concrete overlay in 1994 (source: Todd Hanson, Iowa DOT)



Figure 29. Three-inch concrete bonded overlay (photo dated 2013) (source: Todd Hanson, Iowa DOT)

Overlay Design

Design elements include overlay thickness, mixture design, joints, and drainage.

Overlay Thickness

A bonded concrete overlay relies on the existing concrete pavement as an integral structural component to carry traffic loading. The overlay is bonded to the existing concrete pavement to form a monolithic section, thereby reducing stresses and deflections.

Under certain conditions, a mill and inlay can be used if the existing pavement has significant surface issues but is structurally sound and the subbase/subgrade is stable (Harrington et al. 2014).

The design thickness for bonded concrete overlays is typically 2–5 in. (50–125 mm), depending on the desired load-carrying capacity and service life as well as the structural capacity provided by the underlying pavement. Some states, such as Colorado, have used 6-in. (150-mm) bonded overlays on high-traffic roads.

Thickness is commonly determined using an established design procedure such as the *AASHTO Guide for Design of Pavement Structures* (AASHTO 1993, 1998). Agencies are becoming increasingly familiar, however, with the procedure in the *Mechanistic-Empirical Pavement Design Guide* (M-E PDG) (AASHTO 2008) as well. For more information, see Table 10 in Chapter 4.

Mixture Design

Conventional concrete mixtures have been successfully used for bonded concrete overlays of concrete pavements. When accelerated opening is desired, conventional concrete mixtures should be proportioned for rapid strength gain without increasing shrinkage properties. For additional information on accelerated mixtures, see page 76.

The use of high-modulus structural fibers can improve the toughness and postcracking behavior of the concrete and help mitigate the effects of plastic shrinkage cracking, should it occur. For more information, see page 77 and Appendix C.

Regarding concrete aggregate, several issues should be considered:

- A well graded aggregate will reduce the water and paste content of the mixture, thus reducing potential shrinkage and curling, as well as the related risk of debonding.
- The maximum aggregate size of the overlay concrete should be one-third of the overlay thickness.

- Aggregate with CTE similar to or lower than that of the existing concrete pavement will help ensure the two layers move together, thus reducing stresses at the bond interface.
- Pore space in the aggregate should be fully saturated before batching (moisture condition greater than saturated-surface-dry); otherwise, the aggregate will tend to pull water from the mixture at early ages, increasing the possibility of shrinkage, which can lead to debonding.

Joint Design

The bonded overlay joint type, location, and width must precisely match those of the existing concrete pavement in order to create a monolithic structure. Matched joints eliminate reflective cracking and ensure that the two layers of the pavement structure move together, helping maintain bonding. To minimize curling and warping stresses, some agencies have successfully created smaller overlay panels by sawing additional transverse and longitudinal joints in the overlay between the matched joints.

An important element in transverse joint design is joint dimensions. The depth should be full depth plus 0.50 in. (13 mm). To prevent debonding, the width of the transverse joint should be equal to or greater than the width of the underlying joint or crack in the existing pavement; see Figure 30.

The width of the existing underlying pavement crack may be determined by spot-excavating along the pavement edge. (If the pavement system experiences expansion and the overlay pushes against itself because the width of the transverse overlay joint is less than the width of the underlying existing pavement crack, debonding may occur.)

Some agencies believe that T/2 is sufficient for longitudinal joint depth. Others recommend sawing longitudinal joints full depth plus 0.50 in. (13 mm) to cut through the bond line.

Tiebars, dowel bars, or other embedded steel products are not used in bonded concrete overlays to minimize restraint forces in the bond.

Except for joint design, bonded overlays on existing continuously reinforced concrete pavements (CRCP) are designed, prepared, and constructed the same way as bonded concrete overlays on jointed plain concrete pavements (JPCP). Transverse joints are not cut in bonded concrete overlays over CRCP pavements. Acceptable cracking will occur in the bonded overlay, typically (but perhaps not immediately) over existing cracks in the CRCP.

Drainage

During evaluation and design of a bonded concrete overlay project, existing subgrade drainage should be evaluated, as would be done with asphalt resurfacing. If necessary, steps should be taken to ensure adequate drainage in the future (i.e., retrofit edge drains, free draining shoulder materials, geotextiles, etc.).

When underdrains are present, they should be cleaned, video inspected, and repaired as necessary.

Construction

Construction steps include preoverlay repairs, milling, surface cleaning, concrete placement, curing, and joint sawing.

Preoverlay Repairs

Preoverlay repairs of certain distresses may be necessary to achieve the desired load-carrying capacity and long-term durability. The surface should be inspected for isolated pockets of deterioration that require repairs; see Table 5.

For isolated areas that have wide random cracks or working joints, full-depth repairs may be necessary. When cracks (particularly working cracks) exist in the pavement to be resurfaced, reflective cracking will almost

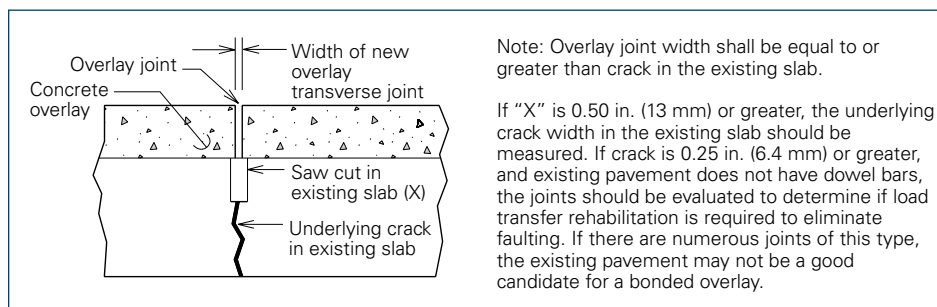

Figure 30. Width of transverse joint in bonded concrete overlay on concrete pavement should be equal to or greater than width of crack in existing pavement

always occur. Crack cages over existing non-working cracks have been successfully used to prevent reflective cracking; see Figure 31.

When voids are detected under existing slabs, the slabs should be stabilized through grout injection or other methods. Asphalt patches should be removed and replaced with concrete patches (or simply filled with concrete at the time of overlay placement) to ensure bonding of the concrete layers.

A consideration in performing repairs is whether or not movement in the underlying pavement will cause movement in the overlay. Any movement in the overlay that does not occur at matched joints could contribute to debonding and subsequent failure of the overlay.

Surface Preparation

Surface preparation of the existing concrete pavement is accomplished to produce a roughened surface that will enhance bonding between the two layers. A variety of surface preparation procedures may be used, including shotblasting, milling, high water-pressure blasting, and sandblasting.

The most commonly used and most effective surface preparation procedure is shotblasting. Although milling will roughen the concrete pavement surface, milling should not be used solely for that purpose because of its potential for causing surface microcracking and fracturing the exposed aggregate. If milling is used to lower the pavement elevation, any resulting microcracking should be removed by shotblasting or high water-pressure blasting.

Surface Cleaning

Following surface preparation, the concrete surface should be cleaned to ensure adequate bonding between the existing concrete surface and the new concrete overlay. Cleaning may be accomplished by sweeping the concrete surface, followed by cleaning in front of the paver with compressed air. If material is subsequently tracked onto the pavement surface, the surface must be re-cleaned. Paving should commence soon after cleaning to minimize the chance of contamination.

Vehicles should be limited on the existing surface after it is prepared. If it is absolutely necessary to have vehicles on the existing

concrete, care should be taken that they do not drip oil or other contaminants that could compromise the bond.

Concrete Placement

Grade adjustments may be made to ensure the required thickness of the concrete. Conventional concrete paving practices and procedures are followed for bonded concrete overlays. A bonding grout or epoxy coating of the existing surface to enhance bond is not required.

Curing

Curing is especially critical on a bonded concrete overlay because its high surface-area-to-volume ratio makes the thin concrete overlay more susceptible to rapid moisture loss. Within 30 minutes of placing the overlay, curing compound should be applied at twice the standard rate. The finished product should appear as a uniformly painted solid white surface, with the vertical faces along the edges of the overlay also thoroughly coated.

Joint Sawing

Timely joint sawing is necessary to prevent random cracking. Sawing should begin as soon as the concrete is strong enough that joints can be cut without significant raveling or chipping.

If lightweight early entry saws are used for transverse joints, it must be remembered that the depth of the saw cut must be the thickness of the overlay plus 0.5 inch and the width of the saw cut must be equal to or greater than the width of the underlying joint or crack in the existing pavement. This may require resawing the transverse joint with a conventional saw to meet these requirements.

To help match transverse joint locations, place guide nails on each edge of the existing pavement at the joints; after the overlay is placed, mark the joint with a chalk line connecting the guide nails.

Future Repairs

The recommended repair option for bonded concrete overlays on concrete is full-panel replacement. Concrete panels are easily removed and replaced. Another option is simply to mill and inlay with concrete. If a panel is cracked or otherwise distressed but the ride quality of the pavement is not compromised, the panel may be left in place.

Key Resources

ACI Committee 325 (2006); ACPA (1990a); Trevino et al. (2004)

Table 5. Possible Preoverlay Repairs on Existing Concrete Pavement in Preparation for Bonded Overlay

Existing Pavement Distress	Spot Repairs to Consider
Random cracks	Reflective cracking is likely if no repairs are made; use crack cages or full-depth repairs for severe cracks
Faulting	Slab stabilization
Pumping	Slab stabilization
Asphalt patch	Replace with concrete patch to ensure bonding
Joint spalling	Partial-depth repair
Scaling	Remove with cleaning

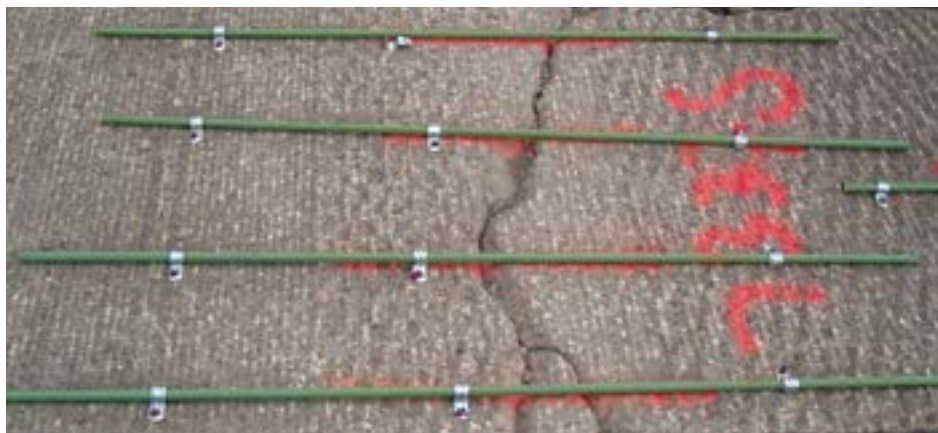

Figure 31. Crack cage over concrete pavement crack (source: James Cable)

Unbonded Concrete Overlay on Asphalt Pavements

Figure 32 illustrates an asphalt pavement that may be a candidate for an unbonded concrete overlay, along with the kinds of preoverlay repairs that may be appropriate.

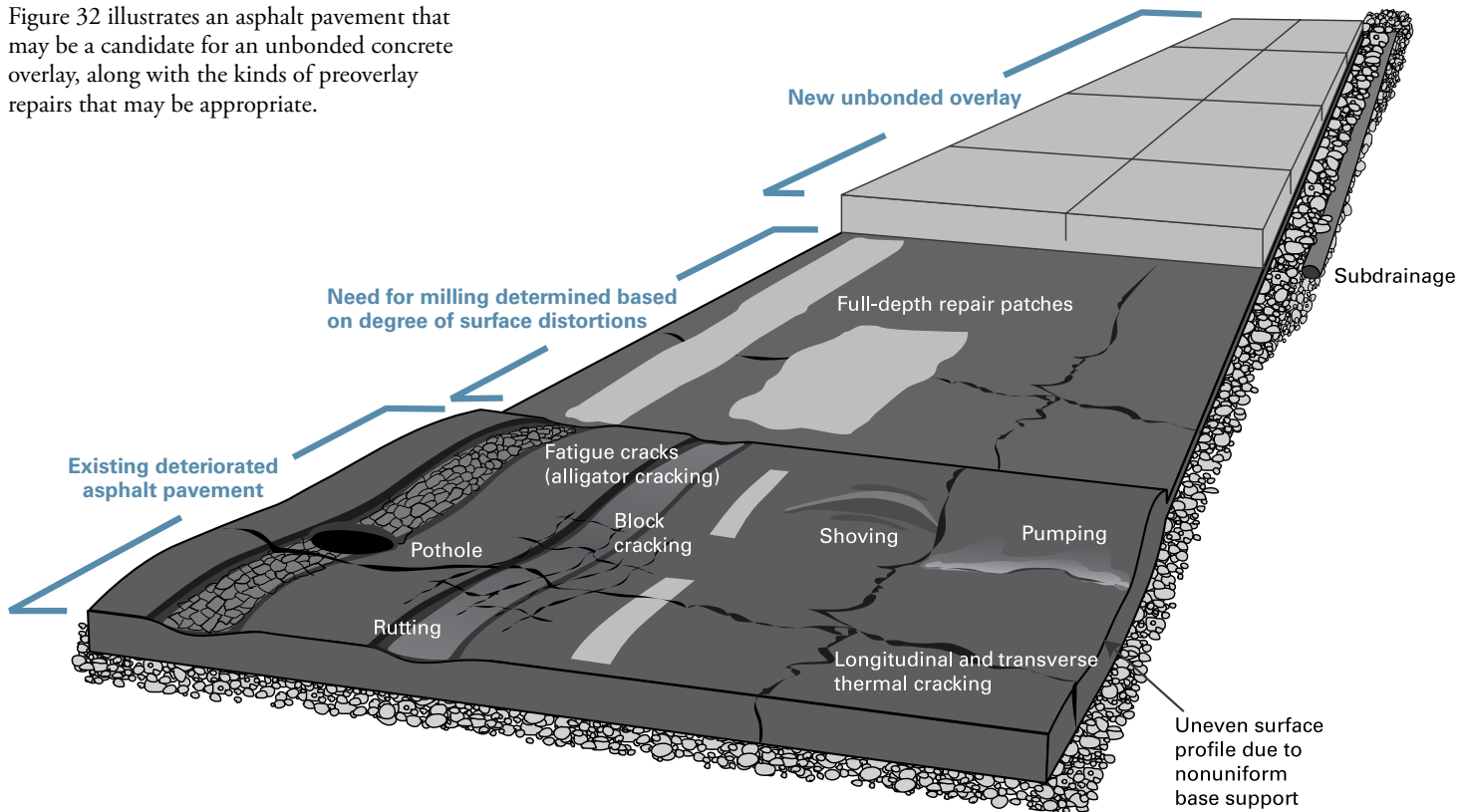

Figure 32. Unbonded concrete overlay (previously called conventional whitetopping) of poor-to-deteriorated condition asphalt pavement

Application and Uses

Unbonded concrete overlays on asphalt pavements

- May be appropriate for asphalt pavements with significant deterioration such as severe rutting, potholes, alligator cracking, subgrade/subbase issues, shoving, and pumping; see Figure 33
- Are generally 4–11 in. (100–280 mm) thick (JPCP or CRCP)
- Are essentially designed as a new concrete pavement on a stable base course, assuming an unbonded condition between the layers
- Restore or increase the structural capacity of existing pavement
- Eliminate surface defects such as rutting and shoving
- Improve surface characteristics (friction, noise, and smoothness)
- Reduce urban heat island effect by increasing pavement surface albedo

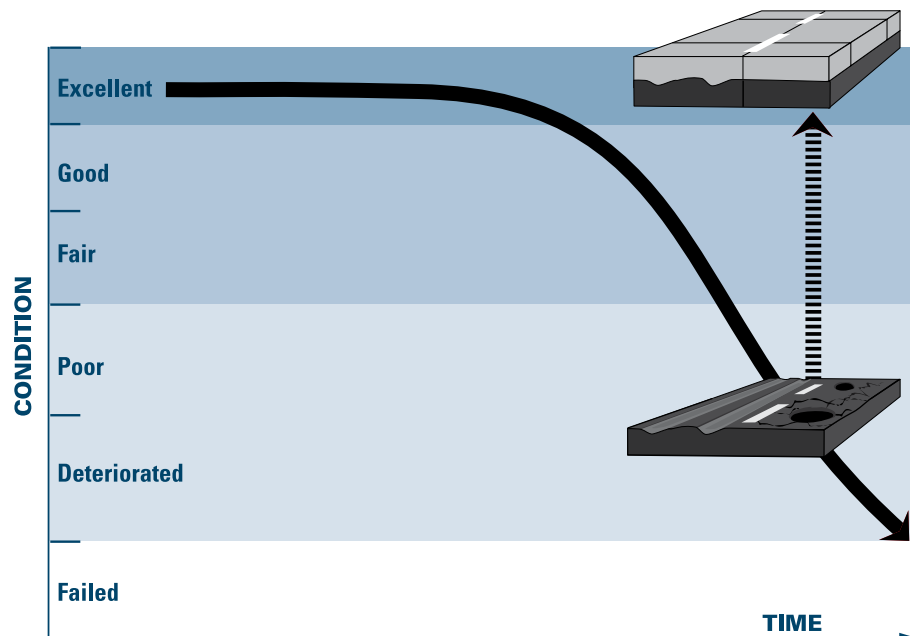

Figure 33. Unbonded concrete overlay of asphalt pavement

Performance

Unbonded overlays of asphalt pavements have been successfully used in many states, with more than 30 years of good-to-excellent performance in states such as California and Iowa. See Figures 34 and 35. Unbonded overlays over asphalt do not require extensive preoverlay repairs, but spot repairs of certain areas may be necessary to minimize localized failures. Though this overlay type does not rely on bonding, some partial bonding between the overlay and existing asphalt pavement may occur and can contribute to better performance of the pavement.

Keys to Success

The following actions will help ensure a successful project:

- Milling of existing asphalt may be required to eliminate surface distortions of 2 in. (50 mm) or more.
- Full-depth repairs should be considered only at isolated spots where structural integrity needs restoring.
- Concrete patches in the existing asphalt pavement surface should be separated from the overlay with a thin layer of geotextile fabric or other bond breaker.
- Shorter joint spacing in the overlay can help reduce curling and warping stress.
- Joints should be sawed in the overlay as soon as possible because the sawing window may be shorter than it typically is for full-depth pavements.
- The asphalt surface should be sprinkled with water when the surface temperature is greater than 120°F (49°C) during overlay placement.

- Partial bonding between the overlay and the asphalt layer of the existing composite pavement is acceptable and may improve load-carrying capacity.
- No notable asphalt stripping should exist in the asphalt after milling.

Overlay Process

The overlay project consists of pavement evaluation, design, construction, and future repairs.

Pavement Evaluation

An evaluation of the existing asphalt pavement is necessary to ensure it is a good candidate for an unbonded overlay. The objectives of the evaluation are to (1) estimate the existing pavement's structural contribution as a subbase, (2) determine the type and extent of preoverlay repairs, and (3) characterize key inputs to the overlay design (e.g., the foundation support value should be determined to establish a thickness design that accounts for the contribution of the asphalt layer[s]).

Asphalt pavements are good candidates for unbonded overlays if the existing asphalt layer(s) can provide, or can be cost-effectively repaired to provide, a uniform, stable platform for the overlay.

For general information on pavement evaluation, see Chapter 2.

Overlay Design

Design elements include using the existing pavement as a base, overlay thickness, mixture design, joints, and drainage.

Existing Pavement as Base

In an unbonded overlay design, the existing asphalt pavement is considered as a stable

base, and the overlay is designed essentially as a new concrete pavement. The design assumes an unbonded condition between the layers. There are two approaches to assessing the potential structural contribution of the existing asphalt pavement to the new pavement system. The approach in the *AASHTO Guide for Design of Pavement Structures* (AASHTO Design Guide) (1993, 1998) considers the modulus of subgrade reaction (k -value). The M-E PDG (AASHTO 2008) considers both friction and k -value.

Overlay Thickness

Unbonded overlay thicknesses typically range from 4 to 11 in. (100 to 280 mm). Unlike bonded overlays where there is a minimum thickness of asphalt required for structural support, the existing asphalt need only provide a stable and uniform subbase for the unbonded overlay. Regardless of whether the asphalt will be milled because of vertical constraints or remain in its existing condition, the minimum thickness of asphalt to be overlaid must be adequate to provide a stable working platform capable of withstanding all anticipated construction traffic (specifically, trucks loaded with concrete); this would typically be 3–4 inches of remaining asphalt or equivalent support from other underlying materials such as a chip seal surface(s).

Portions of a project with significantly different existing pavement and subbase conditions can be broken into separate sections and designed to specifically address those given conditions.

The AASHTO Design Guide (1993, 1998) and M-E PDG (AASHTO 2008) provide design procedures. For more information, see Chapter 4.



Figure 34. Poor to deteriorated asphalt pavement to be resurface (source: Todd Hanson, Iowa DOT)



Figure 35. Poor to deteriorated asphalt pavement resurfaced with unbonded concrete overlay (source: Kevin Merryman, Iowa DOT)

Mixture Design

Conventional concrete mixtures have been successfully used for unbonded concrete overlays of asphalt pavements. When accelerated opening is desired, conventional concrete mixtures should be proportioned for rapid-strength gain without increasing shrinkage properties. For additional information on accelerated mixtures, see Chapter 7.

Joint Design

The load transfer design is the same as for new concrete pavements. Doweled joints are used for unbonded overlays of pavements that will experience significant truck traffic, typically pavements 7 in. (175 mm) and thicker.

For overlays equal to or less than 6 in. (150 mm) thick, the maximum spacing in feet is 1.5 times the slab thickness in inches.

For overlays greater than 6 in. (150 mm), a maximum joint spacing in feet of 2 times the slab thickness in inches is often recommended for unbonded overlays. A 7-in. (175-mm) overlay would thus receive a maximum 14-ft (4.3-m) joint spacing. The maximum recommended spacing is typically 15 ft (4.6 m).

For situations where the design requires mechanical load transfer across the joints and the pavement is less than 7 inches in thickness, conventional dowels cause slipform paving clearance problems. Smaller diameter dowels do not significantly help the clearance issue and may not provide long-term load transfer because of potential socketing in concrete. One solution that should be considered is the use of structural fibers to help hold cracks and joints together. Additionally, the use of plate dowels provides clearance for the paver and allows for mechanical load transfer. The performance of plate dowels in transverse contraction joints is not well understood in concrete overlay pavements 5 inches or less. They have, however, been successfully used in industrial parking lots. The effects of exposure of epoxy or galvanized coated plate dowels to deicing salts is also limited. It is recommended that a proven and tested corrosion-resistant surface be required. Research on plate dowels in concrete overlays is being conducted at the MnROAD facility (Burnham and Izevbekhai 2012). See Chapter 4 for additional information on plate dowels.

The use of tiebars for unbonded overlays should follow conventional use for pavements 5 in. (125 mm) thick or more. Using lane tiebars may be appropriate in open-ditch (or shoulder) sections of unbonded overlays if the overlay is 5 in. (125 mm) or greater. In this category, a no. 4 tiebar (0.50 in. [13 mm]) may be appropriate. The use of tiebars in confined curb-and-gutter sections should be

considered if the overlay is 6 in. (150 mm) or greater.

Typical joint sealing practices should be followed.

Drainage

Stripping of the existing asphalt can lead to nonuniform support of the unbonded overlay. During evaluation and design of an unbonded concrete overlay project, existing subgrade drainage should be evaluated, as would be done with asphalt resurfacing. If necessary, steps should be taken to ensure adequate drainage in the future for the existing asphalt (i.e., retrofit edge drains, free draining shoulder materials, geotextiles, etc.). When underdrains are present, they should be cleaned, video inspected, and repaired as necessary.

Construction

Construction elements may include direct placement, preoverlay repairs, milling, patch preparation, surface cleaning, concrete placement, curing, and joint sawing.

Direct Placement

Direct placement without milling is recommended when rutting in the existing asphalt pavement does not exceed 2 in. (50 mm). Any ruts in the existing pavement are filled with concrete, resulting in a thicker overlay above the ruts.

Preoverlay Repairs

Unbonded overlays generally require only minimal preoverlay repairs of the existing asphalt; see Table 6. If significantly distressed areas are not shifting or moving and the subgrade/subbase is stable, costly repairs typically are not needed, particularly with an adequately designed overlay.

Milling

If surface distortions in the existing pavement are 2 in. (50 mm) or greater, milling may be considered prior to placing an unbonded overlay. Milling can (1) reduce high spots to help ensure minimum overlay depth, and (2) remove significant surface distortions that contain fractured asphalt material.

Spot milling only significant distortions, typically 1–2 in. (25–50 mm), is often adequate. The objective of milling is not to obtain a perfect cross section, and it is not necessary to completely remove ruts. There is no reason to mill off good asphalt that can help carry traffic loads. If a stripped (loose) layer of asphalt is encountered, it should be completely removed. Matching existing features or minimizing the vertical change in profile grade will often be the primary criteria for determining the milling depth. When this is the case, a thorough evaluation of the thickness and condition of the existing asphalt pavement must be performed to assure that the remaining asphalt to be overlaid is sound and thick enough to serve as a subbase and construction platform.

An adequate layer of asphalt (3 in. [75 mm] minimum) must remain to ensure that the asphalt will function as a uniform subbase for the unbonded overlay structure. Regardless of whether the asphalt will be milled because of vertical constraints or remain in its existing condition, the minimum thickness of asphalt to be overlaid must be adequate to provide a stable working platform capable of withstanding all anticipated construction traffic (specifically, trucks loaded with concrete).

Patch Preparation

If any full-depth concrete patches exist in the underlying pavement, each concrete patch should be isolated to prevent its bonding to

Table 6. Possible Preoverlay Repairs on Existing Asphalt Pavement in Preparation for Unbonded Overlay

Existing Pavement Condition	Possible Repairs to Consider
Area of subgrade/subbase failure	Remove and replace with stable material; correct water problems.
Severe distress that results in variation in strength of asphalt	Remove and replace with stable material; correct water problems.
Potholes	Fill with asphalt.
Shoving	Mill
Rutting ≥ 2 in. (50 mm)	Mill
Rutting < 2 in. (50 mm)	None or mill
Crack width ≥ maximum coarse aggregate size used in the concrete overlay mixture	Fill with asphalt or flowable fill.
Crack width < maximum coarse aggregate size used in the concrete overlay mixture	None

the concrete overlay. If bonding occurs, the overlay over the patch will be restrained differently than the rest of the overlay over asphalt, potentially resulting in cracking. To isolate the patch, place a geotextile fabric or asphalt slurry seal to the patch surface after milling.

Surface Cleaning

Before concrete placement, the asphalt surface should simply be swept. Remaining small particles are not considered a problem.

Concrete Placement

When the surface temperature of the asphalt is at or above 120°F (49°C), sprinkling the surface with water can reduce the temperature and minimize the chance of early-age cracking. No standing water should remain on the surface at the time of overlay placement.

Conventional concrete paving practices and procedures are followed for placing, spreading, consolidating, and finishing the unbonded overlay. Because of the variation of the thickness of concrete, the concrete material is bid on a volume (cubic-yard) basis. Some states also include a bid item for placement, measured on a square-yard basis.

Curing

Good curing practices are especially critical to thin unbonded overlays because of their high surface-area-to-volume ratio. This is accomplished by applying a curing compound immediately after surface texturing; if the unbonded overlay is 6 in. (150 mm) or thinner, use twice the usual rate of curing compound. The finished product should appear as a uniformly painted solid white surface, with the vertical faces along the edges of the overlay also thoroughly coated.

Joint Sawing

Timely joint sawing is necessary to prevent random cracking. Transverse and longitudinal joints should be sawed to a depth of $T/3$.

When there is evidence of some wheel rutting on the existing asphalt pavement, adjust the saw-cut depth to account for distortions in the underlying asphalt pavement, which effectively increases the slab thickness; see Figure 36.

Future Repairs

The recommended repair option for unbonded overlays is the same as for standard concrete pavements.

Key Resources

ACI Committee 325 (2006); ACPA (1998); FHWA (2002a)

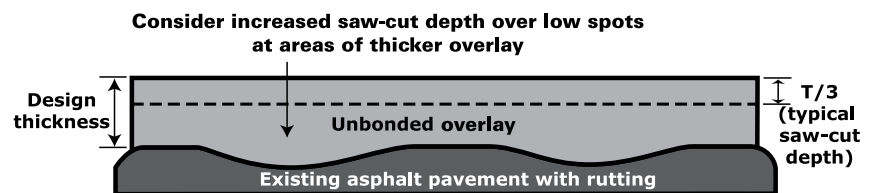

Figure 36. Consider asphalt rut depth when determining saw-cut depth (ACPA 1998)

Unbonded Concrete Overlay on Composite Pavements

Figure 37 illustrates a composite pavement that may be a candidate for an unbonded concrete overlay, along with the kinds of pre-overlay repairs that may be appropriate.

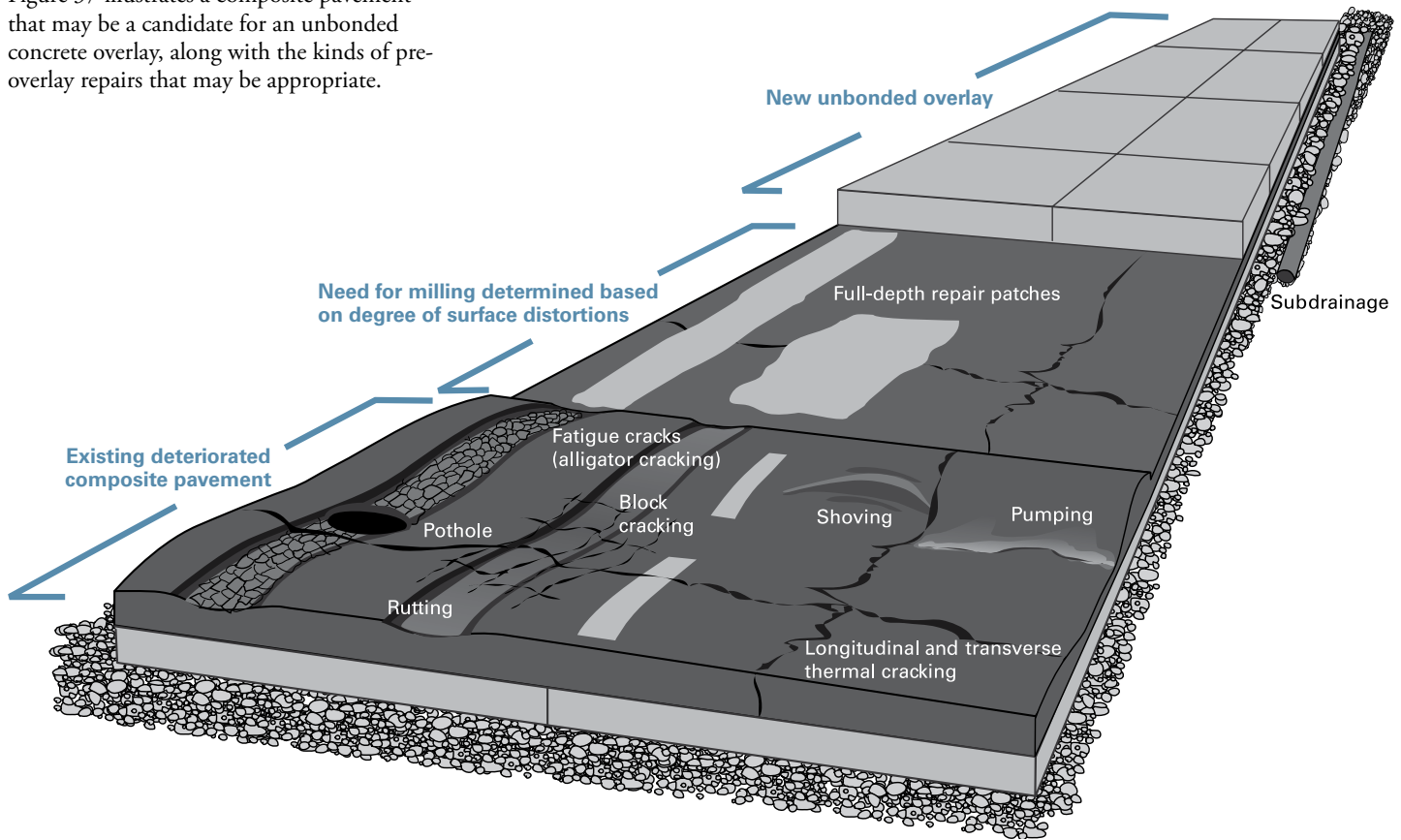

Figure 37. Unbonded concrete overlay of poor-to-deteriorated condition composite pavement

Application and Uses

- May be appropriate for composite pavements with significant HMA deterioration such as severe rutting, potholes, alligator cracking, subgrade/subbase issues, shoving, and pumping; see Figure 38
- Are generally 4–11 in. (100–280 mm) thick (JPCP or CRCP)
- Are essentially designed as a new concrete pavement on a stable base course
- Restore or increase the structural capacity of existing pavement
- Eliminate surface defects such as asphalt rutting, shoving, potholes, and concrete with mild MRD or joint deterioration
- Improve surface characteristics (friction, noise, and smoothness)
- Reduce urban heat island effect by increasing pavement surface albedo

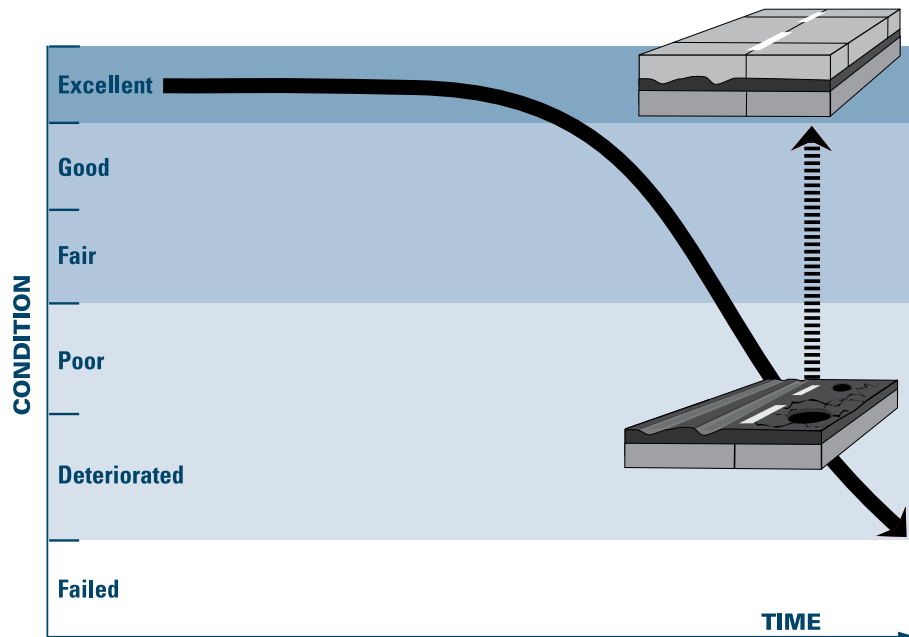

Figure 38. Unbonded overlay of composite

Performance

Unbonded overlays have the potential to greatly extend the life of existing composite pavements; see Figures 39 and 40. Uniform base support from the existing asphalt and concrete is an important factor affecting performance. Though this overlay type does not rely on bonding, some partial bonding between the resurfacing and existing asphalt pavement can contribute to enhanced performance of the pavement. Unbonded overlays of composite pavements do not require extensive preoverlay repairs, but spot repairs may be necessary to minimize localized failures.

Keys to Success

The following actions will help ensure a successful project:

- Milling of existing asphalt may be required to eliminate surface distortions of 2 in. (50 mm) or more.
- If the existing pavement profile indicates isolated areas of vertical distortion in the underlying concrete that could signal movement from inadequate drainage or MRDs, repairs may be necessary.
- Full-depth repairs should be considered only at isolated spots where structural integrity needs restoring.
- Concrete patches in the existing asphalt pavement surface should be separated from the overlay with a thin layer of geotextile fabric or other bond breaker.
- Shorter joint spacing in the overlay can help reduce curling and warping stress.
- Joints should be sawed in the overlay as soon as possible because the sawing window may be shorter than it is typically for full-depth pavements.

- The asphalt surface should be sprinkled with water when the surface temperature is greater than 120°F (49°C) during overlay placement.
- No notable asphalt stripping should exist in the asphalt after milling.
- If stripping is severe, the asphalt surface may be milled off and a new interlayer placed between the underlying concrete and the new unbonded overlay (see unbonded overlay over concrete, beginning on page 46).
- Partial bonding between the overlay and the asphalt layer of the existing composite pavement is acceptable and may improve load-carrying capacity.

Overlay Process

The overlay project consists of pavement evaluation, design, construction, and future repairs.

Pavement Evaluation

An evaluation of the existing pavement is necessary to determine whether or not it can provide a uniform platform for the unbonded overlay and, if not, what actions are necessary to obtain that uniformity. In addition, the evaluation determines the existing pavement's structural contribution as a stable platform and key inputs to the overlay design. For general information on pavement evaluation, including specific information about MRDs, see page 13.

Composite pavements are good candidates for unbonded overlays if the existing composite section can provide, or can be cost-effectively repaired to provide, a uniform and stable platform for the overlay. Special consideration should be given to (1) the condition of both

layers of the composite pavement; (2) deterioration of the asphalt surface course (asphalt is a good reflector of problems in the underlying concrete); (3) existing profile grade line (possible evidence of active panel movements); (4) panel tenting, which may indicate the existence of a void under the panel, or joint deterioration of the underlying concrete pavement; and (5) foundation support value.

Overlay Design

Design elements include using the existing pavement as a base, overlay thickness, mixture design, joints, and drainage.

Existing Pavement as Base

In an unbonded overlay design, the existing composite pavement is considered as a stable base and the overlay is designed essentially as a new concrete pavement. The design assumes an unbonded condition between the layers.

There are two approaches to assessing the potential structural contribution of the existing composite pavement to the new pavement system. The approach in the AASHTO Design Guide (1993, 1998) considers the k -value. The M-E PDG (AASHTO 2008) considers both friction and k -value.

Overlay Thickness

Unbonded overlay thicknesses typically range from 4 to 11 in. (100 to 280 mm). The required overlay thickness is affected by the desired load-carrying capacity and service life, as well as the condition of the underlying pavement.

Portions of a project with significantly different existing pavement and subbase conditions may be broken into separate sections and designed to specifically address those given conditions.

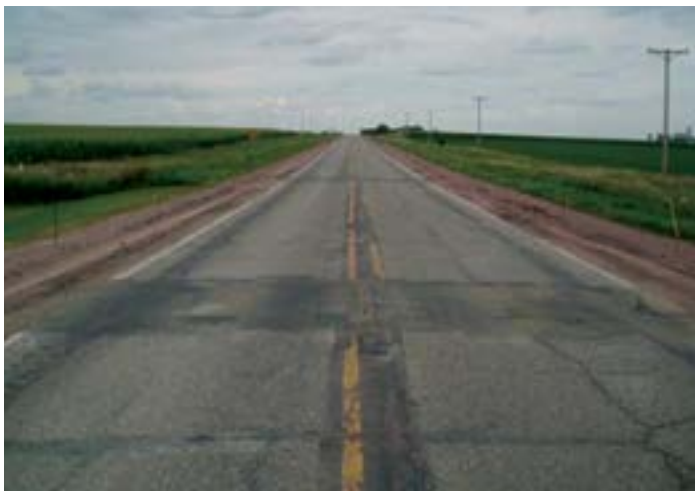

Figure 39. Composite pavement prior to unbonded concrete overlay



Figure 40. Unbonded concrete overlay over composite pavement (source: Todd Hanson, Iowa DOT)

The AASHTO Design Guide (1993, 1998) and M-E PDG (AASHTO 2008) provide design procedures. See basic highlights of and differences among the various procedures in Table 10 in Chapter 4.

Mixture Design

Conventional concrete mixtures are typically used in unbonded overlays of deteriorated composite pavements. When accelerated opening is desired, conventional concrete mixtures should be proportioned for rapid strength gain without increasing shrinkage properties. For additional information on accelerated mixtures, see page 76. Early opening can also be aided by use of maturity measurements.

Joint Design

The load-transfer design is the same as for new concrete pavements. Doweled joints are used for unbonded overlays of pavements that will experience significant truck traffic, typically pavements 7 in. (175 mm) and thicker.

For overlays less than or equal to 6 in. (150 mm) thick, the maximum spacing in feet is 1.5 times the slab thickness in inches.

For overlays greater than 6 in. (150 mm) thick, a maximum joint spacing in feet of 2 times the slab thickness in inches is often recommended for unbonded overlays. A 7-in. (175 mm) overlay would thus receive a maximum 14-ft (4.3-m) joint spacing. The maximum recommended spacing is typically 15 ft (4.6 m).

For situations where the design requires mechanical load transfer across the joints and the pavement is less than 7 inches in thickness, conventional dowels cause slipform paving clearance problems. Smaller diameter dowels do not significantly help the clearance issue and may not provide long-term load transfer because of potential socketing in concrete. One solution that should be considered is the use of structural fibers to help hold cracks and joints together. Additionally, the use of plate dowels provides clearance for the paver and allows for mechanical load transfer. The performance of plate dowels in transverse contraction joints is not well understood in concrete overlay pavements of 5 inches or less. They have, however, been successfully used in industrial parking lots. The effects of exposure of epoxy or galvanized coated plate dowels to deicing salts is also limited. It is recommended that a proven and tested corrosion-resistant surface be required. Research on plate dowels in concrete overlays is being conducted at the MnROAD facility (Burnham and Izevbekhai 2012). See Chapter 4 for additional information on plate dowels.

The use of tiebars for unbonded overlays should follow conventional use for pavements 5 in. (125 mm) thick or more. Using lane tiebars may be appropriate in open-ditch (or shoulder) sections of unbonded overlays if the overlay is 5 in. (125 mm) or greater. In this category, a no. 4 tiebar (0.50 in. [13 mm]) may be appropriate. The use of tiebars in confined curb-and-gutter sections should be considered if the overlay is 6 in. (150 mm) or greater.

Typical joint sealing practices should be followed.

Drainage

During evaluation and design of an unbonded concrete overlay project, existing subgrade drainage should be evaluated, as would be done with asphalt resurfacing. If necessary, steps should be taken to ensure adequate drainage in the future (i.e., retrofit edge drains, free draining shoulder materials, geotextiles, etc.). When underdrains are present, they should be cleaned, video inspected, and repaired as necessary.

Construction

Construction elements may include direct placement, preoverlay repairs, milling, patch preparation, surface cleaning, concrete placement, curing, and joint sawing.

Direct Placement

Direct placement without milling is recommended when rutting in the existing asphalt pavement does not exceed 2 in. (5.0 cm) and there is no significant surface deterioration in the asphalt. Any ruts in the existing pavement are filled with concrete, resulting in a thicker overlay above the ruts; saw-cut depths must be adjusted to maintain a minimum of T/3 where thickness is increased over the ruts.

Preoverlay Repairs

Unbonded overlays generally require only minimal preoverlay repairs of the existing composite pavement. If significantly distressed areas are not shifting and the subgrade/subbase is stable, costly repairs typically are not needed, particularly with an adequately designed overlay; see Table 7.

Note that concrete overlays will bond with any concrete patches on the underlying pavement. Therefore, isolate concrete patches with a geotextile fabric or other bond-breaking material.

Panel tenting (early stages of blowups) may be an indication that there is a void under existing panels. Sections with significant tenting should be repaired to relieve the pressure and provide uniform support before construction of an unbonded overlay.

Milling

If surface distortions in the existing pavement are 2 in. (50 mm) or greater, milling may be considered prior to placing an unbonded overlay. Milling can (1) reduce high spots to help ensure minimum overlay depth, and (2) remove significant surface distortions that contain fractured asphalt material.

Spot milling only significant distortions, typically 1–2 in. (25–50 mm), is often adequate. The objective of milling is not to obtain a perfect cross section, and it is not necessary to completely remove ruts. There is no reason to mill off good asphalt that can help carry traffic loads. If a stripped (loose) layer of asphalt is encountered, it should be completely removed. Matching existing features or minimizing the vertical change in profile grade will often be the primary criteria for determining the milling depth. When this is the case, a thorough evaluation of the thick-

Table 7. Possible Preoverlay Repairs on Existing Composite Pavement in Preparation for Unbonded Overlay

Existing Pavement Condition	Possible Repairs to Consider
Area of subgrade/subbase failure	Remove and replace with stable material (i.e., select borrow, granular subbase, etc.); correct water problems.
Severe distress that results in variation in strength of asphalt	Remove and replace with asphalt material or concrete patch with slurry seal or geotextile separation layer; correct water problems.
Reflective faulting or panel tenting	Full-depth repair with concrete and use asphalt or geotextile separation layer as bond breaker.
Potholes	Fill with asphalt.
Shoving	Mill
Rutting ≥ 2 in. (50 mm)	Mill
Rutting < 2 in. (50 mm)	None or mill
Crack width ≥ maximum coarse aggregate size used in the overly mixture	Fill with asphalt or flowable fill.

ness and condition of the existing asphalt pavement must be performed to assure that the remaining asphalt to be overlaid is sound and thick enough to serve as a subbase and construction platform. If the remaining old asphalt is too brittle or broken up to provide adequate separation, a new separation layer should be constructed. Without an adequate separation layer, working cracks from the underlying concrete could cause reflective cracking of the unbonded overlay.

An adequate layer of asphalt (3 in. [75 mm] minimum) must remain to ensure that the asphalt will function as a uniform subbase for the unbonded overlay structure. Regardless of whether the asphalt will be milled because of vertical constraints or will remain in its existing condition, the minimum thickness of asphalt to be overlaid must be adequate to provide a stable working platform capable of withstanding all anticipated construction traffic (specifically trucks loaded with concrete).

Patch Preparation

If any full-depth concrete patches exist or are placed as part of the project in the underlying pavement, each concrete patch should be isolated to prevent its bonding to the concrete overlay. If bonding occurs, the overlay over the patch will be restrained differently than the rest of the overlay over asphalt, potentially resulting in cracking. To isolate the patch, a geotextile fabric or other bond breaking material, such as an asphalt slurry seal, should be applied to its surface.

Surface Cleaning

Before concrete placement, the asphalt surface should simply be swept. Remaining small particles are not typically considered a problem.

Concrete Placement

When the surface temperature of the asphalt is at or above 120°F (49°C), sprinkling the surface with water can reduce the temperature and minimize the chance of early-age cracking. No standing water should remain on the surface at the time of overlay placement.

Conventional concrete paving practices and procedures are followed for placing, spreading, consolidating, and finishing the concrete overlay. Because of the variation of the thickness of concrete, the concrete material is bid on a volume (cubic-yard) basis. Some states also include a bid item for placement, measured on a square-yard basis.

Curing

Good curing practices are especially critical to thin unbonded overlays because of their high surface-area-to-volume ratio. This is accomplished by applying a curing compound immediately after surface texturing; if the unbonded overlay is 6 in. (150 mm) or thinner, use twice the usual rate of curing compound. The finished product should appear as a uniformly painted solid white sur-

face, with the vertical faces along the edges of the overlay also thoroughly coated.

Joint Sawing

Timely joint sawing is necessary to prevent random cracking. Transverse joints can be sawed with conventional saws to a depth of between $T/4$ (minimum) and $T/3$ (maximum). When there is evidence of some wheel rutting on the existing asphalt pavement, saw-cut depth is of particular concern for unbonded overlays because the distortions in the underlying asphalt pavement can effectively increase the slab thickness; see Figure 41.

Longitudinal joints should be sawed to a depth of $T/3$.

Future Repairs

The recommended repair option for unbonded overlays is the same as for standard concrete pavements.

Key Resources

ACI Committee 325 (2006); ACPA (1998); FHWA (2002a)

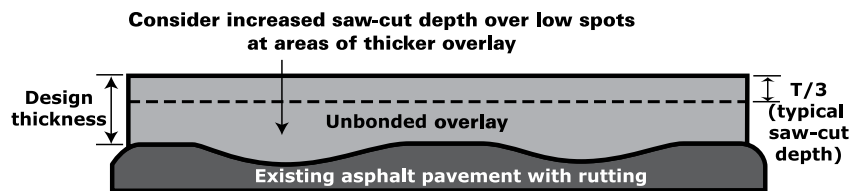

Figure 41. Consider asphalt rut depth when determining saw-cut depth (ACPA 1998)

Unbonded Concrete Overlay on Concrete Pavements

Figure 42 illustrates a concrete pavement that may be a candidate for an unbonded concrete overlay, along with the kinds of preoverlay repairs that may be appropriate.

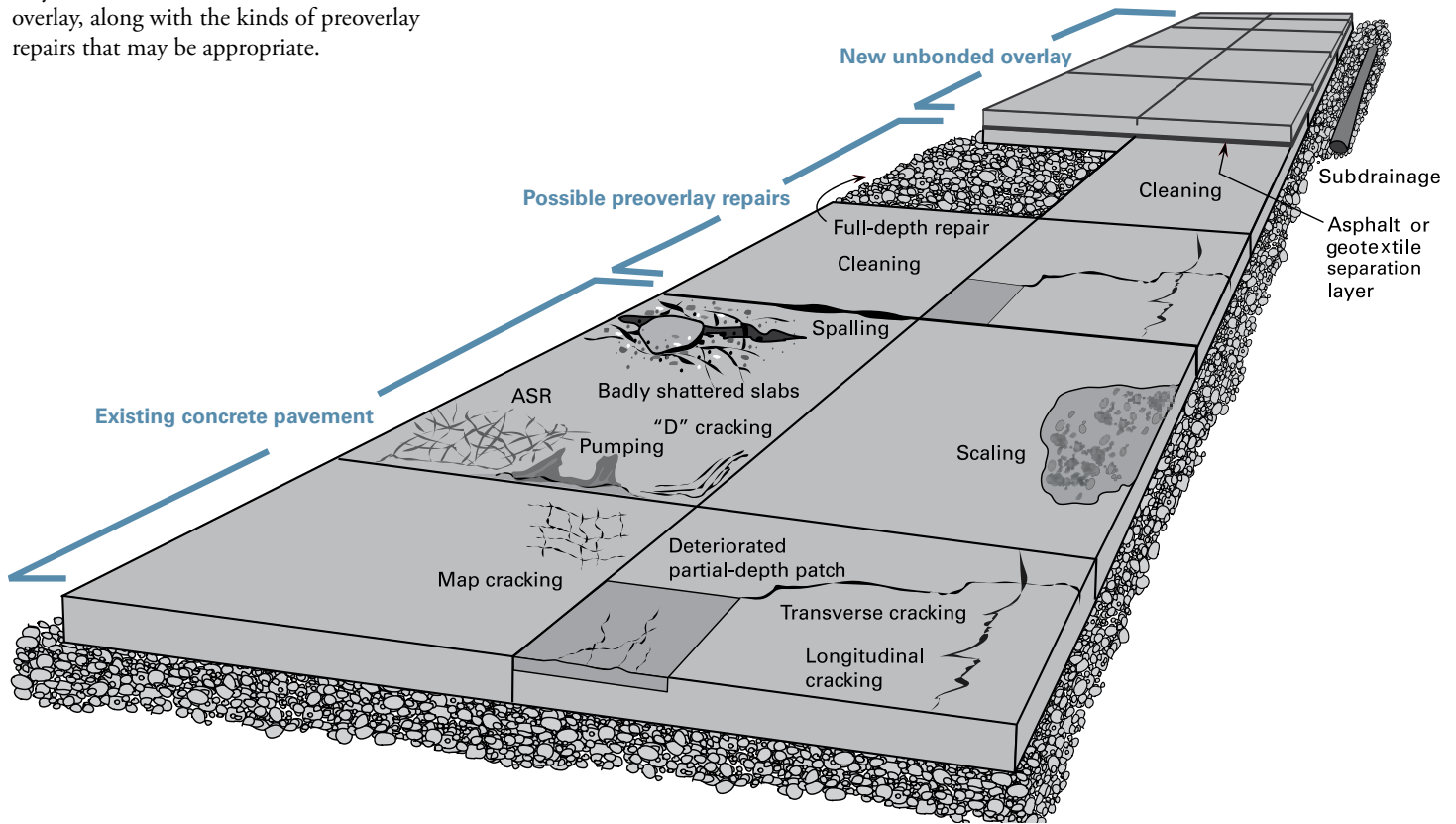

Figure 42. Unbonded concrete overlay of poor condition concrete pavement

Application and Uses

Unbonded concrete overlays on concrete pavements

- May be appropriate for concrete pavements in poor condition, including pavements experiencing MRD, but should be stable and provide uniform support; see Figure 43
- Are generally 4–11 in. (100–280 mm) thick (JPCP or CRCP)
- Are designed essentially as a new concrete pavement on a stable base course (with the existing pavement acting as the stable base), assuming an unbonded condition between the layers
- Restore or enhance the pavement’s structural capacity
- Increase pavement life equivalent to full-depth pavement
- Improve surface friction, noise, and smoothness

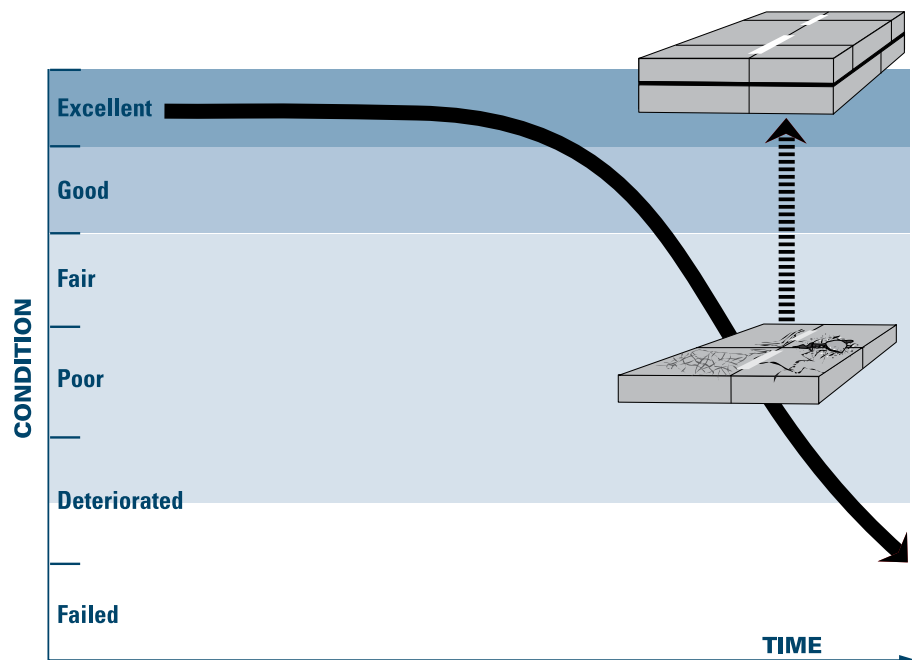

Figure 43. Unbonded concrete on concrete

Performance

Unbonded overlays of concrete pavements have been successfully used in many states, with more than 30 years of good-to-excellent performance; see Figures 44 and 45. Critical factors that affect the performance of unbonded overlays include separation layer design, overlay thickness, joint spacing layout, and load transfer design. Uniform support from the existing pavement is a key factor.

Keys to Success

The following actions will help ensure a successful project:

- Full-depth repairs should be considered only at isolated spots where structural integrity needs restoring.
- A separation layer (typically 1 in. [25 mm] asphalt or geotextile fabric) is required to isolate the overlay from the existing concrete and eliminate reflective cracking.
- Provide a drainable asphalt separation layer to prevent stripping or, in the case of geotextile fabric, daylight the fabric to the foreslope or a drainage conduit.
- The depth of joint faulting should be checked and a determination made whether or not the concrete overlay can eliminate further faulting or other repairs are necessary.
- Joints should be sawed in overlay as soon as possible since the sawing window may be shorter than it typically is.
- Shorter joint spacing in the unbonded overlay, as compared to full-depth pavement, can help reduce curling and warping stress.
- It is not critical to mismatch overlay joints to the underlying joints.

FAQ—Have thinner unbonded overlays actually been constructed?

Yes. Thin, 4 in. [100 mm] thick unbonded overlays are a viable solution for existing concrete pavements that have top-down joint deterioration issues. Project specifics and guidance for designing and constructing this type of unbonded overlays can be found at www.intrans.iastate.edu/research/documents/research-reports/US_18_overlay_construction_web.pdf (Cable 2012).

Overlay Process

The overlay project consists of pavement evaluation, design, construction, and future repairs.

Pavement Evaluation

An evaluation of the existing concrete pavement is necessary to determine whether or not the existing concrete and its subbase can provide uniform support and, if not, what actions are necessary to obtain that uniformity if an unbonded overlay is to be used. The evaluation also determines the existing pavement's structural contribution as a stable base. For general information on pavement evaluation, including specific information about MRDs, see page 13.

For faulted pavements, the cause can usually be attributed to the combination of some loss of load transfer between slabs and some loss of subgrade/subbase support. If the subgrade/subbase is stable, the increase in the carrying capacity of the unbonded overlay has proven to be adequate to overcome faulting. Faulting of 3/8 in. (10 mm) or less in the existing concrete pavement is generally not a concern when the asphalt separation layer is 1 in. (25 mm) or more. When geotextile fabric is used as an interlayer, faulting should not exceed 0.25 in. If geotextile is desired and faulting is an issue, the pavement should be ground to

remove the faulting or an asphalt interlayer should be used. Retrofitted edge drains have been successfully used to reduce the progression of faulting.

Panel tenting (at the joint) may be an indication of bottom-up deterioration. Sections with significant tenting should be repaired to relieve the pressure and provide uniform support before unbonded overlay placement.

Overlay Design

Unbonded overlays are designed similarly to new concrete pavements on a stabilized subbase, assuming a separated condition between the layers.

Overlay Thickness

On heavily trafficked roads, unbonded overlay thicknesses typically range from 6 to 11 in. (150 to 280 mm); on lower-volume roads, they can be as thin as 4 in. (100 mm). The required overlay thickness is affected by the desired load-carrying capacity and service life, as well as the condition of the concrete pavement.

Both the AASHTO Design Guide (1993, 1998) and the M-E PDG (AASHTO 2008) consider the effects of the separation layer. See basic highlights of and differences among the various procedures in Table 10 in Chapter 4.



Figure 44. Route D35 existing pavement in poor condition (source: Todd LaTorella, MO/KS Chapter, ACPA)



Figure 45. Route D35 5-inch unbonded overlay (source: Todd LaTorella, MO/KS Chapter, ACPA)

Separation Layer Design

The separation layer design is one of the primary factors influencing the performance of unbonded overlays on concrete pavements. The separation layer provides a shear plane that helps prevent cracks from reflecting up from the existing pavement into the new overlay. In addition, the separation layer prevents bonding of the new pavement with the existing pavement, so both are free to move independently.

There are three properties that should be considered in the selection and design of the separation layer:

1. Adequate isolation from the underlying pavement to prevent reflective cracking
2. Bedding—the separation layer provides a cushion for the unbonded overlay pavement
3. Drainage—moisture should be able to escape the separation layer

The most common and successful separation layer is a conventional 1 in. (25 mm) well-drained asphalt surface mixture, which provides adequate coverage over irregularities in the existing pavement. The thickness can be slightly increased when irregularities are large enough to impact placement operations. The separation layer does not provide significant structural enhancement. Thus, the placement of an excessively thick layer should be avoided.

Stripping of a dense graded asphalt separation layer has led to premature failure of some unbonded overlays. In locations where water and heavy truck traffic will be present, a drainable asphalt mixture should be used. This can be achieved by reducing the sand content and increasing the volume of 3/8 in. (10 mm) aggregate in the asphalt mixture. See Table 18 on page 78 for information on gradation for asphalt interlayers.

For the last five years, geotextile interlayers have substantially increased in use and geotextiles have proven to be good separation layers. For more information, see Chapter 4, page 59.

Mixture Design

Conventional concrete mixtures are typically used for unbonded overlays of concrete pavements in poor condition. When accelerated opening is desired, conventional concrete

mixtures should be proportioned for rapid strength gain without increasing shrinkage properties. For additional information on accelerated mixtures, see page 76.

Joint Design

Load transfer can be better in unbonded overlays of concrete pavements than in new JPCPs because of the load transfer provided by the underlying pavement. Doweled joints are typically used for unbonded overlays of pavements that will experience significant truck traffic, usually pavements 7 in. (175 mm) and thicker. The load transfer design is the same as for new concrete pavements.

Shorter joint spacing should be used to reduce the risk of early cracking due to increased curling caused by the stiff support provided by the underlying pavement; see Table 8.

For situations where the design requires mechanical load transfer across the joints and the pavement is less than 7 inches in thickness, conventional dowels cause slipform paving clearance problems. Smaller diameter dowels do not significantly help the clearance issue and may not provide long-term load transfer due to potential socketing in concrete. One solution that should be considered is the use of structural fibers to help hold cracks and joints together. Additionally, the use of plate dowels provides clearance for the paver and allows for mechanical load transfer. The performance of plate dowels in transverse contraction joints is not well understood in concrete overlay pavements of 5 inches or less. They have, however, been used successfully in industrial parking lots. The effects of exposure of epoxy or galvanized coated plate dowels to deicing salts is also limited. It is recommended that a proven and tested corrosion-resistant surface be required. Research on plate dowels in concrete overlays is being conducted at the

Table 8. Typical Transverse Joint Spacing

Unbonded Resurfacing Thickness	Maximum Transverse Joint Spacing
≤ 6 in. (125 mm)	6 x 6 ft (1.8 x 1.8 m) panels (not to exceed 1.5 times thickness in inches)
> 6 in.	Spacing in feet = 2 times thickness in inches, not to exceed 15-foot joint spacing

MnROAD facility (Burnham and Izevbakhai 2012). See Chapter 4 for additional information on plate dowels.

The use of tiebars for unbonded overlays should follow conventional use for pavements 5 in. (125 mm) thick or more. Using lane tiebars may be appropriate in open-ditch (or shoulder) sections of unbonded overlays if the overlay is 5 in. (125 mm) or greater. In this category, a no. 4 tiebar (0.50 in. [13 mm]) may be appropriate. The use of tiebars in curb-and-gutter (C/G) sections should be considered if the overlay is 6 in. (150 mm) or greater.

Many states do not intentionally mismatch joints and have not experienced any adverse effects. Some states, however, still intentionally mismatch joints, according to previous guidance, to maximize the benefits of load transfer.

Unbonded plain jointed concrete overlays over continuously reinforced concrete pavement (CRCP) are designed and constructed the same as unbonded overlays on jointed plain concrete pavements (JPCP). Texas has completed many CRCP unbonded overlays over existing CRCP and plain jointed pavements, sometimes increasing the asphalt separation layer thickness to greater than 1 inch.

Drainage

Without good drainage of the separation layer, pore pressure builds up from heavy truck traffic and can cause stripping of the asphalt separation layer. Properly designed, constructed, and maintained edge drains may help reduce pumping, asphalt stripping, faulting, and cracking. Deeper edge drains (subdrains) are used to help stabilize subgrades/subbases. When geotextiles are used as an interlayer, they need to also drain into subdrains or be daylighted at the shoulder.

During evaluation and design of an unbonded concrete overlay project, existing subgrade drainage should be evaluated, as would be done with asphalt resurfacing. If necessary, steps should be taken to ensure adequate drainage in the future (i.e., retrofit edge drains, daylighting free draining subbase materials, geotextiles, etc.).

When underdrains are present, they should be cleaned, video inspected, and repaired as necessary.

Construction

Construction elements may include preoverlay repairs, separation layer, concrete placement, curing, and joint sawing.

Preoverlay Repairs

Typically, only distresses that cause a major loss of structural integrity require repair. If significantly distressed areas are not shifting or moving and the subgrade/subbase is stable, costly repairs typically are not needed, particularly with an adequately designed overlay; see Table 9. As an alternative to numerous repairs, some states increase the unbonded overlay thickness to provide additional load-carrying capacity.

Separation Layer

Use of a sufficient separation layer can help ensure good performance of the unbonded overlay. Before separation layer placement, the existing pavement surface should be

swept clean of any loose material either with a mechanical sweeper or an air blower. Conventional placement practices and procedures should be followed for placing the separation layer (see Chapter 7, page 103).

Concrete Placement

When the surface temperature of the separation layer is at or above 120°F (49°C), sprinkling the surface with water can reduce the temperature and minimize the chance of early-age cracking.

When cooling a black-colored geotextile interlayer, it should be damp and not saturated with water. A simple test is to touch the fabric and no water should show on the fingers. No standing water should remain on the surface at the time the overlay is placed.

Conventional concrete paving procedures are followed for placing, spreading, consolidating, and finishing the unbonded overlay.

Adequately anchoring dowel baskets to the underlying concrete pavement is important. Alternatively, pavers equipped with dowel bar inserters can be used. Because of the variation of the concrete thickness, the concrete material is bid on a volume (cubic-yard) basis. Some states include a bid item for placement, measured on a square-yard basis.

Curing

Good curing practices are especially critical to thin unbonded overlays because of their high surface-area-to-volume ratio. This is accomplished by applying a curing compound immediately after surface texturing; if the unbonded overlay is 6 in. (150 mm) or thinner, use twice the usual rate of curing compound. The finished product should appear as a uniformly painted solid white surface, with the vertical faces along the edges of the overlay also thoroughly coated.

Joint Sawing

Timely joint sawing is necessary to prevent random cracking. Transverse and longitudinal joints should be sawed with conventional saws to a depth of $T/3$. Transverse joint saw-cut depths for early-entry sawing should not be less than 1.25 in. (31 mm). Saw longitudinal joints to a depth of $T/3$.

Future Repairs

The recommended repair options for unbonded overlays are the same as for standard concrete pavements.

Key Resources

ACI Committee 325 (2006); ACPA (1990b); FHWA (2002b)

Table 9. Possible Preoverlay Repairs on Existing Concrete Pavement in Preparation for Unbonded Overlay

Existing Pavement Condition	Possible Repairs to Consider
Faulting; ≤ 0.25 in. for geotextile interlayer; ≤ 0.38 in. for 1-in. asphalt interlayer	None
Faulting; > 0.25 in. for geotextile interlayer; > 0.38 in. for 1-in. asphalt interlayer	Grind pavement to remove faulting for geotextile or thicker asphalt separation layer.
Significant tenting	Full-depth repair
Badly shattered slabs	Full-depth repair
Significant pumping	Full-depth spot repair and drainage improvements
Severe joint spalling	Clean
CRCP with punchouts or other severe damage	Full-depth repair

Chapter 4.

CONCRETE OVERLAY DESIGN

With today's limited highway funding and aging highway network, and given the cost effectiveness of concrete overlays for pavement maintenance and rehabilitation, it is likely that pavement engineers will be designing concrete overlays more often and for a greater variety of existing pavements and pavement conditions. This section provides clear, reliable guidance for designing high-quality concrete overlays and an outline of strategies and resources necessary to implement concrete overlay projects as part of an overall pavement maintenance and rehabilitation program.

The information in this section has been collected from several valuable resources published by the American Concrete Institute (ACI), AASHTO, FHWA, World Road Association, NCHRP, ACPA, Portland Cement Association (PCA), U.S. Army Corps of Engineers, Federal Aviation Administration, and various state departments of transportation. Existing procedures are based on a variety of underlying assumptions and design strategies. It is important for concrete overlay designers to understand the interaction of design with both the selection of mixture materials and the construction process. Perhaps the most critical design principle is that the concrete overlay and the underlying pavement should be viewed as a system.

Concrete Overlay Design Variables

Regardless of the overlay system and design procedure used, the analysis begins with recognition of a number of common inputs to the design process. It is important to first define the scope of the planned project and its intended structural performance requirements. Expected design life will affect both the extent of repairs required on the existing pavement and the design inputs. This in turn influences the thickness, the amount of repair, and thus the cost of the overlay; see Figure 46. The engineer is also required to characterize and understand the existing pavement structure (see information about evaluating the existing pavement in Chapter 2), the anticipated traffic loading, and the materials expected to be used. In most cases, climatic influences play a role, particularly with a bonded concrete overlay system.

FAQ – What if less than 3 inches of asphalt will remain after milling for a bonded concrete overlay of asphalt?

There are two issues to consider. First, the recommendation of having 3 inches of fair-condition asphalt structure recognizes that pavement thicknesses found in the field have an inherent variability—there are thicker sections and thinner sections; thus, the recommendation is a nominal 3 inches. Second, if there is a quality base course or stabilized subgrade below the asphalt, it may be acceptable to have less than the recommended nominal 3 inches of asphalt pavement remaining.

Existing Pavement Characterization

The design and performance of a concrete overlay is affected by the condition of the existing pavement structure. Although both bonded and unbonded overlay systems benefit from the load-transfer capabilities of the existing pavement, bonded overlays are influenced to a greater degree by the underlying pavement condition. Therefore, effective characterization of the existing pavement condition is important in selecting the proper type of concrete overlay to build.

The first step in designing a concrete overlay project is a thorough characterization of the existing pavement. At the very least, the existing pavement section should be verified with cores or historical records. Sometimes, however, the historical records or plans do not represent the actual in-place pavement, so field verification of the records is important. In addition, the existing pavement structure

should be evaluated for its overall current condition, which will influence both the selection of overlay system (bonded or unbonded) and the type, location, and extent of any preoverlay repairs needed.

Surface Considerations

For a bonded overlay to be a practical solution on an existing asphalt surface, a nominal 3 in. (75 mm) minimum of fair-condition existing asphalt pavement structure should remain after any necessary preoverlay repairs and milling. Failure to properly evaluate the thickness and condition of an existing asphalt pavement that will provide structural capacity in a bonded overlay can lead to areas with little or no asphalt remaining after milling. This situation necessitates difficult field engineering decisions, essentially thickening of the concrete overlay to compensate for the reduced structural contribution of the existing asphalt pavement. A thorough evaluation of the existing pavement is necessary to avoid time-consuming and costly delays.

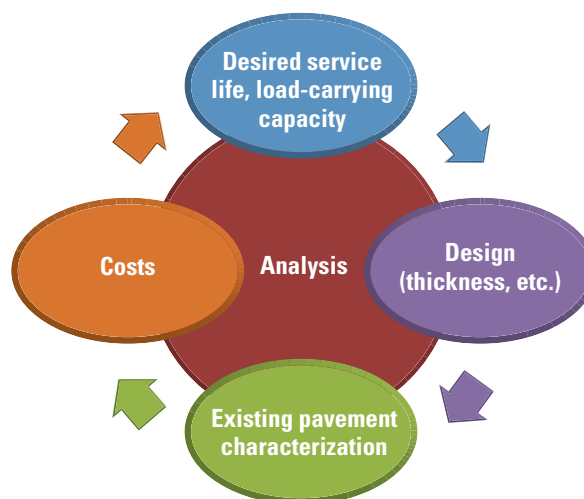

Figure 46. Overlay design factors that affect one another

If the pavement evaluation finds the existing pavement is in poor condition with many localized failures, significant base failures may be indicated. Depending on the potential costs of repairing these failures, a bonded overlay may not be advisable. An unbonded overlay that is less sensitive to the underlying pavement condition may be more cost effective. Condition evaluation permits the pavement engineer to determine the quantity and location of preoverlay repair required.

It should be noted that random cracks in the underlying pavement do not necessarily lead to reduction in service life. Many miles of unbonded concrete overlays have been built that have performed very well with little regard or consideration to repairing the cracking in the underlying platform.

Structural Considerations

For bonded and unbonded overlays of existing asphalt or composite pavements, the layer moduli can be determined through non-destructive testing (see Chapter 2, page 16, Deflection Testing). Cores are recommended for all overlay projects.

When overlaying composite pavements, the condition of the asphalt layer is a good indicator of the existing base support. If the joints and other discontinuities of the underlying concrete are visible and extremely distressed or exhibiting evidence of severe faulting, these should be characterized. Excessive or visibly large deflections under truck loading may require full-depth repair prior to resurfacing.

Regardless of the design procedure used, the designer should also define the degree of support directly beneath the structural layers. In terms of what is defined as a “structural layer” (as opposed to part of the support system), departure from the AASHTO Design Guide (1993, 1998) is becoming increasingly common, particularly in overlays. For example, using the conventional AASHTO Design Guide (1993, 1998) for new concrete pavements, an asphalt layer is considered a support layer. The property defining this support, the k -value, describes the response of the material immediately beneath the concrete pavement. When using the design procedures, it is important to understand at what location in the pavement structure the k -value is being considered. In other approaches to design, principally with concrete overlay of asphalt, the flexural capacity of the asphalt layer is considered a structural component. The specific contribution of the asphalt layer depends on the degree of bond with the concrete. In this case, the k -value would describe the support provided by the materials beneath the asphalt.

FAQ – Do I really need to worry about CTE?

Though the effect of CTE is increasingly being considered in thicker overlays and even new pavements, default values are adequate for the design of unbonded overlays.

Designers are sometimes charged with making decisions based on limited amounts of information. This is particularly true in rehabilitation project designs. Decisions on the design selection should be logical and defensible. The designer should be aware of the impact that selecting the reliability level can have on the final design thickness. In the AASHTO Design Guide (1993, 1998), the reliability level and the overall standard deviation result in an increase in the effective multiplier on the design traffic used in determining the thickness. Appropriate selection of these parameters can build in a predictable level of risk.

Traffic Characterization

To develop a proper pavement design, the anticipated future traffic loading should be known as accurately as reasonably possible. Care must be taken not only to measure or predict current traffic characteristics, but also to assign reasonable growth characteristics.

A prediction of the number of trucks should be made over the design life. Measures sometimes include a prediction of the number of equivalent single-axle loads based on the anticipated traffic distribution. In this case, the designer should not approach traffic estimates with conservative estimates. It is better to make a reasonable estimate and adjust for uncertainty later.

Alternative mechanistic-empirical pavement design procedures use a distribution of traffic loading. This loading describes the number, weight, and geometries of the associated axle loads. Sometimes this is further distributed by the time of day and even the season. Highly sophisticated models include the distribution by lane and the wander of the wheel within the lane. A number of typical distributions available in the M-E PDG (AASHTO 2008) may be adequate for most situations.

At a minimum, average annual daily traffic and percentage of trucks is needed for thickness design. Most of the design software packages have default distribution models for estimating total equivalent single axle loads (ESALs).

Where special traffic generators are present for portions of a concrete overlay project, it may be advisable to adjust the thickness design for discrete portions of the project that experience heavier traffic.

Material Properties

Certain properties of the overlay concrete should be known or estimated prior to the design process (see Chapter 5 for a full discussion of materials used for concrete overlays). This provides the designer additional flexibility to adjust the designs to available material options that can be used to reduce costs without compromising performance.

Strength of the concrete is one of the key design inputs, but this is often misunderstood. The designer should use a strength that is consistent with the assumptions of the design method being used. For example, all AASHTO methods require third-point flexural strength in 28 days, yet it is not uncommon for designers to erroneously use the strength found in the construction specifications. Since this value is often lower, it can result in an unnecessarily thick overlay that drives up cost.

Some methods require an estimate of the modulus of elasticity of the materials. This is often of secondary importance in unbonded overlays and has negligible impact in terms of thickness. This property, however, becomes more important in bonded overlay designs.

Used in sufficient dosages, macro fibers enhance the toughness and ductility of the concrete and may result in reduced concrete thickness for some bonded overlay design procedures (see page 77 and Appendix C for a full discussion of fiber-reinforced concrete).

In some mechanistic-based procedures, the CTE of the concrete is also used. The CTE is a measure of a material's expansion or contraction with temperature; for concrete pavements this has an impact on internal stresses, which may lead to cracks, unless accounted for in the design of proper slab dimensions.

The coefficient of thermal expansion can have a much more significant effect on the performance of bonded overlay designs. In designing bonded concrete overlays for existing concrete pavements, it is important that the CTE of aggregates specified for the concrete overlay mixture design have a similar or lower CTE to that of the existing concrete pavement. This helps ensure that both layers experience similar thermal movements, thus reducing stress on the bond between the two layers. In most cases, using a coarse aggregate

in the overlay concrete mixture with the same mineralogy as that used in the underlying concrete is sufficient.

Climatic Factors

Overlay system performance depends on climatic factors, both during construction and during the service life of the overlay. Relatively thin bonded overlay sections are more susceptible to adverse weather conditions that may affect the ability of the concrete to retain moisture, prevent excessive heat buildup, or prevent freezing. Materials should be selected that are compatible with the anticipated climate and freeze/thaw conditions. Joints and load-transfer systems should be designed to accommodate the movements of the joints due to seasonal changes in pavement temperature. For example, shorter joint spacing may be appropriate.

Curling and warping are also considerations for pavement designers. Slab dimensions and joint layout should be optimized to minimize curling and warping stresses.

Distress Mode

Advancements in computing hardware and the desire to better understand what is occurring as pavements fail has led to newer AASHTO and industry-developed methods that, in essence, break apart the serviceability model into its individual components. Pavement designs are evaluated for “multimodal” deterioration modes that consider one or more of the parameters. Multimodal deterioration models carry a number of advantages. They may aid in forecasting potential maintenance, and they may assist in developing more effective and cost-efficient designs.

Thickness Design Selection

In most cases, the designer will have an idea of the likely feasible alternatives based on the initial survey of the project. In selecting the final thickness design, however, it is important for the engineer to anticipate the condition of the existing section at the time of actual construction of the new concrete surface. In many cases, construction will not begin for at least 2 or 3 years. Some degradation of the existing structure should be anticipated and considered in the analysis. Allowing for this continued degradation in the surface condition, the designer can begin the process of considering feasible design alternatives using the procedures recommended in Table 10.

There are several design procedures available for determining the appropriate thickness of bonded and unbonded concrete overlays. Designers should consult the *Guide to the Design of Concrete Overlays Using Existing Methodologies* (Torres et al. 2012) published by the National Concrete Pavement

Technology Center for current guidance regarding comprehensive thickness design. This document provides guidance for the following design procedures:

- *Bonded Concrete Overlay on Asphalt (BCOA) Thickness Designer* (ACPA 2012) (<http://apps.acpa.org/apps/bcoa.aspx>)
- *Guide for Design of Pavement Structures*, 4th edition (AASHTO 1993) (compatible software at www.acpa.org/WinPAS/) (<https://www.google.com/#q=AASHTO.+1993.+Guide+for+Design+of+Pavement+Structures>)
- *AASHTOWare Pavement ME Design* (AASHTO [no year]) (www.aashtoware.org)

Background of Design Methodologies

Designing either bonded or unbonded concrete overlays is a process that begins with characterizing the existing pavement, defining critical design variables, and then calculating the required overlay thickness. This section presents a general overview of the most common design methodologies:

- *Bonded Concrete Overlay on Asphalt (BCOA) Thickness Designer* (ACPA 2012) (<http://apps.acpa.org/apps/bcoa.aspx>)
- *BCOA ME* (Vandenbossche 2013) (www.engineering.pitt.edu/Vandenbossche/BCOA-ME_DesignGuide/)
- *Guide for Design of Pavement Structures*, 4th ed. (AASHTO 1993) (compatible software at www.acpa.org/WinPAS/) (<https://www.google.com/#q=AASHTO.+1993.+Guide+for+Design+of+Pavement+Structures>)
- *Mechanistic-Empirical Design Guide—A Manual of Practice* (AASHTO 2008) (<https://www.google.com/#q=4.%09AASHTO.+2008.+Mechanistic-Empirical+Design+Guide+%E2%80%93+A+Manual+of+Practice>)
- *StreetPave* (ACPA 2012) (<http://acpa.org/streetpave/>)
- *Optipave V2.0*. (TCPavements 2010) (www.tcpavements.com/index.php?op=0&lang=en)
- *Flowable Fibrous Concrete for Thin Pavement Inlays* (Bordelon and Roesler 2011) (<http://ascelibrary.org/doi/abs/10.1061/41167%28398%2984>) (see Appendix C)
- Illinois DOT’s spreadsheet for bonded concrete inlay/overlay of asphalt design (Roesler et al. 2008) (www.dot.state.il.us/desenv/pdp.html)

In addition, there is an ongoing effort to develop a new methodology for unbonded

concrete overlay designs: Federal Highway Administration Pooled Fund TPF 5-269 *Development of an Improved Design Procedure for Unbonded Concrete Overlays* (under development). Future developments and refinements of concrete overlay thickness design methodologies can be found at www.cptechcenter.org/overlay.

Table 10 provides a summary of the current design procedures, typical input values, and pertinent information. Two of the most important aspects in concrete overlay design are (1) how each method handles the bond between the existing pavement and the concrete overlay, and (2) whether the method assumes the existing pavement will provide significant structural capacity or, alternatively, contribute to the quality of the pavement foundation. With this type of pavement, pavement designers are able to make an informed decision about which method to apply when designing a certain type of concrete overlay.

Note: Table 10 is to be used for general reference purposes only. For design purposes, actual overlay thickness should be determined based on specific design variables for the project, using the appropriate design procedure.

ACPA BCOA Method

The American Concrete Pavement Association (ACPA 1998) developed a mechanistic procedure to design thinner (2 to 4 inch) bonded concrete overlays of asphalt (BCOA) pavements with smaller slab sizes, which are not captured by the two AASHTO methods described earlier. This BCOA method consists of an iterative design process, where the designer evaluates the proposed overlay thickness and joint spacing along with traffic, concrete strength (modulus of rupture), existing asphalt pavement thickness, and composite subgrade/subbase stiffness (k -value). The procedure determines the allowable trucks for the trial design.

The ACPA procedure is based on calculating the fatigue damage in the slab for a corner loading condition, as well as limiting the fatigue damage at the bottom of the existing asphalt pavement at the transverse joint location (ACPA 1998). Temperature curling stresses are also considered in the critical pavement response. One limitation of this method is that it is based on the PCA beam fatigue model, which yields very conservative estimates. As a result, Riley developed a modified ACPA method in 2006 that incorporated a new probabilistic concrete fatigue algorithm. This modified method allows for inputting the existing asphalt pavement properties, accounts for the type and amount of structural fibers, and checks for a potential bond plane failure.

Table 10. Summary of Current Overlay Design Software (developed by Dr. Jeffery R. Roesler, University of Illinois at Urbana-Champaign)

Overlay Type	Typical Design and Software Parameters								
	Traffic (Millions of ESALs)	Typical Concrete Slab Thickness	Maximum Joint Spacing (ft)	Range of Condition of Existing Pavement	Macro-fibers Option (in software)	Transverse Joint Dowel Bars	*Mainline Longitudinal Tie Bars	Recommended Design Procedure	
Bonded Overlays	Bonded Concrete Overlay of Asphalt Pavement	Up to 15	3–6 in.	1.5 times thickness (in.)	Fair to Good	Yes	No	No	1, 2, 8
	Bonded Concrete Overlay of Concrete Pavement	Up to 15	3–6"	Match existing cracks and joints and cut intermediate joints	Fair to Good	Yes	No	No	3, 4, 5
	Bonded Concrete Overlay of Composite Pavement	Up to 15	3–6 in.	1.5 times thickness (in.)	Fair to Good	Yes	No	No	1, 2, 8
	Thin Fibrous Overlays of Asphalt Pavements	Up to 15	2–3 in.	4–6 ft	Fair to Good	Yes	No	No	7
Unbonded Overlays	Unbonded Concrete Overlay of Asphalt Pavement	Up to 100	4–11 in.	Slab < 6 in.—use 1.5 times thickness (in.) Slab ≥ 6 in.—use 2.0 times thickness (in.) Slab > 7 in.—use 15 ft	Deteriorated to Fair	Yes	For slabs > 7 in.	T ≥ 6 in.—use agency standards	3, 4, 5
	Unbonded Concrete Overlay of Concrete Pavement	Up to 100	4–11 in.	Slab < 5 in.—use 6 ft x 6 ft panels Slab 5–7 in.—use 2.0 times thickness (in.) Slab > 7 in.—use 15 ft	Deteriorated to Fair	Yes	For slabs > 7 in.	T ≥ 6 in.—use agency standards	3, 4, 5
	Unbonded Concrete Overlay of Composite Pavement	Up to 100	4–11 in.	Slab < 6 in.—use 1.5 times thickness (in.) Slab ≥ 6 in.—use 2.0 times thickness (in.) Slab > 7 in.—use 15 ft	Deteriorated to Fair	Yes	For slabs > 7 in.	T ≥ 6 in.—use agency standards	3, 4, 5
	Unbonded Short-jointed Concrete Slabs	Up to 100	> 3 in.	4–8 ft	Poor to Fair	Yes	For slabs > 7 in.	For ≥ 3.5 in. slabs at tied concrete shoulders or for T ≥ 6 in.—use agency standards	6

*See additional guidance regarding tiebars for shoulders and widening section beginning on page 71.

Recommended Design Procedures (see previous page for links)

1. Bonded Concrete Overlay on Asphalt (BCOA) Thickness Designer (ACPA 2012)
2. BCOA ME (Vandenbossche 2013)
3. Guide for Design of Pavement Structures. 4th ed. (AASHTO 1993)
4. Mechanistic-Empirical Design Guide—A Manual of Practice (AASHTO 1993)
5. StreetPave (ACPA 2012)
6. Optipave V2.0. (TCPavements 2010)
7. Flowable Fibrous Concrete for Thin Pavement Inlays (Bordelon and Roesler 2011) (see Appendix C)
8. Illinois DOT's spreadsheet for bonded concrete inlay/overlay of asphalt design (Roesler et al. 2008)

In January 2011, the ACPA released a BCOA thickness design web application, *Bonded Concrete Overlay on Asphalt (BCOA) Thickness Designer* (i.e., ACPA BCOA) that incorporates the work by Riley (2006). The ACPA BCOA is valid for a slab thickness of 3 to 6 inches and a maximum panel size of 6 feet. Shorter joint spacings (both transverse and longitudinal) are typically used for bonded overlays over asphalt pavements, such as 4 foot by 4 foot or 6 foot by 6 foot slabs for a 12-foot wide lane. Note that the ACPA BCOA web application does not allow designs outside these ranges and provides warnings to indicate that the trial design needs to be modified or that a bonded overlay of asphalt pavement may not be the appropriate solution. Furthermore, when BCOA designs are approaching 6 inches thick and 6 feet wide, the BCOA-ME procedure described below should be considered.

Updates in 2012 improved the fiber reinforcement input to the ACPA BCOA based on work by Bordelon and Roesler (2012), which used the residual strength ratio of the fiber-reinforced concrete measured according to ASTM C1609-10. In 2012, the ACPA BCOA design tool was also upgraded to allow for structural designs in any climate zone in the United States by including site-specific effective temperature gradients (Vandenbossche et al. 2012) for approximately 200 cities.

The input requirements for the ACPA BCOA thickness design tool follow:

- ESALs
- Percentage of allowable cracked slabs
- Reliability
- Design location (to determine the site-specific effective temperature gradient)
- Existing asphalt pavement
 - Remaining asphalt thickness and modulus
- Composite subgrade/subbase k -value
- Concrete overlay
 - Strength, modulus, fiber residual strength ratio, and CTE
- Proposed slab size and preoverlay surface preparation

The recent implementation of the effective temperature gradient for each city was determined as the equivalent negative temperature gradient that gives the same cumulative damage as the full distribution of temperature differentials for that particular site and inputs (slab thickness, slab length, asphalt thickness, and concrete strength). For all site locations,

this effective temperature gradient occurs 100 percent of the time to give the same fatigue damage as the full temperature differential distribution.

BCOA-ME Method

In 2013, the University of Pittsburgh developed a new design procedure under the FHWA Pooled Fund Study TPF-5(165) (Vandenbossche 2013), the *BCOA-ME*. Since a substantial number of bonded overlays have been in service for an extended period of time, the opportunity existed to reevaluate the modes of failure for these overlays. This is critical since the pioneering procedures that have been traditionally used for the design of bonded concrete overlays are based on the limited amount of information available at the time of their development. The performance review revealed the failure mode is dictated primarily by slab size and not overlay thickness, as was previously assumed.

The *BCOA-ME* procedure incorporates the ACPA BCOA performance prediction model that addresses corner cracks for slab sizes less than or equal to 4.5 feet by 4.5 feet, the Colorado DOT performance prediction model that addresses transverse cracking for slabs with a 12-foot width (Sheehan et al. 2004), and a newly developed performance prediction model that addresses longitudinal cracking in 6-foot by 6-foot slabs. It should be noted that at times diagonal cracks develop in the 6-foot by 6-foot slabs, but these diagonal cracks initiate at the intersection of the wheel path and the transverse joint in the same manner that the longitudinal cracks develop. Instead of propagating to the adjacent transverse joint, as occurs with a longitudinal crack, they veer off toward the lane/shoulder joint and form a diagonal crack. Therefore, the initiation stress for both the longitudinal and diagonal cracks are the same.

The design process also includes a check, based on the work of Vandenbossche and Barman (2010), to determine whether or not there is a potential for reflective cracking. This check does not influence the design thickness but indicates whether or not preemptive measures should be taken prior to replacing the overlay to prevent reflective cracking.

The six primary enhancements to current methodologies provided by the BCOA-ME procedure include the following:

1. The predominant failure modes are redefined as a function of slab size and, unlike in the other procedures, all modes are addressed within this one procedure.
2. The variability of the asphalt stiffness with temperature is considered.

3. The equivalent temperature gradient is defined based on local conditions.
4. The prediction models have been calibrated with actual performance data.
5. The effects of fiber on the performance of the overlay are more accurately quantified.
6. The effects of debonding are considered.

The *BCOA-ME* procedure provides an overlay thickness after the following information is entered into the design spreadsheet:

- Traffic
- Design location
 - Longitude, latitude, and elevation
 - Climatic zone
- Existing HMA pavements
 - Remaining asphalt thickness
 - Approximate percent fatigue cracking
 - Temperature cracking (yes/no)
- Composite subgrade/subbase k -value
- Concrete overlay strength, modulus, fiber residual strength ratio, and CTE
- Proposed slab size

Enhancements (1) thru (4) have been incorporated into the current version of the procedure (Beta Version 1.3) and is available at www.engineering.pitt.edu/Vandenbossche/BCOA-ME/. The design procedure will be finalized, including the incorporation of enhancements 5 and 6, and available for use at the same website.

1993 AASHTO Guide Method

The method found in the 1993 AASHTO Design Guide is based on mathematical models derived from empirical data collected during the American Association of State Highway Officials (AASHTO) Road Test carried out in the late 1950s. Even though no overlay sections were evaluated during the AASHTO Road Test, experience has shown that, when used properly, this procedure provides suitable but conservative bonded and unbonded concrete overlay designs. The AASHTO computer software for implementing the 1993 AASHTO Design Guide is called DARWin. In addition, a number of agencies and state DOTs have developed custom software and spreadsheets to apply this procedure. The ACPA has also developed the WinPAS software package, which implements the procedure.

The 1993 AASHTO Design Guide uses the concepts of structural deficiency and effective structural capacity for evaluating and charac-

terizing the existing pavement to be overlaid. The structural capacity (SC) of a pavement section decreases with traffic and time. In this procedure, SC is expressed in terms of the effective structural number for existing asphalt pavements (SN_{eff}), or the effective slab thickness for concrete pavements (D_{eff}). Figure 47, which is an adaptation of Figure 5.1 in Part III of the 1993 AASHTO Design Guide, illustrates this concept. This figure shows how the structural capacity of an overlay ($SC_{overlay}$) restores the structural capacity of the existing pavement ($SC_{effective}$) to meet the requirements for carrying the predicted future traffic ($SC_{future\ traffic}$).

The 1993 AASHTO Design Guide presents three evaluation methods for determining the effective structural capacity of existing pavements ($SC_{effective}$) when designing concrete overlays: Visual Survey and Materials Testing (Condition Survey), Nondestructive Deflection Testing (NDT), and Fatigue Damage from Traffic (Remaining Life). The designer should select the most feasible method based on the available resources but should recognize that each method yields different estimates.

Even though the Remaining Life method is often used, it is important to note that the 1993 AASHTO Design Guide cites major deficiencies associated with this method and explains that the method is mostly applicable when the existing pavement exhibits very little deterioration. The 1993 AASHTO Design Guide explains that the Remaining Life procedure is based on the AASHTO Road Test equations, and estimating past traffic (in ESALs) may be subjective and/or uncertain. In addition, this method does not account for preoverlay repairs. For these reasons, the designer should use the Condition Survey method or NDT when the structural capacity estimates that result from the Remaining Life method are inconsistent with the observed existing pavement condition.

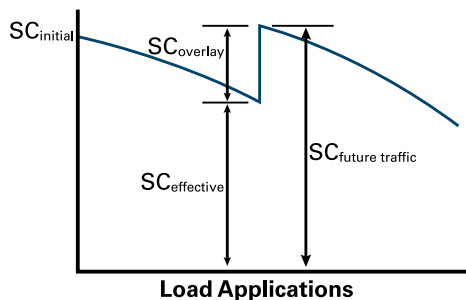

Figure 47. Illustration of structural capacity loss over time and with traffic

AASHTO Pavement ME Design Guide Method

The AASHTO Pavement ME Design Guide procedure was developed under NCHRP Project 1-37A, Development of the 2002 Guide for the Design of New and Rehabilitated Pavement Structures: Phase II (Transportation Research Board 2004), and the original guide and accompanying software were both called the *Mechanistic-Empirical Pavement Design Guide* (M-E PDG). The procedure is implemented in an AASHTO professional software package called *AASHTOWare Pavement ME Design* (AASHTO [no year]) available at www.aashtoware.org.

The AASHTO M-E PDG procedure combines a mechanistic-based approach with field performance data so that an engineer can confidently predict the performance of pavement systems not considered in the original calibration. This method adopts an integrated pavement design approach that allows the designer to determine the overlay thickness based on the interaction between the pavement geometry (slab size, shoulder type, load transfer, steel reinforcement), local climatic factors, and concrete material and support layer properties. The procedure is currently under evaluation and implementation by a number of state DOTs.

Chapter 7 in Part 3 of the M-E PDG (NCHRP 2004), “PCC [Portland Cement Concrete] Rehabilitation Design of Existing Pavements,” contains detailed information regarding the design of bonded and unbonded concrete overlays. This procedure is an iterative design process that involves analyzing a trial overlay design not only in terms of thickness but also in terms of other relevant design features, such as joint dimensions and load transfer, steel reinforcement (if applicable), and concrete material properties. The following list summarizes the AASHTO M-E PDG inputs (NCHRP 2004):

- Rehabilitation type
- Design life
- Pavement failure criteria (cracking, faulting, IRI)
- Reliability
- Traffic
- Local climate
- Pavement cross section and layer properties
- Pavement design features
 - Slab geometry
 - Joint and shoulder type

- Concrete properties (strength, mixture proportions, CTE, etc.)
- Drainage and surface properties

Three input levels are available for pavement design, depending on the quality of the input data. Level 1 inputs are used if project-specific traffic data are available and if certain pavement layer material properties have been measured. Level 2 inputs are used if correlations with standard tests are necessary to complete the design. Level 3 inputs assume national default values in the design process. This document emphasizes Levels 2 and 3 inputs as a recommended starting point for using the AASHTO M-E PDG procedure.

The AASHTO M-E PDG method predicts performance indicators, such as IRI, transverse cracking, and mean joint faulting, over the pavement’s design life for jointed plain concrete overlays. For continuously reinforced concrete overlays, the procedure predicts the mean crack spacing as well as crack width, IRI, and number of punch-outs over the design life. For all of the distress predictions, the AASHTO M-E PDG method calculates incremental damage over the life of the pavement by employing transfer functions for the specific distresses, which are linked with the corresponding maximum pavement response (deflection or tensile stress).

ACPA StreetPave Method

In 2012, the ACPA released a new version of StreetPave that includes bonded and unbonded overlay designs for existing concrete, asphalt, and composite pavements. This software utilizes new engineering analyses to produce optimized designs for city, municipal, county, and state roadways. For existing concrete pavements and overlays, StreetPave 12 may be used to estimate service life and/or failure criteria.

StreetPave 12 also offers an asphalt cross section design process (based on the Asphalt Institute method) to create an equivalent to asphalt design for the load-carrying capacity requirement. A “Life Cycle Cost Analysis” module allows you to perform a detailed cost/benefit analysis and make informed decisions on your pavement design project. With one pavement design tool, you can design equivalent concrete and asphalt sections and evaluate the best possible solution(s) for your pavement needs.

Bonded concrete overlays on asphalt or composite are designed using the same equations as the ACPA BCOA method. All other concrete overlay design methods in StreetPave use the same overlay design equations as the 1993 AASHTO Design Guide method. This

includes using the same equations and factors for determining the D_{eff} for existing concrete pavements and the same overlay thickness determination equations (e.g., $D_{\text{OL}} = D_f - D_{\text{eff}}$ for a bonded concrete overlay on concrete). The only differentiating factor between StreetPave and the 1993 AASHTO Design Guide overlay designs is that the required composite thickness (D_f) is calculated using StreetPave's core design equations, using faulting and cracking as the failure criteria. StreetPave also provides functionality to include fibers in any design.

Slabs with Optimized Geometry and OptiPave2™ Design Software

A new methodology called TCP (thin concrete pavements) or short-jointed concrete slabs has been developed to design the concrete slab thickness by optimizing the slab size given the geometry of the truck axles (Covarrubias and Covarrubias 2008). The key principle of the design method is to select the slab size so that not more than one set of wheels is on any given slab at one time, thereby minimizing the critical top tensile stress. Full-scale test sections were constructed and tested at the University of Illinois under accelerated pavement loading conditions with a slab thickness of 3.5 to 8 inches on either aggregate or asphalt base layer (Cervantes and Roesler 2009; Roesler et al. 2013). The performance data from the full-scale test were utilized in the development of the mechanistic-empirical design software called *OptiPave2™* (Covarrubias et al. 2010; Covarrubias 2011). *OptiPave2™* software is specifically tailored to design short-jointed concrete pavements for any set of climate, traffic, subgrade/subbase layer, and material property inputs, including the addition of macro fibers.

Thin concrete pavements designs include unbonded concrete pavement over granular or stabilized base layers. Typical slab sizes for TCP are between 4.5 feet and 8 feet long by 6 feet wide with slab thickness ranging from 2.4 to 10 inches depending on traffic, climate, and soil conditions. The *OptiPave2™* design software predicts the level of cracking, faulting, and IRI for a given set of inputs. *OptiPave2™* is currently the only pavement design software that is able to optimize the slab thickness requirements for slab sizes less than 10 feet. Since 2006, multiple projects have been constructed in Latin America, including Chile, Peru, and Guatemala. *OptiPave2™* software licenses are available in North America from PNA Construction Technologies, Inc. (www.pna-inc.com, telephone number 800-542-0214).

FAQ – How is the thickness of an asphalt surface in a composite handled?

In this approach, the same failure model is used, but the assumption is made that the asphalt layer has the maximum permitted thickness of 6 in. (150 mm), which corresponds to the limits of the current design model. The elastic properties of the asphalt surface are used in the model.

Design Considerations for Bonded Overlay Systems

With bonded concrete overlays, the bond between the overlay and the underlying pavement assists the horizontal shear transfer at the bond plane. This horizontal shear transfer stresses into the underlying layers, thereby decreasing tensile stresses in the bonded overlay. Somewhat different considerations are required depending on whether the overlay is bonded to existing concrete or to existing asphalt. All bonded concrete overlay systems, however, depend on the integrity of the underlying pavement.

Bonded Overlays of Asphalt and Composite Pavements

A unique design consideration for bonded overlays on asphalt or composite pavements is the joint spacing to mitigate curling and warping stresses in the bonded overlay. The ACPA's original 1998 design procedure for this overlay type was based on a single mode of failure—the corner break. The ACPA's 2004 revised procedures incorporated probabilistic methods into concrete fatigue models, but the procedure for this overlay type continued to be based only on the corner break mode of failure.

The corner break model has worked adequately. In recent years, however, it has been recognized that the two most common precursors to failure for bonded concrete overlays on asphalt or composite pavements are delamination stemming from failure in the bond plane or from failure in the underlying asphalt layer. Therefore, the most recent revisions of the design procedure for this type of overlay reflect a “weakest link” approach, applying probabilistic techniques to all three modes of failure.

First, design parameters are input into the design model. Then stresses are calculated using the corner stress model. From that information, strains in the bottom and top of the asphalt layer, plus horizontal stresses inferred at the bond plane, are calculated based on the location of the composite neutral axis.

Concrete corner stresses are then compared against the ACPA's 2004 fatigue model for concrete. Strains in the asphalt are compared to Asphalt Institute design fatigue models. Bond plane stresses are evaluated using a horizontal shear data model based on data obtained from Iowa, Florida, and Colorado projects. The calculated stresses and strains for each mode are then compared against the probabilistic models of each mode to determine which factor is the most likely mode of failure, or the weakest link, driving failure in the overall system.

The bottom line is that understanding the interaction between bond plane stresses and corner break stresses helps designers optimize joint spacing and several other factors in designs for bonded concrete overlays on asphalt pavements.

In addition to the probabilistic adaptation of the mechanistic procedures, new advancements in materials were included, particularly with regard to the inclusion of fibers. The effect of fibers in the models is based on their ability to enhance the fatigue resistance of the concrete. The design procedure for fibers is open ended in that as new fibers are developed and properties are established, these can be incorporated accordingly.

Probably one of the more challenging aspects in the design of bonded overlays of asphalt and composite pavements is the consideration of the supporting platform. For designs of this type, the classic k -value described earlier is based on the value at the bottom of the asphalt layer rather than at the bottom of the concrete layer.

The joint design of thin bonded overlays over asphalt pavement is a distinguishing characteristic when these projects are placed in the field. The transverse and longitudinal joint spacings are always 6 ft (1.8 m) or less in length as determined by the design analysis. It is important that joints in this type of overlay be cut as quickly as possible to minimize the likelihood of curling stresses developing, triggering delamination at the edge of the pavement. Early-entry saws are often used.

There are numerous examples of bonded overlays of asphalt and composite pavements that are approaching 20 years of service. When properly designed and constructed, these concrete overlays can perform satisfactorily for any desired design life.

Bonded Overlays of Concrete Pavements

The AASHTO Design Guide (1993, 1998) procedure for bonded overlays of concrete pavements uses a “design deficiency” or “remaining life” approach. The mode of failure most commonly used is serviceability. This is largely due to the fact that most pavement engineers today are comfortable with the concept. The existing pavements in these cases have not failed. It is assumed, however, that some of the pavement life has been consumed in either fatigue or serviceability, depending on the design procedure being used.

First, standard design methods (see existing methodologies) are used to determine the required thickness of a new pavement based on the anticipated traffic, planned materials to be used, and other parameters typically considered in new pavement design. Having determined the overall required pavement thickness, the pavement thickness equivalent after adjusting for the life consumed of the existing section is estimated. This thickness corresponds to the thickness required to carry the number of loadings to failure as defined by AASHTO. In the AASHTO Design Guide (1993, 1998) and earlier terminology, this is simply the change in serviceability and corresponds to the “remaining life.”

Additional minor adjustments may also be made having to do with observations of existing pavement condition, but these are somewhat subjective. After the adjustments, the resulting number represents how much effective pavement thickness is still actually available to be further “consumed” or used in the new pavement system in addition to the new overlay. The difference in the thickness calculated for a new pavement and this effective section is the “design deficiency” or the required thickness of the new section that should be bonded to the existing pavement. For further information, see the AASHTO Design Guide (1993, 1998).

Critical to the performance of this type of overlay is the development of a bond between the two layers. Existing design procedures for bonded overlays do not specifically address bond strength, treating it primarily as a construction issue. If the section is cleaned and constructed correctly and proper curing procedures are used, bond strength is usually not a problem. Extreme daytime to nighttime temperature swings, however, can sometimes trigger delamination failures. If ambient temperature differentials in excess of 30°F are anticipated, from the time pavement is set and for the next 12 to 18 hours the section should be protected.

FAQ—What is serviceability?

Serviceability or present serviceability rating (PSR) was developed during the AASHTO Road Test. The PSR is defined as “the judgment of an observer as to the current ability of a pavement to serve the traffic it is meant to serve” (AASHTO 1962). The PSR scale ranges from 0 (very poor) to 5 (very good).

Maintaining the bond is especially critical during the first few days when the overlay is susceptible to curling and warping stresses, especially at the pavement edges. Therefore, the bond must be protected through thorough proper curing practices, particularly of the pavement edge, minimizing relative humidity and temperature differentials between the two layers and keeping early traffic away from the pavement edges until adequate bond strength has been achieved (usually when opening strength has been achieved).

Joints in designs of this type must be matched to the existing section. Transverse joints should be cut full depth of the overlay plus 0.50 in. (13 mm) and must be as wide as or greater than the crack below the joint in the underlying pavement; see Figure 48. Note that this is different from the width of the existing joint reservoir. Longitudinal joints should be cut at least $T/2$.

Designs for overlays of existing CRCPs are also possible. In the case of CRCPs, however, there is no need to match the transverse joints since none exist, with the exception of terminal joints and full-depth repairs.

The use of steel reinforcement or dowels is not usually a consideration for bonded overlays on concrete pavements unless the overlay is thicker than usual, new shoulders are being tied, or there is also a desire to retrofit load transfer.

Properly built, bonded overlays can reasonably be expected to provide a minimum service life of 15 years before maintenance is required. The first indication of problems on these overlay projects is usually early delamination at the bond plane, quickly fol-

lowed by classic fatigue failure at isolated joint locations. These can be repaired using partial-depth repair techniques if the underlying slab remains sound.

Design Considerations for Unbonded Overlay Systems

Unbonded overlay designs usually do not consider bond, though in fact some bonding usually occurs and is beneficial. They are essentially designed as new concrete pavements, with the pavement being overlaid acting as a base. Adaptation of existing design procedures is relatively straightforward and construction relatively easy. Unbonded overlays are usually designed to serve 20 to 30 years.

The selection of the load transfer coefficient in the AASHTO procedure should be made with recognition of the character of the underlying layer in addition to the intended load transfer system for the overlay. Consideration should be given to the underlying structure providing additional load transfer, which is not necessarily true of new concrete pavements. The designer should not arbitrarily pick a “conservative” value, as this is not the intent of the design procedure. The ACPA’s *WinPAS* software program (based on AASHTO Design Guide 1993) includes an entire section for use in designing these types of systems.

Care must be exercised during construction to ensure that the saw depth of the unbonded overlay is adequate, particularly when the overlay thickness varies, such as in variable cross slope, transitions, etc.

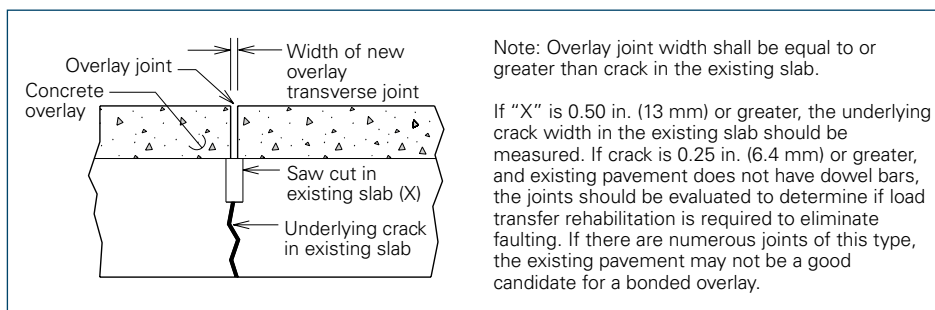

Figure 48. Width of overlay joint saw cut must be greater than the crack width in the existing pavement

FAQ—What happens if an unbonded overlay bonds to the separation layer?

Beneficial bonding can occur when an asphalt separation layer is used as part of an unbonded overlay design. Although not factored in the thickness design procedure, this beneficial bonding effectively increases the load-carrying capacity of the unbonded overlay system. This is one reason that rubblization or crack and seat methods are not recommended preoverlay activities. Leaving the existing pavement intact preserves the structural integrity of the existing pavement and maximizes the value of the investment placed in the original pavement.

FAQ—Why is it better to use concrete as the material for making grade corrections?

There are many reasons to use a nominal thickness asphalt separation layer while making grade corrections with concrete:

- The cost of the two materials on a volume basis is very similar.
- When a cubic-yard pay item is used for the concrete overlay, the risk of yield loss to the contractor is nil; thus, the agency pays only for the actual quantity of material used.
- It is very difficult to place variable thickness asphalt layers to true grade because of variable roll down; there will still be significant thickness variation when this approach is used.
- With cost being nearly equivalent, an increased thickness of concrete will add significantly more life than a thicker asphalt separation layer.
- When dowel baskets are used in the concrete overlay, securely anchoring them into a variable thickness asphalt separation layer has proven to be difficult.

Unbonded Overlays of Concrete Pavements

In many cases, an existing concrete pavement—even one in poor condition—can provide a cost-effective base for a new concrete overlay.

Suitability of Existing Pavement as a Base

The existing pavement is suitable as a base for an unbonded overlay if it can meet the desired design life requirements for the base. The existing pavement must be stable and uniform; that is, it must not experience significant differential movement and there should not be large areas lacking adequate structural support.

When an entire concrete pavement has begun to break up, it is a good indicator of serious subgrade/subbase problems that need to be addressed before other solutions are considered. If the subgrade is unstable, it may be time to replace the pavement and correct the subgrade/subbase.

Isolated areas of full-depth structural distress are generally not a problem if they can be repaired cost effectively before placing the overlay. On the other hand, areas of MRD that cause movement from expansion and/or contraction in the existing pavement require careful evaluation.

If MRD-related movement is limited primarily to the joints (e.g., D-cracking movement), and if full-depth joint repairs can be justified from a cost perspective, a pavement may still be a good candidate for an unbonded concrete overlay. Unbonded concrete overlays on concrete pavements with full-depth structural and/or joint repairs have proven performance records as effective bases for unbonded concrete overlays. Some agencies have even had success with infilling deteriorated joints with stable material such as flowable mortar.

When an entire concrete pavement has deteriorated severely along the length of the pavement due to movement, it is probably time to reconstruct the entire pavement. A good option is to recycle the pavement in place and use it as an unstabilized (granular) subbase for a new, full-depth pavement if the existing subgrade is adequate (see Appendix B for a discussion of recycling options).

Interlayer

All unbonded concrete overlays on concrete must be separated from the existing concrete pavement by a stress-relief layer, or interlayer, to prevent reflective cracking from movement of the existing pavement. Interlayers serve multiple purposes:

- The interlayer provides a shear plane that relieves stress and helps prevent cracks from reflecting up from the existing pavement into the new overlay.
- The interlayer may prevent bonding of the new pavement with the existing pavement, so both are free to move independently.
- Drainage must channel infiltrating water along the cross slope to the pavement edge and then be outletted.
- Bedding is a cushion for the overlay to prevent keying from existing faulting.

The design should consider the relative importance of each purpose based on project-specific conditions and the condition of the existing pavement.

Over the years, many stress-relief methods have been used successfully. The most common stress relief is a thin layer of asphalt material. Thickness is not critical, but 1 in. (25 mm) is usually adequate to eliminate potential problems with “keying” of faulted slabs (see Figure 49), localized repairs, etc. When constructing CRCP unbonded overlays over both CRCP and plain jointed pave-

ments, Texas has sometimes increased the asphalt separation layer thickness to greater than 1 in. (25 mm).

It is important not to use the asphalt separation layer as a leveling course. All grade corrections, including leveling, should be accomplished with the concrete overlay itself.

The geotextile should be either daylighted past the edge of the shoulders or tied into a longitudinal underdrain system to provide positive drainage. Laps should be a minimum of 8 inches, and the geotextile should be anchored securely using nails and washers at 6 feet c/c each direction. The structural condition of the existing concrete pavement must be carefully assessed before selecting a geotextile instead of an asphalt interlayer.

There has been one documented case where noise from concrete slabs rocking against each other was observed. This project was a 4-inch thick unbonded overlay placed on a relatively thick (3 mm+) geotextile. No formal studies were performed on the project, but based on informal observations, the general hypothesis

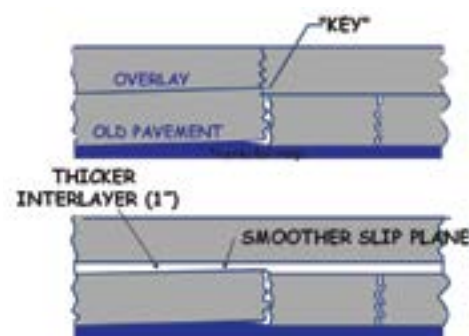

Figure 49. Upper sketch shows concrete overlay locking up with old pavement (keying), and lower sketch shows interlayer separates overlay from existing pavement.

is that the compression of the fabric under traffic loading allowed deflection of the slabs, which caused the noise. The noise was less prevalent during warmer temperatures when the slabs were tight against each other and eventually subsided completely. In 2013, the Minnesota DOT started testing the different thicknesses of nonwoven geotextile fabric under 3 -inch thick (fiber-reinforced) unbonded concrete overlay over concrete. The test sections were at Minnesota DOT’s pavement test track, MnROAD, and the final results will be available in 2014. Early observations indicate a difference in both physical and audible behavior of the overlays for the different fabric thicknesses.

Interlayer fabric is specified by weight and thickness (mils) and color; see Figures 50 and 51. Table 11 provides a general rule of thumb for weight and thickness. The weight per square yard and thickness should be given when specifying a geotextile separation layer. See Chapter 5, Separation Layer Materials, for additional details.

If joint faulting in excess of 3/8 inch for asphalt interlayer and 0.25 inch for geotextile interlayer is present, the joints should be milled to eliminate the vertical offset or an asphalt separation layer should be used.

For unbonded overlays of concrete pavements, some agencies note the underlying pavement joint locations and intentionally place the joints in the new overlay away from those joints such that they are mismatched. The rationale for this is that load transfer will be improved. Other agencies discount this idea in favor of a more construction-friendly approach. In this case, joints are simply placed where they would normally be according to the type of design being built. Both strategies have resulted in good performance. An exception to this is existing expansion joints, which must be matched in the unbonded overlay; see Figure 52.

Drainage of Interlayer

The presence of water within the interlayer system will often accelerate the development of distress in the overlay. Water can enter a pavement system from the top down or from the bottom up due to any of the following situations:

- Longitudinal joint trapping
- Tight, clay subgrade that does not drain
- Densely graded subbase that does not drain
- High water table capillary action
- No subdrains, or subdrains are not working

All else being equal, improvements to pavement drainage can ultimately allow for a thinner overlay design. Such improvements have the additional benefit of facilitating the egress of water from the pavement system, which is often a key factor in the joint deterioration being mitigated by the overlay.

For example, a change in profile and/or cross slope can be designed in the overlay so that water is more readily shed from the pavement surface. Joints in the overlay can be designed to resist excessive ingress of water. This can be done by constructing them with a narrow (single) saw cut and/or filling or sealing them appropriately. Subdrainage can also be improved if measures are taken to retrofit edge drains.

For an unbonded overlay, either a nonwoven geotextile that meets certain transmissivity requirements (see Table 11) or open-graded hot-mix asphalt (HMA) can be used as an interlayer that promotes drainage, provided there is an outlet. Nonwoven geotextile interlayers do promote drainage (wicks water) but must also have a proper drainage outlet. See miscellaneous details for drainage outlets beginning on page 72.



Figure 50. Geotextile fabric separation layer (source: Missouri DOT)



Figure 51. White geotextile fabric separation layer (source: Larry Engbrecht, South Dakota ACPA)

Table 11. Typical Weight and Thickness for Geotextile Interlayer

Interlayer Fabric		
≤ 4-in. overlay—consider 13 oz/ yd ² typical thickness, 130 mils	≥ 5-in. overlay—consider 15 oz/ yd ² typical thickness, 170 mils	Weather resistance > 60%
2kPa—120–150 mils	2kPa—155–185 mils	Test tensile strength after 500 hours of UV accelerator
20kPa—80–110 mils	20kPa—110–140 mils	Tensile strength after test must be at least 60% of initial strength
200kPa—20–50 mils	200kPa—40–70 mils	



Figure 52. Overlay blowup where expansion joint should have been cut over existing concrete expansion joint (source: Dan DeGraaf, Michigan Concrete Paving Association)

Asphalt interlayers have served as separation layers on concrete for many years. Occasional problems, however, have been noted with asphalt stripping within the interlayer under repetitive loading, causing a loss of support for the unbonded overlay; see Figure 53. This can occur occasionally with high truck-traffic volumes in the presence of water in the interlayer. Usually, the stripping takes several years to develop. The best preventive solutions are the following:

- Provide positive drainage for the asphalt layer. Under heavy truck-traffic loading, consider using a drainable asphalt mixture or the gradation used by the Michigan DOT (see Chapter 5, page 78, Table 18). The interlayer should be daylighted to the edge of the shoulders or a subdrain system installed.
- Incorporate antistripping additives such as lime in the asphalt. Lime was found to be more effective than liquid antistripping additives.
- Seal joints in the concrete overlay and at the shoulders.
- Utilize a geotextile separation layer with positive drainage.



Figure 53. Asphalt stripping of interlayer (source: Dan DeGraaf, Michigan Concrete Paving Association)

Joint Design

Because of the high stiffness of the underlying platform (the existing concrete pavement) in unbonded overlays on concrete, it is necessary to shorten joint spacing in the overlay compared with normal designs. The shorter joint spacing is necessary to reduce the risk of early cracking due to temperature curling and moisture warping stresses, combined with loading stresses. Note that existing AASHTO methods do not consider this in design.

Rule-of-thumb guidance for joint spacing for unbonded overlays using these methods is based largely on experience (see Table 21, beginning on page 99, for information about maximum joint spacings).

Transverse joints in the unbonded overlays can be plain, doweled or, in a continuous reinforced concrete overlay, totally eliminated. Plain undoweled joints are the most common for thicknesses less than 7 inches. There are conditions, however, when mechanical load transfer is required to meet load criteria with certain thickness restrictions due to costs or vertical limits. Before dowels are used, consideration should be given to shorter joint spacing using synthetic fibers that help hold the joints tight. If that is not possible, then rounded or plate dowels can be considered. Thin unbonded concrete overlays (less than 5 in. [125 mm] thick) have been built under appropriate loading conditions using short joint spacing, usually 6 ft (1.8 m) or less, and do not have dowels.

The purpose of the dowels in transverse joints is to help load transfer across the transverse joint. Dowels are typically used when heavy truck traffic is anticipated, which normally drives the design thickness to 7 in. (175 mm) or greater. The depth of the dowels is at $T/2$ except in super transition areas (see miscellaneous design details for further information in supers). The transverse saw cut depth over dowels is $T/3$ or $T/4$.

There are constructibility issues (mainly paving machine clearance to the rounded dowel) when using load-transfer dowels in thin overlays (< 7 inches) that necessitate using smaller-diameter dowels (1 inch or less) when dowels are needed. The use of smaller-diameter dowels has a reduced bearing area that increases the bearing stress on the smaller concrete area under the dowel bar, sometimes resulting in premature socketing (enlargement of the area around the dowel), which defeats the purpose of using dowels. In response to the need to accommodate thinner pavements and yet meet design loading for longer joint spacings, the concrete paving industry is beginning to utilize plate dowels, particularly in industrial parking lots; see Figure 54. The plate dowels solve paving machine clearance problems and provide the load transfer across the joint. Because of the larger horizontal surface area of plate dowels versus round dowels, the bearing pressure (psi) on the concrete is reduced. The reduced restraint and stresses of plate dowels also minimizes random cracking in thinner sections. To date, there is a limited number of plate dowels used in highway projects. In cases where thin unbonded overlays are desired to meet vertical restrictions and load demands, however, the use of synthetic fibers for shorter contraction joints in combination with plate dowels in construction joints does have merit.

Manufacturers offer various plate dowel geometries and associated installation devices. The shrinkage restraint is reduced by using a tapered shape or formed void or by having compressible materials on the vertical faces with a thin bond breaker on the top and bottom dowel surfaces, per ACI 360R-10. The tapered shape, along with a thin bond breaker on all sides, allows a void space to develop along the vertical sides of the dowel, eliminating restraint as the slab shrinks from the joint; see Figure 55. Compared to round dowels, plate dowels allow adjacent panels to move



Figure 54. Tapered plate dowel baskets in transverse contraction joints and football-shaped plate dowels for slipformed longitudinal construction joints

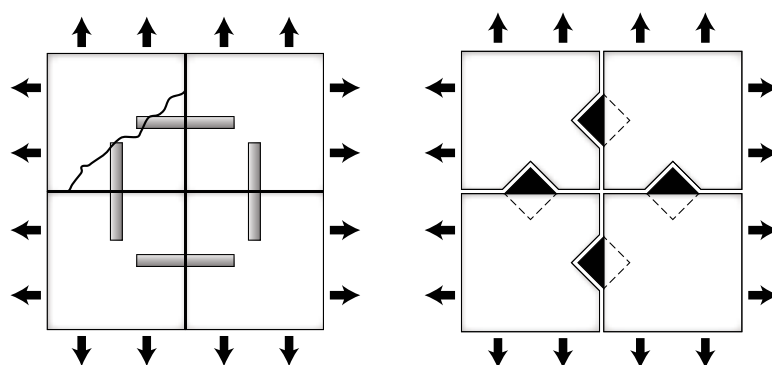

Figure 55. Higher shrinkage restraint in joint intersection with round dowel (left) versus joint intersection with plate dowel (right)

freely without restraint and can therefore be placed within 6 inches of a joint intersection where curling and warping stresses are the greatest. Similarly, a formed void or compressible material can also eliminate restraint as the slab shrinks from the joint.

Because of the various plate dowel geometries and installation devices available, the individual manufacturers' published engineering reports should be consulted to determine optimum dowel size and spacing for a specific project. Plate load-transfer devices are also useful in other pavement applications where joints should have load-transfer capability while allowing two-directional doweling and odd-shaped panels; see ACI 302-1R-04 (ACI 2010). The use of plate dowels exposed to deicing salts is limited. It is recommended that a proven and tested corrosion-resistant surface be applied to these dowels when exposed to deicing. See Miscellaneous Design Details for further discussion on plate dowels.

Unbonded Overlays of Asphalt Pavements

Unbonded overlays of asphalt pavements can address existing sections that have crown or ruts in the surface. Placing the concrete directly on the surface positions the thickest concrete at the points of highest load in the pavement structure and is therefore one of the more efficient designs. If rutting is extreme (greater than 2 in. [50 mm]) or the change in cross section due to crown is significant, care should be taken to ensure that the design plans call for adjusting the sawed joint depth accordingly.

Due to the variability in thickness across the section if placed directly on the asphalt, the contract documents should include provisions for payment for materials separately from payment for placement. These so called "square-yard cubic-yard" provisions are recommended for all concrete overlay projects and are important in reducing the contractors' risk and owners' cost in bidding the projects.

Unbonded Overlays of Composite Pavements

Unbonded overlays of composite pavements follow the same design guidelines as concrete overlays of concrete pavements. The primary difference is that the separation layer already exists in the form of the asphalt layer of the composite pavement. In some cases, the existing asphalt may be unsuitable as a separation layer and must be milled off and a new separation layer placed. This primarily occurs when the asphalt is prone to lose stability (resulting in a loss of support for the overlay) due to stripping.

Plan Development

For DOTs that are inexperienced with the design of concrete overlays, the approach should be similar to that of designing an asphalt overlay. There is no need to add complexity to the planning and engineering process simply because the overlay type has changed. The location, geometrics, and maintenance of traffic requirements should dictate the level of design detail that is required in the plans.

For decades, rural asphalt overlay projects have been successfully designed and built from a set of plans consisting of a title page, typical section(s), pay quantities, notes, plan view sheets, and standard drawings. This approach is entirely acceptable for a concrete overlay under the same conditions. That being said, for projects in urban or suburban locations, especially where vertical (bridge clearance, drainage inlets, etc.) and horizontal (barrier wall, curb, etc.) constraints are present, the plans must include the appropriate details and information to communicate how the concrete overlay will be treated to meet these conditions.

An example index of plans for a rural concrete overlay on a state route or county road would include the following:

- Title sheet with location map
- Typical sections—note limits of any correction of superelevation
- Estimated quantities and pay-item notes
- Summary of quantity estimates
 - Preoverlay repairs
 - Subdrain installation
 - Pavement removal
 - Separation layer (if used)
 - Concrete overlay—cubic yard and square yard
 - Shoulders
 - Erosion control—temporary and permanent
- Survey information in tabular format—control points, curve data, existing pavement elevations, and proposed concrete overlay elevations
- Sequence of construction, maintenance of traffic, and traffic-control details
- Plan view sheets
- Design details
 - Overlay transitions at bridges, underpasses, B.O.P., and E.O.P.
 - Jointing details
- Standard drawings

Engineering Survey

The determination of whether or not a survey of existing conditions is needed during the design phase of a project will primarily depend upon the presence of vertical and/or horizontal constraints at the construction site and the condition of the roadway. When few constraints are present and mirroring existing contours is acceptable, a survey is not necessary. Plans need not include a proposed profile grade for these types of projects; the existing surface provides significant control information. Final profile will be determined during construction through the combination of minimum design thickness and design cross slope(s).

If, however, the existing roadway has significant surface distresses, ride-quality issues, drainage problems, or profile and cross-slope corrections, an engineering survey is recommended. This will allow the development of an optimized profile and an accurate estimate of the volume of concrete required to construct the overlay. Complex projects with multiple vertical and/or horizontal constraints should be surveyed during the design phase, and proposed finished elevations should be provided to the contractor to assure that conflicts between the overlay and existing conditions are avoided. A vertical control system should be established along the highway at 1,000-foot intervals to assist in the development of the plans and provide the construction forces with a basis for profile development.

Survey Methods

Regardless of technologies used such as GPS, total stations, differential leveling, or laser scanning technology the principals of survey and data collection apply. Horizontal and vertical control must be established throughout the project corridor so existing and proposed elevation models are relative to each other and can be verified at each phase. The control points should be numerous enough to facilitate the survey work as well as be available for the construction of the project. Normally, horizontal work is being performed with a total station and/or GPS, whereas vertical control is normally completed with total stations or component differential leveling. Total stations do have limitations for vertical control that needs to be understood by the surveyor. Therefore, component differential leveling (digital level preferred) is suggested to achieve the accuracy required. Physical cross sections of the roadway should be performed on 25 foot intervals or less for the whole project.

The decision of which technology to use is up to the surveyor/engineer and the available technology. Conventional survey is more labor intense when compared to LiDAR technologies of static and mobile laser scanning.

Laser Scanning

There has been a steady if not rapid progression of improvements in the surveying industry over the last decade. The efficiency and accuracy of collecting elevation data has been improved drastically over the tried and true rod and level method. The simplest method of control is to perform minor milling that is controlled with a traveling ski and cross-slope system. The advent of laser scanning has opened a new avenue for mapping of pavement surfaces before overlay construction to help eliminate excessive overruns. Laser scanning (Figure 56) can offer reduction in survey cost, savings in time, and less interference to the traveling public.

This increased efficiency makes it cost effective to perform in-depth surveys. Based on data obtained from a project constructed on US-18 in Iowa in 2012 (Cable 2012), it was found that performing a nine-line survey at 50-foot intervals provided the engineer with the data necessary to confidently adjust the profile of the concrete overlay and avoid a potential 20 percent quantity overrun in the cubic yards of concrete placed.

The latest development with laser scanning is basically several existing technologies combined into one unit or process. At the heart of the unit is the light detection and ranging (LIDAR) scanner, which measures the flight time of a beam of light to calculate the range to objects at predetermined angular increments, resulting in a very large-point data set referred to as a “Point Cloud.” The LIDAR or laser scanner conducts measurements to targets and a 360-degree camera is used to assist in identifying objects in the scan. The unit also includes a global positioning system

(GPS) to record its position on the earth surface at any time and the relative position of the objects being scanned. An inertial measurement unit (IMU) is used to account for movement (pitch, roll, and yaw) in the survey vehicle. A distance measuring instrument (DMI) is used to compute wheel rotation and measurements to aid the process. The system is capable of repeatable 0.04- to 0.12-inch accuracy in measurements. Appendix D provides further information about static or mobile scanning surveying.

Measurement and Payment Items for Concrete Overlays

It is strongly suggested that concrete overlays be measured and paid for by the square yard for placement and by the cubic yard for furnishing concrete material. This method has been used successfully for many years by DOTs that routinely design and construct concrete overlays. The purpose of providing a cubic-yard pay item for concrete overlays is to minimize the risk to both the owner and the contractor. The basis for using a cubic-yard pay item is the fact that the underlying surface is more irregular than a well-prepared subgrade or subbase would be.

Recognizing that DOTs are acting on behalf of the taxpayers and contractors are in the business of taking calculated risks, it does not seem inappropriate for DOTs to limit their risk to some degree. Assuming that the volume of concrete has been correctly estimated as recommended above, a cap on concrete overruns of 102 to 106 percent may be considered reasonable. The agency should make regular depth checks at the pavement edges, mid-lane, and centerline of the concrete overlay during construction to verify that the thickness of the concrete overlay is equal to or greater than the design thickness.

Establishing Plan Quantity for Overlay Concrete

There are two options to consider:

- For minimal preliminary work and cost
 - Do no preliminary survey other than measuring wheel rut depth and pavement cross slope at 500-foot intervals.
 - Develop design profiles of centerline and pavement edges.
 - Estimate the quantity of concrete required to meet the profiles and provide minimum thickness at centerline and edges of pavement.
 - Add a reasonable percentage to the concrete quantity to account for placement tolerance, construction losses, and surface/cross-section irregularities and establish the “new theoretical” plan quantity. Some states use 15 to 20 percent, depending on the thickness of the overlay and the amount of pavement cross-slope correction desired. The thinner the overlay and the higher the cross-slope correction, the higher the percentage; see Table 12.
- For optimization of concrete quantities
 - Conduct nine-shot cross sections at 50-foot intervals to map the existing surface.
 - Develop a design centerline profile and cross slope that optimizes pavement smoothness, maintains minimum overlay depth across the width of the pavement, and optimizes concrete quantities.
 - Limit the contractor to an additional percent of the quantity identified by the desired cross section and design profile. Some states use 2 to 6 percent, depending on the thickness of the overlay.

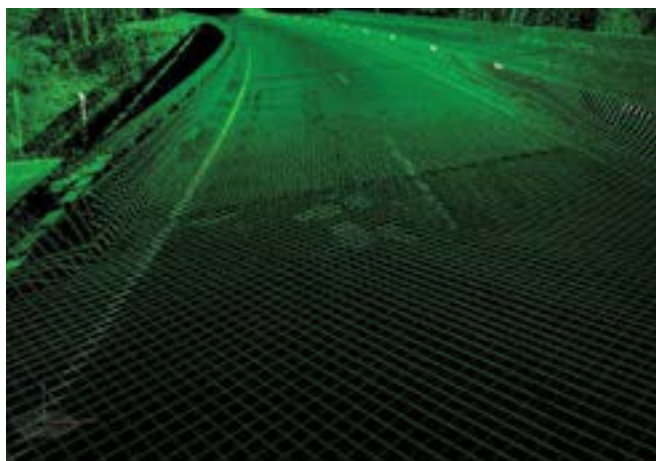

Figure 56. Digital terrain model acquired through laser scanning

Table 12. Typical Adjustment Factors for Estimating Overlay Cubic Yard Plan Quantities

Concrete Overlay Thickness	½ in. Placement Tolerance As a % of Design Thickness	Additional % Adjustment for Gross Surface Irregularities in the Existing Surface*	Total Adjustment Factor to Be Applied to Theoretical Volume
4 inches	12.5 %	5 %	17.5 %
6 inches	8.3 %	5 %	13.3 %
8 inches	6.3 %	5 %	11.3 %
10 inches	5.0 %	5 %	10.0 %
12 inches	4.2 %	5 %	9.2 %

* Gross surface irregularities are not affected by the overlay thickness; this is a constant that is entirely dependent on the existing surface condition and any other desired changes such as cross-slope correction and profile adjustment to obtain a smooth pavement. Table 12 reflects 5 percent as an example only. An appropriate percentage for gross irregularities should be developed from the measurements of wheel rut depth and pavement cross slope at 500-foot intervals.

Typical Costs of Concrete Overlays

Since the onset of the Concrete Overlay Field Application Program in 2009, construction cost has been a common question from state DOT personnel who are inexperienced with concrete overlays. To answer this question, bid tabulations from six state DOTs that are currently utilizing concrete overlays as an integral part of their pavement rehabilitation strategy were reviewed. Figure 57 shows the cost data collected from 33 projects with bid dates ranging from August 2008 through September 2009 (Fick 2010). These overlay costs include furnishing concrete, placing the overlay, and all costs associated with joints. Preoverlay repairs, surface preparation, and separation layer costs are not included, but note that the amount of required preoverlay repairs for a concrete overlay is significantly less than that for a typical HMA overlay.

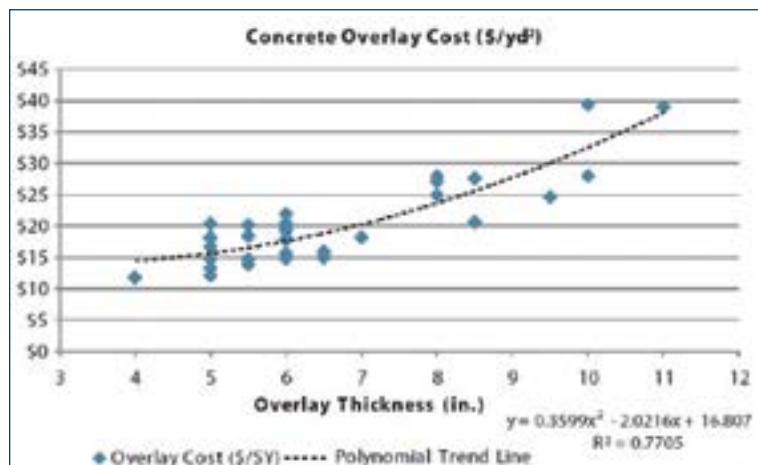

Figure 57. Concrete overlay cost by thickness (source: [Fick 2010])

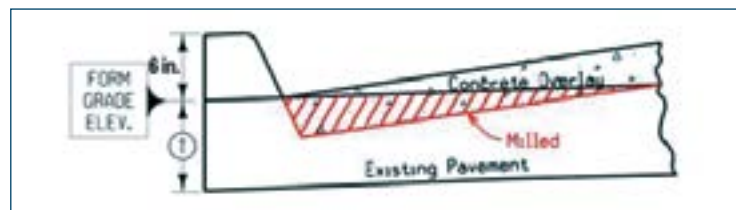

Figure 58. Milling detail when leaving the existing curb in place (source: Snyder & Associates, Inc.)

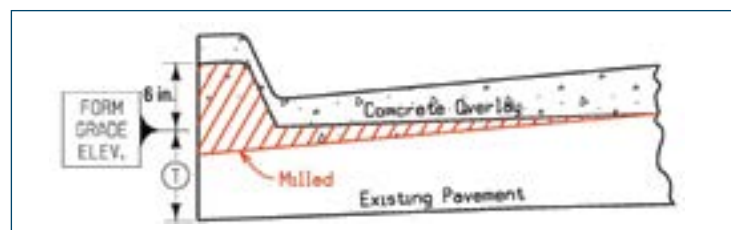

Figure 59. Milling detail when removing and replacing curb (source: Snyder & Associates, Inc.)

Miscellaneous Design Details

Following are design details related to curb and gutter (C/G), vertical grade changes, and other special design considerations.

Curb and Gutter Details

Potential constraints such as surface drainage should be considered in the design. Curb-and-gutter sections may pose challenges with respect to how to design a concrete overlay. Projects might include removal and replacement of the existing C/G, construction of an inlay with the final pavement elevation matching the existing C/G, or even an encasement of the existing C/G with a new system.

Curb-and-gutter sections require additional details since a decision needs to be made about jointing. (Figures 58 through 60 show three possible design options.) It is possible to include an integral C/G, but this should be balanced with the extent of this type of section and the equipment that might be available to construct it.

Leaving the Existing Curb in Place

To leave the existing curb in place, the milling operation stops at the base of the curb, allowing for the thickness of the concrete overlay; see Figure 58.

There is a cost savings associated with leaving the existing curb in place, since driveways, sidewalks, and utility fixtures do not require raising. The condition of the curb, however, should be evaluated and, if the concrete is showing signs of deterioration, it should be removed and replaced.

Also, when utility poles and other obstructions are in close proximity to the back of the existing curb, leaving the curb in place may prohibit the use of conventional slipform paving equipment.

Removing Curb and Gutter

When obstructions behind the curb prohibit the use of conventional slipform paving equipment, it may be advantageous to completely remove the curb and a portion of the gutter to allow placement of the concrete overlay a few inches higher than the existing curb; see Figure 59.

The full-depth section of C/G could be milled. When there are obstructions behind the curb, however, a full-depth saw cut and traditional excavation methods are preferable to minimize disturbance of materials on the edges of the roadway. In this case, a new C/G section can then be constructed after the overlay has been placed, using a curb paving machine.

Overlay Curb

It is possible to place a concrete overlay that encases the existing curb; see Figures 60 and 61.

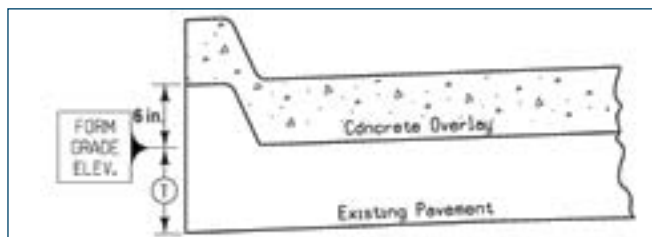

Figure 60. Detail of curb overlay (source: Snyder & Associates, Inc.)



Figure 61. Concrete curb overlay (source: Jim Amundsen, Grace Construction Products)

It should be noted, though, that this option raises the profile grade of the existing curb and may require adjustment of adjoining and adjacent roadway features.

Vertical Grade Changes

Depending on the vertical change in profile grade, there are numerous constraints that need to be considered in the overlay design process.

Overhead Clearance

Depending on the location of the project, various regulations for minimum overhead clearance may apply. The final pavement elevation and thickness may need to be limited or measures taken to raise overhead obstacles. Alternatively, it may be preferred to conduct full-depth reconstruction or build an alternative section (i.e., mill down and place a thinner but higher-strength concrete overlay) at such locations.

Barriers and Rails

Safety barriers, guardrails, and cable barriers may need to be raised/reconstructed depending on the change in profile grade and the horizontal distance between the edge of pavement and the safety feature.

Safety Edge

When the roadway is raised, it is necessary to determine whether or not the new safety slopes can fit to the existing ditches and remain within the appropriate safety design criteria. In some cases, it may be necessary to regrade the ditches to meet safety slope criteria. The safety edge is a beveled pavement edge to help lessen the severity of roadway departures; see Figure 62. When a driver drifts off the paved surface, the safety edge provides greater ease in reentering the roadway and reduces the risk of oversteering and loss of control of the vehicle.

Most likely, the projects that will need a safety edge will be two-lane, rural highways without paved shoulders. Most of these projects would be resurfacing projects. The angle of the bevel is important for the safety edge to function properly. Measured from level, the bevel is 30° with an equivalent run-to-rise ratio of 10.5 to 6.

Note the 30° angle does not account for surface slope. Existing surface slopes range from 2 to 8 percent, which add an additional 1.1 to 4.6 degrees to the bevel angle when measured from level. The resultant angle is within the

30- to 35-degree recommendation from the FHWA. All safety edge requirements should follow state agency requirements.

See Chapter 6 for temporary centerline fillets.

Cross Road Drainage Structures

When safety slopes are regraded to meet appropriate design criteria, it may be necessary to extend drainage structures to match the new foreslopes.

Cross Slope and Superelevation

Changes to cross slope and superelevation can lead to thicker concrete overlay sections. For cost effectiveness, designers should consider matching existing cross slopes whenever possible. When crown and/or superelevation corrections are required, adequate information on the depth of material to meet the final grade is also required. The type of fill materials to use (concrete, asphalt, flowable fill, cement-treated base, etc.) should be selected based on the depth of fill, installation and construction issues, initial costs, and future removal costs. Some projects combine over-

lays with full-depth reconstruction to address extreme corrections in superelevation.

Typically, the desired results are not achieved when an asphalt separation layer is utilized for correcting cross slope and profile (smoothness) deficiencies. This is because variable asphalt thickness, when compacted, creates variable roll down; the result is a nonuniform surface that still must be corrected with additional concrete thickness. The most effective and economical way to make corrections is to make cross slope and smoothness adjustments in the concrete overlay; see Figure 63. There are some considerations to make, however, when correcting cross slope and profile features through a variable thickness concrete overlay:

- The depth of saw cut for contraction joints must be adjusted through the thicker areas of concrete placement.
- Dowels should be placed (baskets or mechanical inserters) so that a minimum cover of 2 inches is maintained around the dowel bar (see Snyder 2011 for additional information).

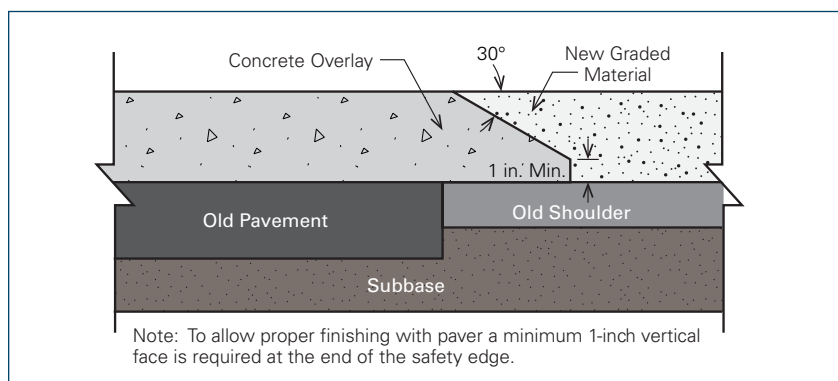

Figure 62. Typical safety edge for concrete overlay without paved shoulder

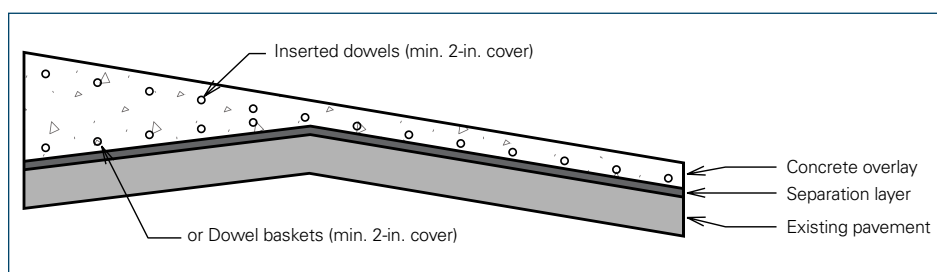

Figure 63. Dowel options in superelevation areas

In-place Pavement Structures

Existing manholes, inlets, and utility structures must be raised to match the new pavement elevation. Figure 64 shows typical details for raising a manhole.

Plate Dowel Details

Unbonded concrete overlays can be constructed with different construction practices, installation procedures, and joint types, requiring different installation procedures and plate geometries; see Figure 65.

See Table 13 for plate dowel size and spacing for construction joints and Table 14 for dowel size and spacing for contraction joints.

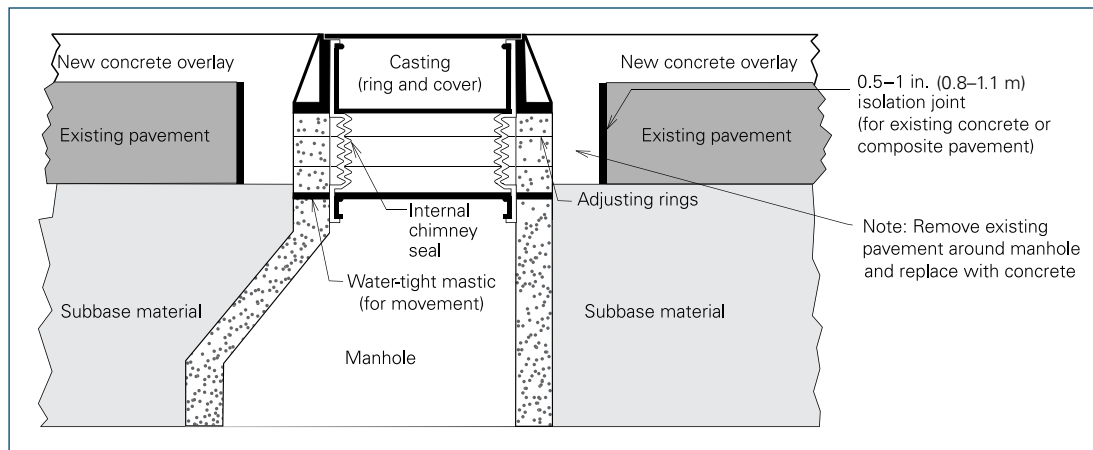

Figure 64. Concrete overlay with standard manhole



Figure 65. Diamond-shaped plate dowels in fixed-formed construction joints (right side) and football-shaped dowels by slipforms

Table 13. Size and Spacing of Plate Dowels for Construction Joints

Pavement Depth	Plate Dowel Thickness and Width at Joint	Plate Spacing for Heavy Traffic, Wide Joint Openings, or Both	Plate Dowel Spacing for Light Traffic or Narrow Joint Opening
125 to 174 mm	6 mm x 160 mm	450 mm	600 mm
175 to 224 mm	10 mm x 160 mm	450 mm	600 mm
225 mm+	20 mm x 160 mm	450 mm	600 mm

Table 14. Size and Spacing of Plate Dowels for Contraction Joints

Pavement Depth	Plate Dowel Thickness and Width at Center Line of Plate	Plate Spacing for Heavy Traffic, Wide Joint Openings, or Both	Plate Dowel Spacing for Light Traffic or Narrow Joint Opening
125 to 174 mm	10 mm x 50 mm	450 mm	600 mm
175 to 224 mm	13 mm x 65 mm	450 mm	600 mm
225 mm+	20 mm x 65 mm	450 mm	600 mm

Corrosion Resistance

Where corrosion resistance for plate dowels is required, they are generally either galvanized or electroplated with zinc, but other methods such as epoxy coating may also be appropriate.

Plate Dowel Installation for Construction Joints Formed with a Bulkhead (Form)

Alignment or installation devices should be incorporated into the bulkhead (forms) to ensure that dowels are centered in the joint, horizontal with the pavement’s surface, and perpendicular to the joint; see Figures 66 and 67.

Dowel installation devices that remain in the pavement and transfer load to the concrete by bearing should be made of thin, rigid material to help minimize the vertical deflection. Dowel installation devices that are loose fitting or made of soft material can result in significant initial vertical deflection that may cause early joint deterioration (Walker and Holland 2007).

Plate Dowel Installation in Slipform or Full-depth Saw Cut (Butt-type) Construction Joints

In slipform or full-depth saw cut construction joints (as would be encountered in a remove-and-replacement area of topping), designers

should recognize that when new concrete topping, with an inherent tendency to shrink, is tied to previously placed concrete topping that has already gone through the shrinkage process, stresses will develop that can cause cracking; see Figures 68 and 69.

Load transfer between previously placed sections and newly placed concrete can be obtained through the use of football-shaped plate dowels. In this application, slots can be cut into the existing slab to receive the plate dowels. An epoxy or similar material should be used to rigidly grout the plate into the slot to ensure a tight fit.

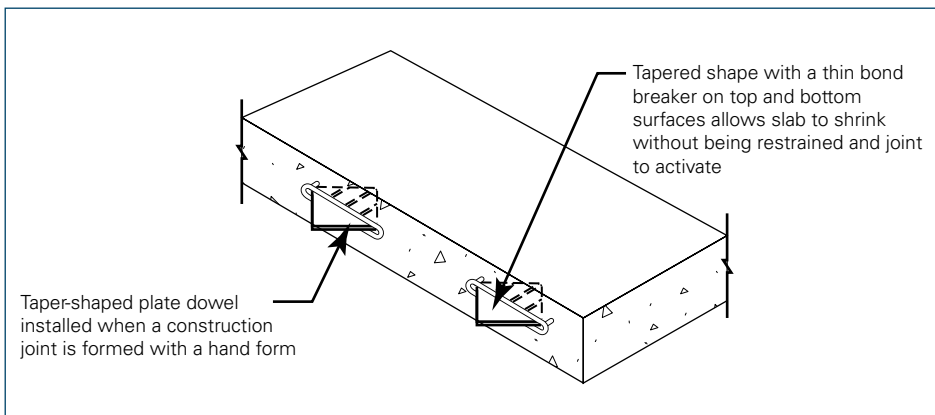

Figure 66. Detail of construction joint plate dowel for fixed-form paving



Figure 67. Taper-shaped construction joint plate dowel using fixed forms (source: Nigel Parks, PNA Construction Technology)

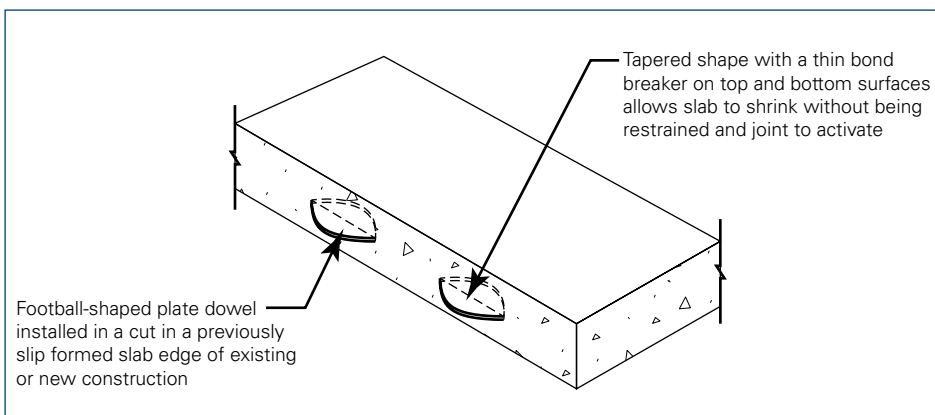

Figure 68. Detail of construction joint plate dowel for slipform paving



Figure 69. Slots being cut to accept the football-shaped plate dowels (source: Nigel Parks, PNA Construction Technology)

Dowel Installation for Contraction Joints

Dowel baskets or mechanical dowel bar insertion equipment should be used to maintain alignment of tapered plate dowels in saw-cut

contraction joints. In this application, the tapered plate dowels allow for horizontal misalignment of the dowels without locking joints, inducing restraint or cracking in the overlaid concrete topping; see Figures 70 and 71.

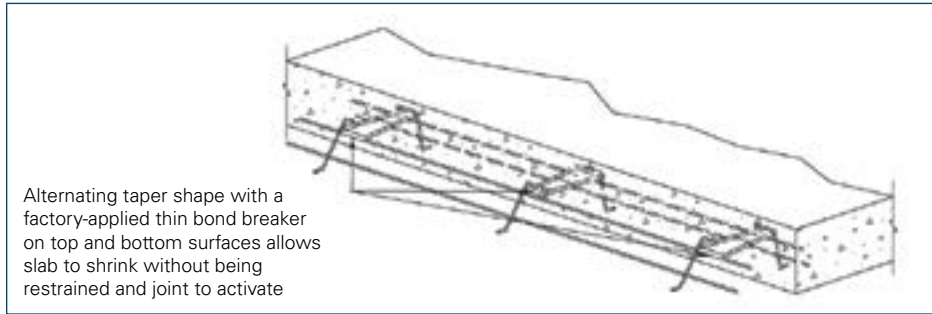

Figure 70. Detail of plate dowel for contraction joint

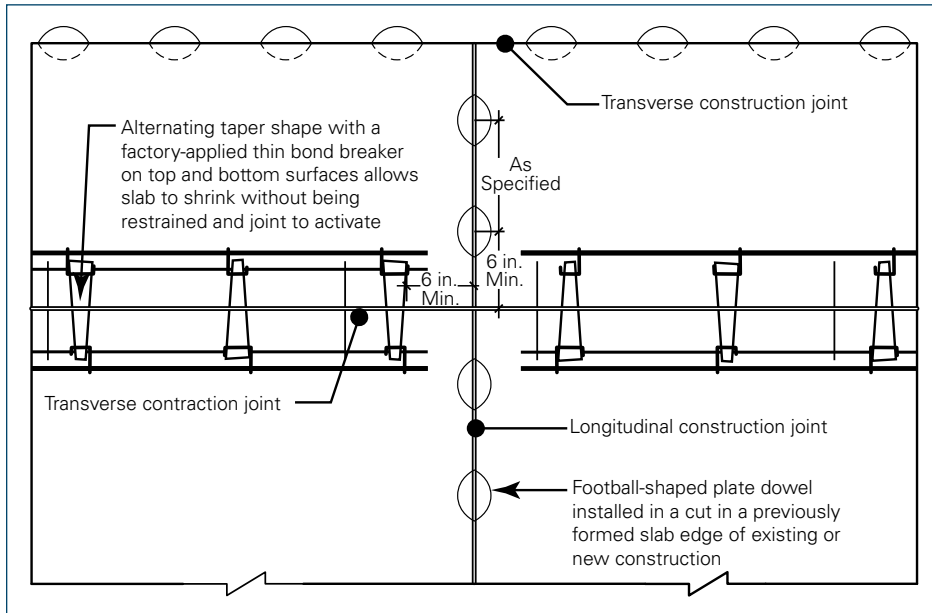

Figure 71. Plan view of roadway with plate dowels

Transitions

A concrete overlay design often requires transition details that link the concrete overlay with the pavement structure adjacent to the project length. Since these locations are often subject to additional stress, , including thicker

concrete sections, conventional reinforcement or wire mesh, and structural macro fibers. Transitions must be designed and constructed to connect the new overlay pavement with (1) existing pavement, (2) existing structures, and (3) driveways.

Figures 72 through 79 provide details for various transitions used for overlay construction. In general, transition length should be based upon the design speed—40:1 for roadways posted at 45 mph (miles per hour) or greater and 25:1 for speeds less than 45 mph.

Mill and Fill Transitions for Bonded Concrete Overlays

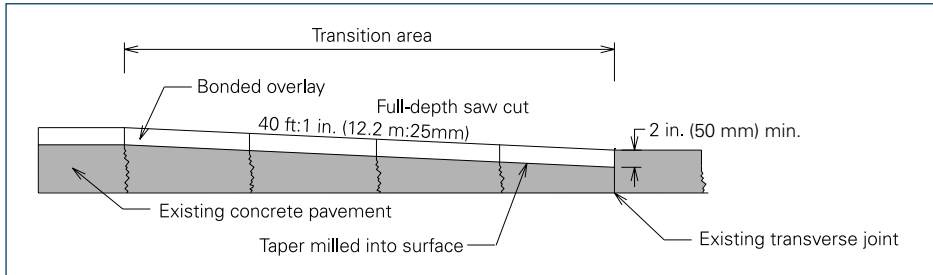

Figure 72. Mill and fill transition for concrete overlay of concrete pavement (adapted from ACPA 1998)

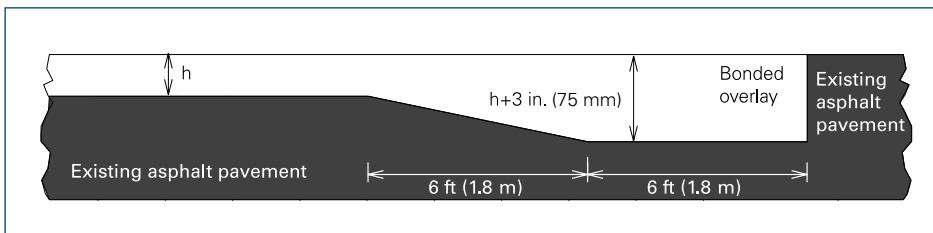

Figure 73. Mill and fill transition for concrete overlay of asphalt or composite pavement (adapted from ACPA 1998)

Transition Details for Bonded Concrete Overlays

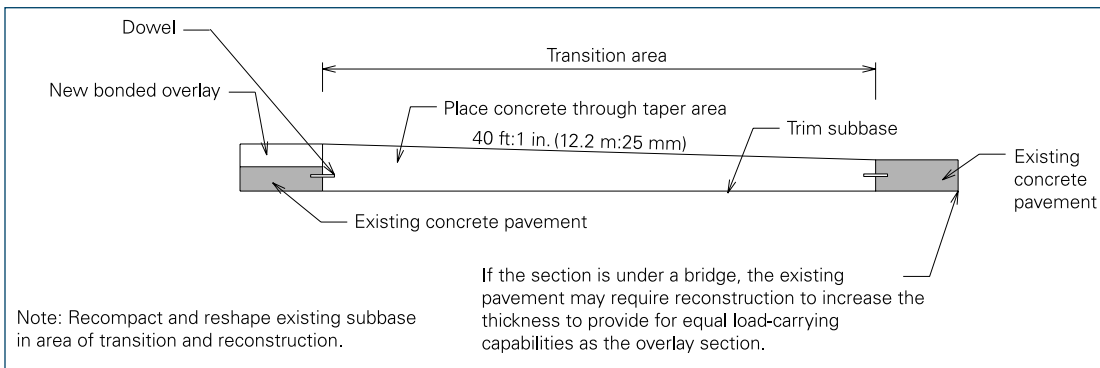

Figure 74. New transition tapers used to meet bridge approach slabs or maintain clearance under bridges with bonded overlay of concrete pavement (adapted from ACPA 1990b)

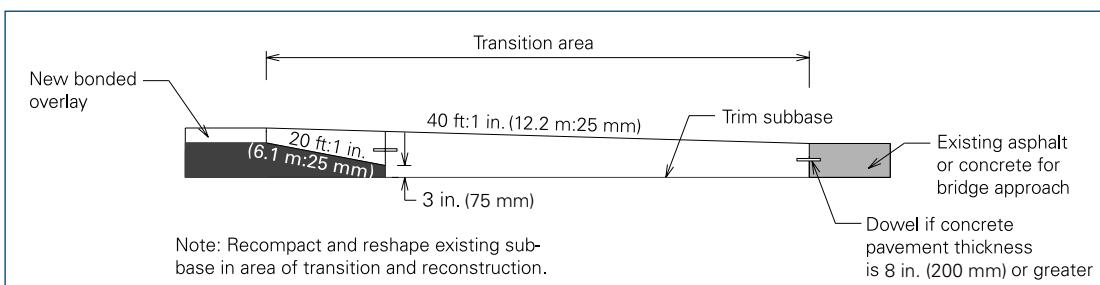

Figure 75. New transition tapers used to meet bridge approach slabs or maintain clearance under bridges with bonded overlay of asphalt pavement (adapted from ACPA 1991)

Transition Details for Unbonded Concrete Overlays

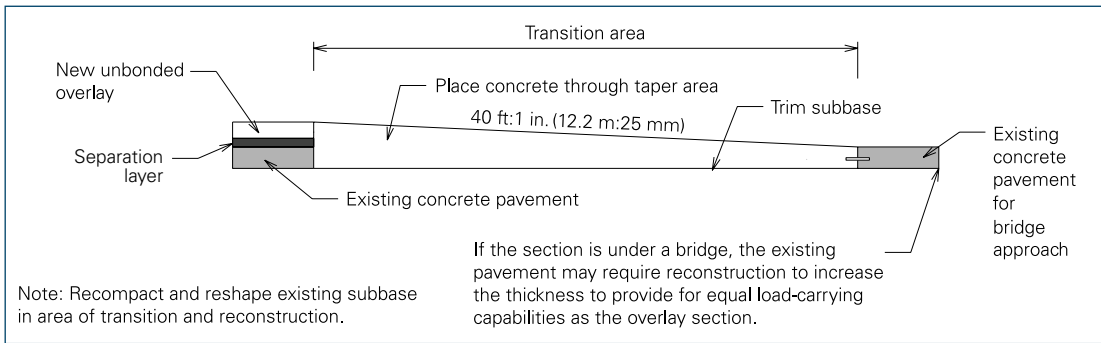

Figure 76. New transition tapers used to meet bridge approach slabs or maintain clearance under bridges with unbonded overlay of concrete pavement (adapted from ACPA 1990b)

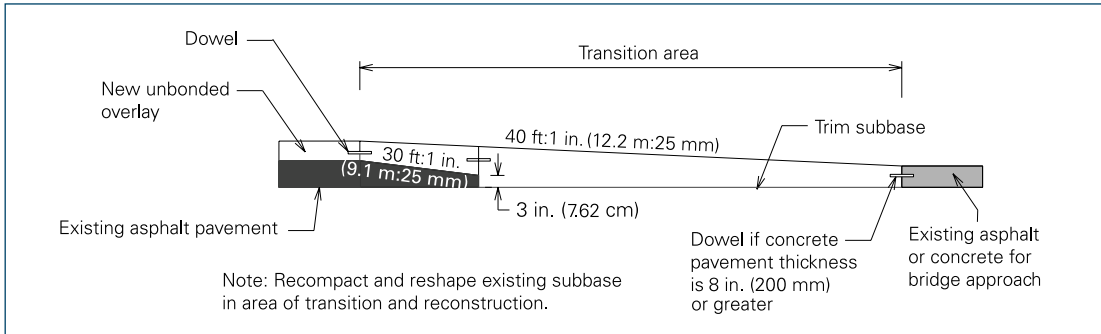

Figure 77. New transition tapers used to meet bridge approach slabs or maintain clearance under bridges with unbonded overlay of asphalt pavement (adapted from ACPA 1991)

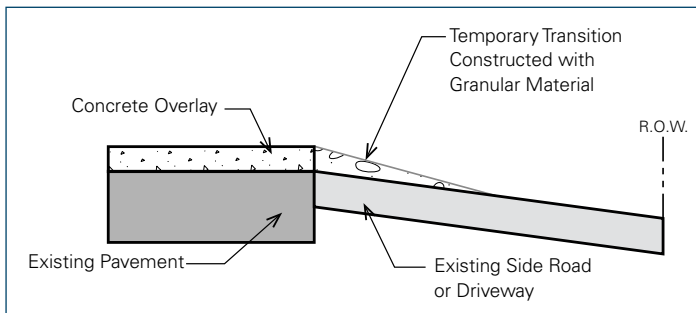

Figure 78. Temporary granular transition to existing side road/driveway

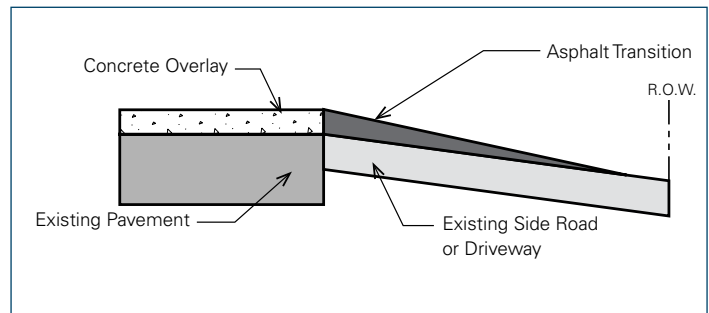

Figure 79. Asphalt wedge transition to existing side road/driveway

Widening and Lane Addition

Adding new lanes or shoulders can also present issues unique to concrete pavement design, especially if there is a change in the underlying support of the overlay or if the overlay is to join a full-depth concrete pavement. Joint load transfer systems are frequently used in these cases. Tiebars are used to help ensure aggregate interlock. Additional measures should be taken in the design to minimize differential settlement or water infiltration at these locations. For the same reasons, intersections and blockouts for utilities need to be understood, and joint patterns need to be developed that will minimize uncontrolled cracking.

Concrete overlay projects provide a good opportunity for the widening of an old pavement with narrow traffic lanes, the addition of new travel lanes, or the extension of ramps. Adequately designed and constructed widening can improve both faulting and cracking performance of the pavement.

Widened slabs should be used with care with concrete overlays on stiff foundations (such as on concrete pavements) because of the increased risk of longitudinal cracking.

Three- to six-foot (0.9- to 1.8-m) widening units are illustrated in Figures 80 through 84. The intent of the tiebars shown in Figures 80 to 82 is to tie the widening unit to the existing pavement. In Figure 82, note that care must be exercised not to loosen stapled tiebars with truck tires; when horizontal lane restrictions exist that require driving over the stapled bars, a better option may be to use a tiebar inserter.

Following are some rules of thumb for widening units:

- Where possible, keep joints out of wheel paths, especially for bonded overlays on asphalt or composite pavements.
- For concrete overlays 5 in. (125 mm) or thicker at open-ditch (shoulder) sections, tie longitudinal joints with no. 4 tiebars to prevent pavement separation.
- The width of widening rather than depth has more of a positive effect in reducing stresses in the overlay section.

Not every detail shown will fit a specific project. Apply the principles illustrated in the details to address specific project issues.

Lane addition design details are illustrated in Figure 85, on the following page. To prevent cracking related to differential expansion and contraction between a concrete overlay and a full-depth adjacent concrete lane addition, use a butt joint with no tiebars.

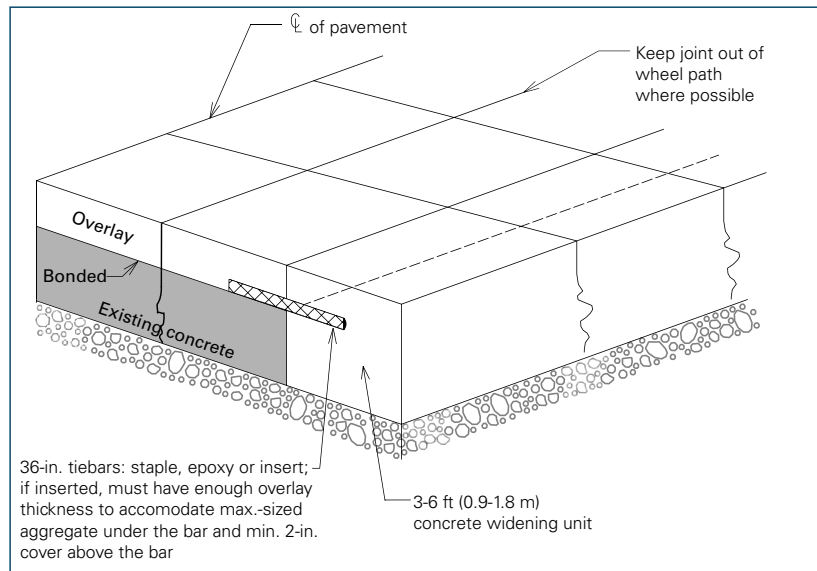

Figure 80. Bonded overlay of concrete pavement with widening unit

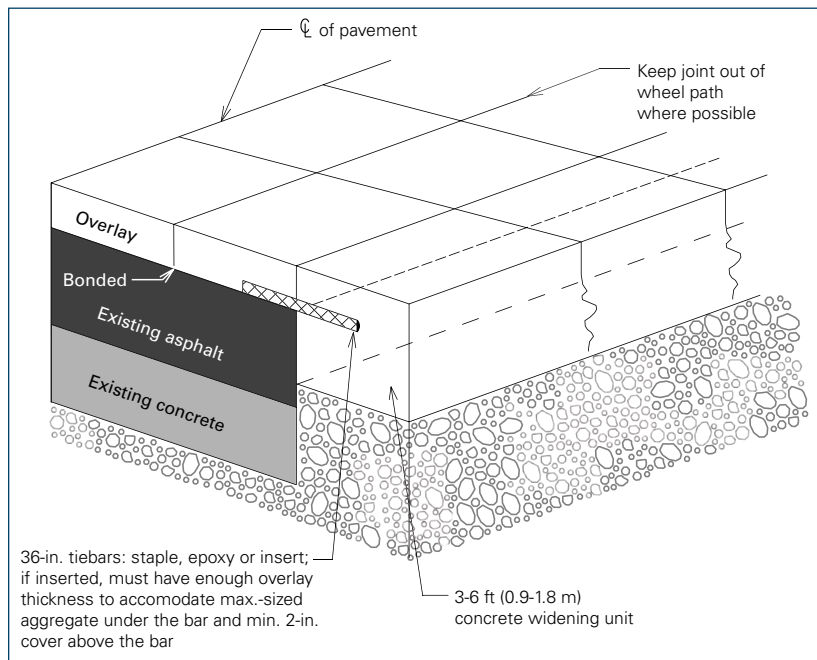

Figure 81. Bonded overlay of asphalt or composite pavement with widening unit



Figure 82. View of tiebars for concrete overlay widening unit

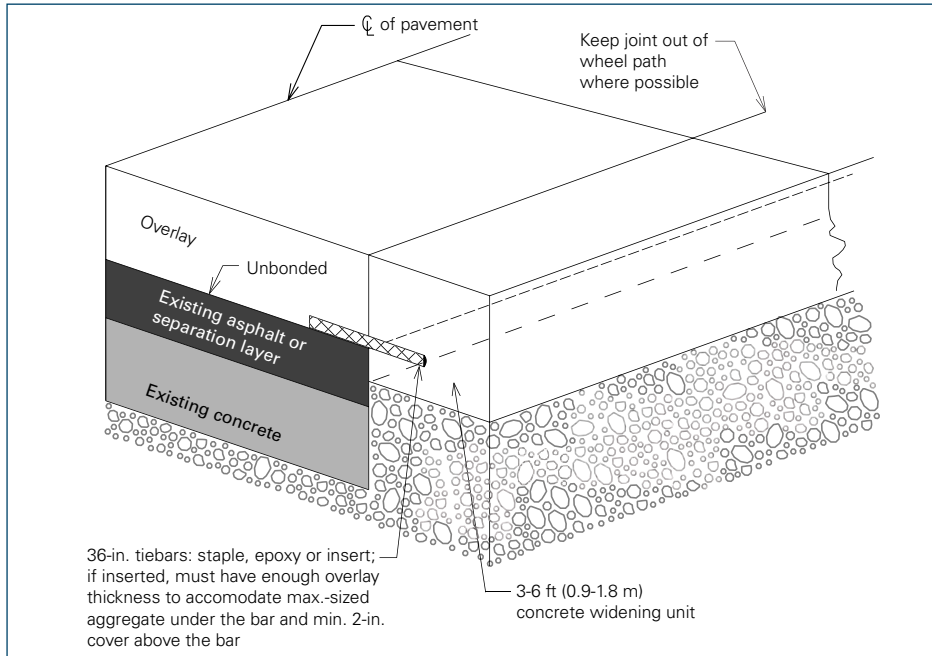

Figure 83. Unbonded overlay of concrete, asphalt, or composite pavement with widening unit

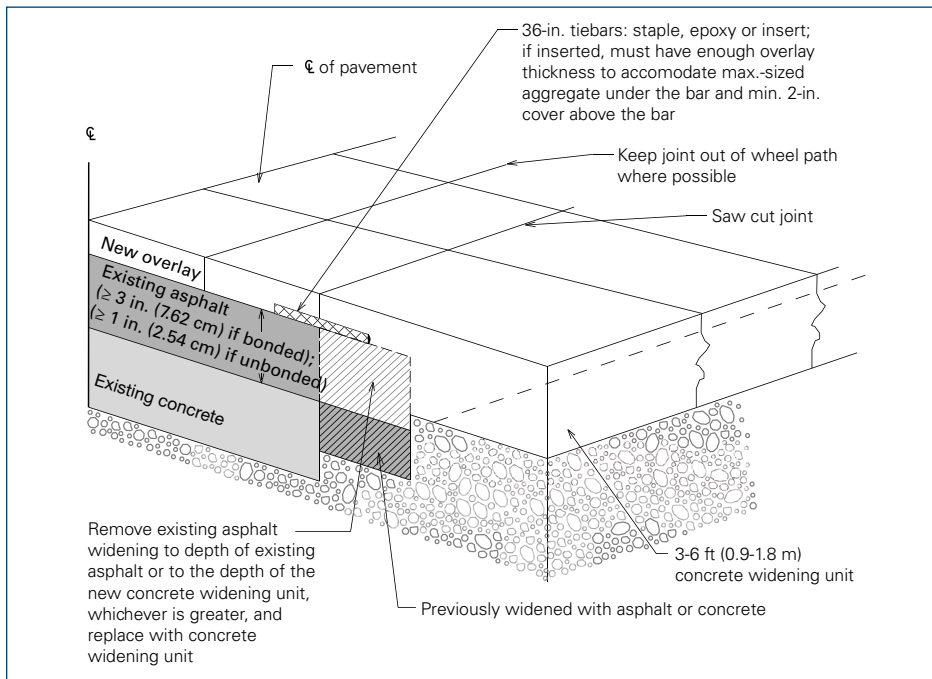

Figure 84. Bonded or unbonded overlay of asphalt or composite pavement (previously widened with asphalt or concrete, and to be widened again with new concrete overlay)

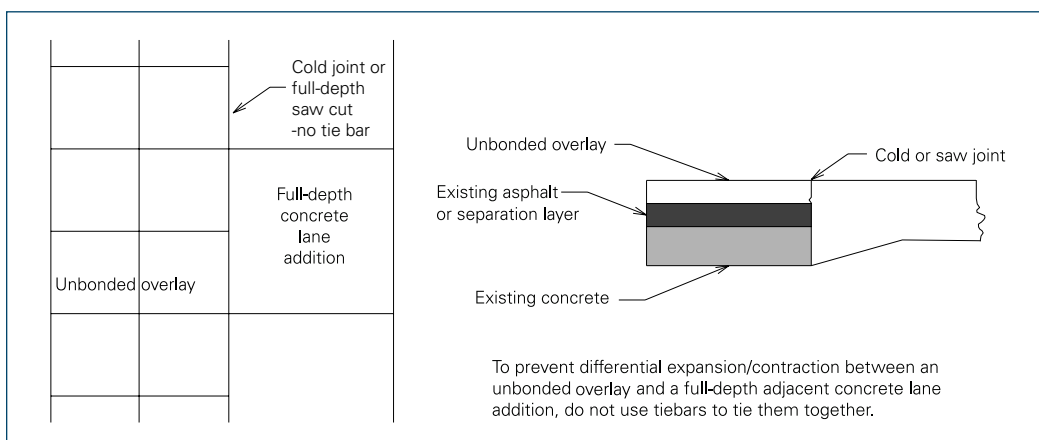

Figure 85. Unbonded overlay of concrete, asphalt, or composite pavement with full concrete lane addition

Typical Drainage Outlets for Interlayers

Figures 86 through 90 illustrate various drainage outlets for separation layers.

Rural Conditions

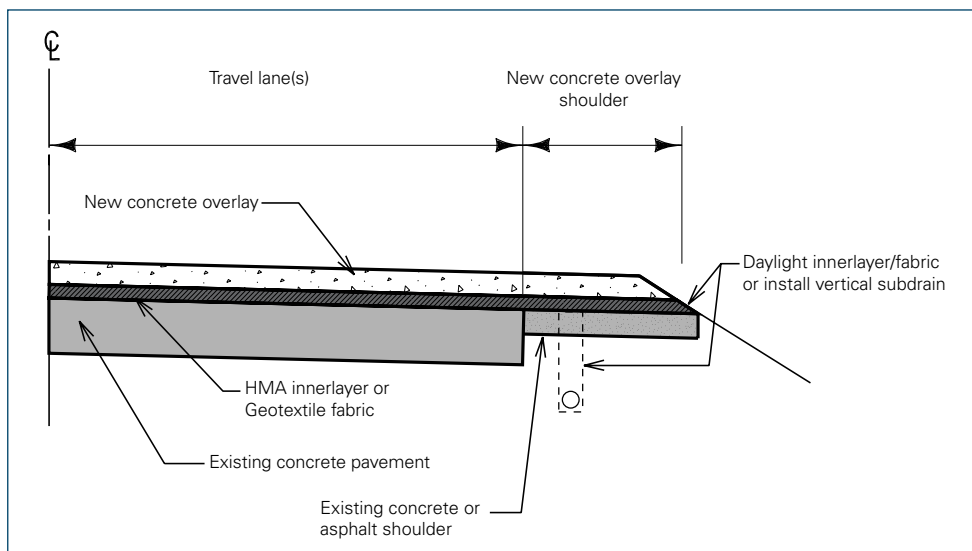

Figure 86. Interlayer outlet for concrete overlay shoulder

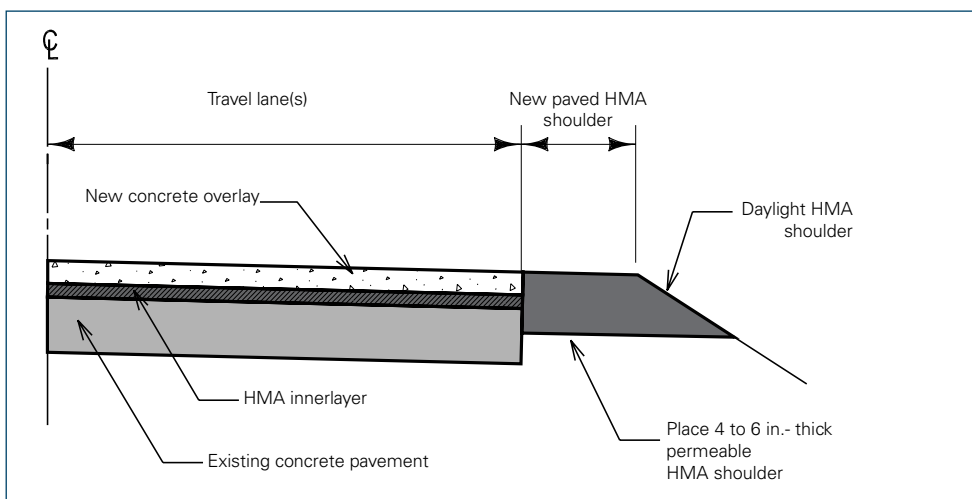

Figure 87. HMA interlayer outlet for asphalt shoulder

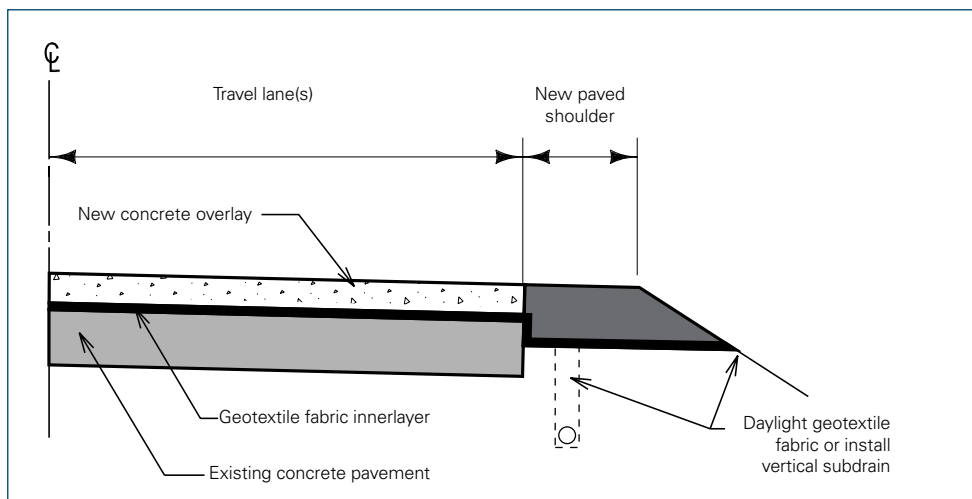

Figure 88. Geotextile interlayer outlet with new paved shoulder (concrete or asphalt)

Urban Conditions

Curbs Removed and Replaced

Water pressure in a geotextile fabric separation layer can be reduced by draining the fabric into storm sewer inlets. If the existing curb is removed and replaced with the overlay, the geotextile layer can be daylighted out to an existing or new subdrainage system; see Figure 89.

Curb Remaining

If the curb is not removed for construction of an unbonded overlay, the geotextile layer that separates the underlying concrete pavement from the overlay can be drained into an intake. The fabric will need to be tied into the wall of the intakes; see Figure 90.

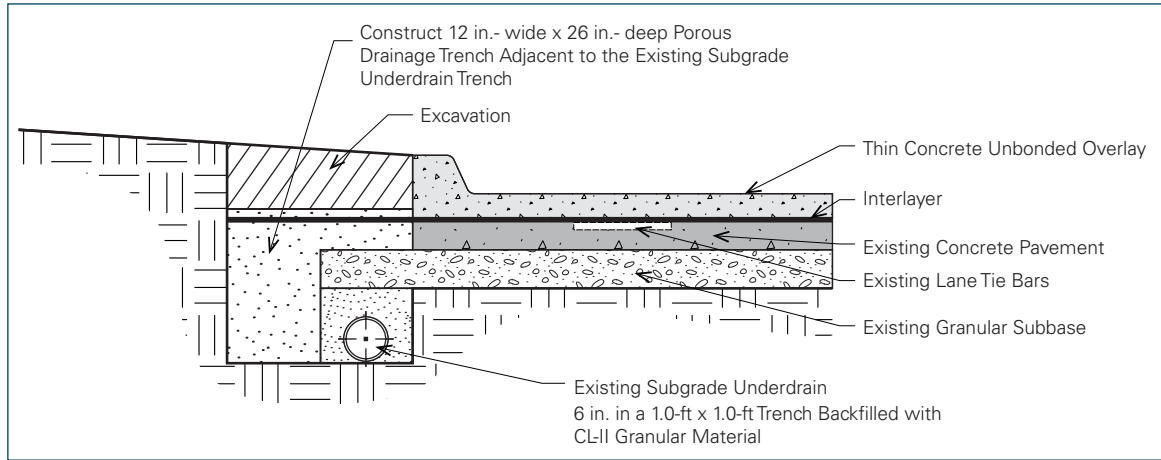

Figure 89. Drainage of separation layer (interlayer) into an existing underdrain system when existing curb is removed and replaced (source: Dan DeGraaf, Michigan Concrete Association)

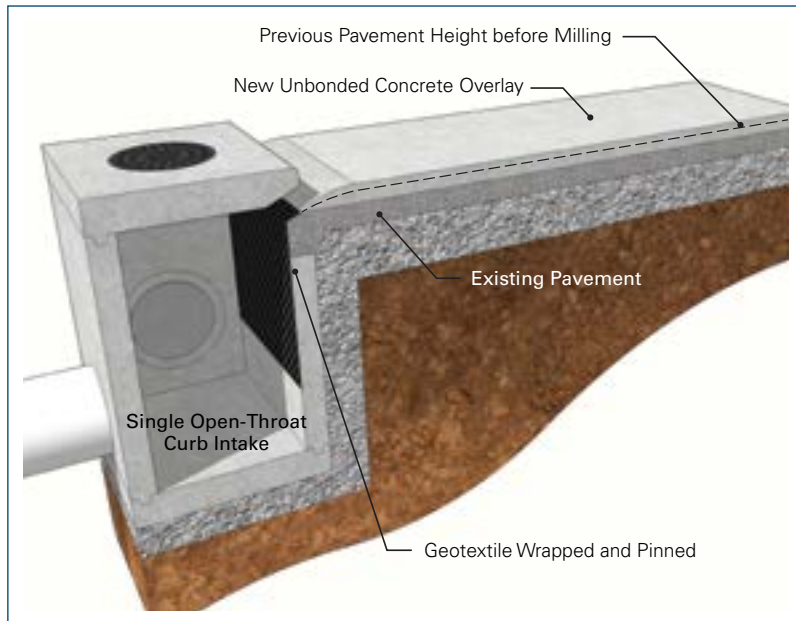

Figure 90. Drainage of separation layer fabric into intake when curb is not removed (source: Snyder & Associates, Inc.)

Chapter 5.

CONCRETE OVERLAY MATERIALS AND MIXTURES

A majority of concrete overlay mixtures are designed and constructed using standard materials. These materials include cement, supplementary cementitious materials (SCMs), aggregates, water, and admixtures.

Concrete mixtures can be either conventional or, in special circumstances, accelerated; both types of concrete mixtures can be fiber reinforced. Other materials associated with concrete overlays include dowel bars, tiebars, curing compound, joint sealant, and separator layers.

This guide classifies concrete mixtures as either conventional or accelerated. The primary difference is that accelerated mixtures are designed for a faster rate of strength gain, allowing earlier opening of the concrete overlay to construction and/or public traffic (see page 105 for comprehensive guidance on accelerated construction techniques). Producing a durable concrete mixture should be the primary objective regardless of whether the mix is conventional or accelerated. This guide provides general recommendations for developing durable concrete mixtures to be used in concrete overlays. The design and production of concrete mixtures for concrete overlays should adhere to best practices for local requirements (i.e., aggregate durability, air entrainment, etc.).

Primary Concrete Materials

The primary materials in concrete are cementitious materials, water, aggregate, and admixtures.

Cementitious Materials

Type I and Type II cements are commonly used in concrete mixtures for concrete overlays. When high early strength is desired, higher amounts of Type I can be used. Since conventional Types I and II cements are normally adequate, the use of Type III cements with overlays is not recommended because of increased thermal shrinkage and potential for thermal shock. As with conventional paving, SCMs normally improve durability and can enhance the ease of construction.

Replacement of some cement with SCMs in well-cured concrete has multiple benefits ranging from improved workability to reduced permeability of the hardened con-

crete. Typical replacement rates with SCMs are 15 to 35 percent, depending on the chemistry of the system. Commonly used SCMs include Class C fly ash, Class F fly ash, and ground granulated blast furnace slag (GGBFS).

Setting times for concrete may be retarded when SCMs are used, especially in cool weather conditions, which can cause difficulty in sawing joints before random cracking occurs. Therefore, heating of the concrete and/or the use of accelerating admixtures is recommended during periods of extended cool weather. Ensure that the strength gain of the mixture is compatible with the sawing plan (HIPERPAV can assist in assessing the risk of random cracking). More information is available in the *Integrated Materials and Construction Practices for Concrete Pavement* (Taylor 2006).

Since SCMs can retard set time in cold weather, some agencies restrict their use in colder seasons of the year. Supplementary cementitious materials can, however, aid construction during hot weather by extending the placement time. They typically improve the workability of the mix and also increase concrete durability; they also can increase the long-term strength of the concrete, although the short-term strength may be lower. In addition, fly ash and GGBFS are effective in reducing ASR (ASR mitigation should be confirmed by ASTM 1567).

Aggregates

Aggregates used in concrete mixtures range from crushed stones to river gravels and glacial deposits. To help ensure the longevity of the pavement, the aggregate should not only possess adequate strength but also be stable physically and chemically within the concrete mixture. Agencies generally require that aggregates conform to ASTM C 33 for physical properties; a well graded mixture should be specified. Extensive laboratory testing or demonstrated field performance is often required to ensure the selection of a durable aggregate.

The use of well graded aggregates helps to improve permeability in several ways; see Table 15. First, mixtures made with well graded systems tend to be more workable, which in turn means that less water is required to achieve the same workability, allowing use of a lower w/cm ratio. Second,

well graded systems allow use of higher aggregate and lower paste contents. Because paste is more permeable than aggregate, reducing paste content while maintaining workability will lead to reduced permeability (Yurdakul 2010). Third, better workability will lead to better consolidation of the mixture, also improving (reducing) permeability (Tayabji et al. 2007) and reducing the risk of overvibration and the attendant problems. Finally, the improved workability of well graded concrete mixtures allows for more efficient placement, especially in handwork, which means that the pavement is able to be finished earlier while the mix is still fresh.

The maximum coarse aggregate size used in concrete mixtures for overlays is a function of the overlay thickness. Some thinner concrete overlays may require a reduction in size of the standard aggregate used in concrete paving. It is recommended that the largest practical maximum coarse aggregate size be used in order to minimize paste requirements, reduce shrinkage, minimize costs, and improve mechanical interlock properties at joints and cracks.

Although maximum coarse aggregate sizes of 0.75–1 in. (19–25 mm) have been common in the last two decades, smaller maximum coarse aggregate sizes may be required for

Table 15. The Effect of Aggregate Gradation on Mixture Properties

Well Graded Aggregates
Concrete mixtures produced with well graded, dense aggregate matrix tend to
<ul style="list-style-type: none"> • Reduce the water demand • Reduce the cementitious material demand • Reduce the shrinkage potential • Improve workability • Require minimal finishing • Consolidate without segregation • Enhance strength and long-term performance
Gap-graded Aggregates
Concrete mixtures produced with a gap-graded aggregate combination may
<ul style="list-style-type: none"> • Segregate easily • Contain higher amounts of fines • Require more water • Require more cementitious material to meet strength requirements • Increase susceptibility to shrinkage • Limit long-term performance

concrete resurfacing. For nonreinforced pavement structures, a maximum aggregate size of one-third of the slab thickness is recommended.

When selecting aggregate for a bonded concrete overlay on an existing concrete pavement, the CTE becomes a particularly important parameter. Because aggregate composes a majority of the concrete's mass, its CTE is a good indicator of concrete movement due to thermal expansion and contraction. Using an aggregate in the overlay mixture with a CTE similar to that of the existing pavement helps ensure that the two layers move together, thus minimizing stress at the bond line due to differential movement and helping to maintain the bond between the layers. The CTE can be determined using AASHTO provisional test TP-60 (Coefficient of Thermal Expansion of Hydraulic Cement Concrete).

If not similar to the CTE of the underlying concrete pavement, the CTE of the overlay should be less than that of the underlying pavement. The overlay surface is exposed to greater temperature swings than the underlying pavement. Therefore, the lower the overlay's CTE, the less the differential movement between the overlay and underlying pavement.

Admixtures

Various admixtures and additives are commonly introduced into concrete mixtures. These include the following:

- Air entrainment protects the hardened concrete from freeze-thaw damage and deicer scaling. Air entrainment, however, also helps increase the workability of fresh concrete, significantly reducing segregation and bleeding. The typical entrained air content of concrete for overlays is in the range of 5 to 7 percent.
- Water reducers are added to concrete mixtures in order to reduce the amount of water required to produce concrete of a given consistency. This allows for a lowering of the w/cm (water-cementitious) ratio while maintaining a desired slump and thus has the beneficial effect of increasing strength and reducing permeability.

Conventional Concrete Mixtures

Conventional concrete paving mixtures are typically used in the construction of concrete overlays. As with conventional concrete pavements, an effective mixture design is essential to the performance of a concrete overlay. Each

of the components used in a concrete mixture should be carefully selected so that the resulting mixture is dense, relatively impermeable, and resistant to both environmental effects and deleterious chemical reactions over the length of its service life.

There are numerous references for developing durable concrete mixtures; the following section is adapted from the *Guide for Optimum Joint Performance of Concrete Pavements* (Taylor et al. 2012), which provides recommendations for designing and constructing durable concrete pavements.

The permeability of a concrete mixture determines how easily moisture can infiltrate the paste structure of the concrete. A lower permeability is desirable to slow the rate at which concrete will become saturated. Recent work led by the South Dakota DOT includes recommendations to achieve durable, dense, and impermeable concretes that withstand the deleterious effects of deicing chemicals (Sutter et al. 2008) and prevent or reduce joint deterioration caused by water saturation at the joints. Recommendations include designing mixtures with low w/cm ratio, adequate air void systems, appropriate use of SCMs, and well graded aggregates.

Target permeability at 56 days should be less than 1,500 coulombs when tested in accordance with the rapid chloride permeability test (ASTM C 1202) or 25 kΩ-cm when tested using surface resistivity measured in accordance with AASHTO TP 95.

Low w/cm Ratio

The permeability of a concrete mixture is primarily governed by the amount of water in the concrete at the time of mixing. Permeability will decrease as less water is used. The w/cm ratio should not exceed 0.45; ideally, the w/cm ratio should be between 0.38 and 0.42 (especially for wet freeze-thaw environments).

There are a number of ways to achieve uniformly lower w/cm ratios while retaining satisfactory workability, including combinations of the following:

- Using SCMs in appropriate dosages
- Using water-reducing admixtures
- Using aggregate systems with combined gradation, which promotes reduced paste volume and improved workability
- Controlling concrete temperature
- Not adding water to a ready-mix truck at the point of delivery, which exceeds the design w/cm

Adequate Air Void System

Freeze-thaw durability is primarily affected by the environment (wet freezing conditions) and the air void system of the concrete. An air void system consisting of many small, closely spaced voids is a common means of providing protection against freeze-thaw damage. An adequate air void system in the as-placed concrete is vital. Air void systems can be affected by varying the composition of concrete constituents, placing techniques, and finishing activities. For concrete that is exposed to deicing chemicals or high water saturation (which is considered "severe exposure"), a spacing factor equal to or below 0.008 in. (0.2 mm) is recommended, along with a specific surface area of air voids equal to or greater than 600 in.²/in. (24 mm²/mm). PCA Bulletin EB001.15 recommends a minimum of 5 percent to 8 percent air content in the in-place concrete to prevent damage (Kosmatka and Wilson 2011). In addition, Sutter and Ley have reported that these values are still appropriate based on recent laboratory work (Ley et al. 2012).

Test procedures to determine air content in fresh concrete include the pressure method (ASTM C 231/AASHTO T 152), the volumetric method (ASTM C 173/AASHTO T 196), and the gravimetric method (ASTM C 138/AASHTO T 121). The air content should be checked in samples taken in front of the paver, and periodically from behind the paver, to quantify how much air content is lost during placing. By periodically comparing air content difference between samples taken from the same hauling unit both before and after the paver, the stability or quality of the air system can be estimated. When the difference between the two test results is less than 2 percent, the hardened air-determined spacing factor is usually acceptable. If the difference is greater than 2 percent, then admixture dosage of the mixture should be adjusted and/or the placement processes modified to ensure adequate protection of the in-place system. Concrete performance can be assessed in the laboratory (during design stage) using ASTM C 666/AASHTO T 161.

Accelerated Mixtures

Although the use of accelerated mixtures and expedited paving practices has become more common in concrete overlay projects, there has been some concern regarding potential detrimental effects of faster-setting concrete mixtures and reduced construction times on the long-term durability of concrete due to excessive shrinkage, heat generation, and poor microstructure.

FAQ—How do I determine the appropriate opening strength?

Opening strength should be determined based on the anticipated early loading traffic, concrete overlay thickness, and ability to mitigate early edge loading using traffic control devices. Table 16 provides general guidance regarding opening strength and concrete thickness.

Table 16. Slab Thickness and Opening Strength

Slab Thickness (in.)	Strength for Opening to Traffic (psi)	
	Comp	Flex
6	3600	540
7	2700	410
8	2150	340
9	2000	300
10+	2000	300

Some agencies use rapid-strength concrete mixtures with a high cementitious material content, low w/cm ratio, and smaller top size aggregate (typically 0.75 in. [19 mm]).

These mixtures can be used with accelerating admixtures to provide the early strength required to place traffic on the overlay within a short time period. A water-reducing admixture is used to reduce the w/cm ratio and provide the desired workability properties.

Other Materials

Other materials that may be introduced to the mixture or used as part of the construction process include fibers, separation layers, dowels and tiebars, joint sealant, and curing compound.

Structural Fibers for Concrete Overlays

In general, the use of fiber reinforcement is not normally necessary for most concrete overlays. In certain situations, however—where, for example, vertical restrictions limit the overlay thickness, heavier-weight traffic loads are expected, increased joint spacing is desirable, or conventional dowels cannot be used—the use of fibers may be warranted.

During the last two decades, there has been resurgence in the use of fiber reinforcement in concrete; see Figure 91. The reason for this is when properly used, newer fiber-reinforcement technology can and does contribute to

FAQ—What are the concerns when using accelerated mixtures?

Mixtures that gain strength quickly and generate high heat of hydration have had long-term performance issues. There is a trade-off between early opening and long-term durability that needs to be evaluated when deciding whether or not to use an accelerated mixture. Accelerated opening can often be achieved through good construction scheduling and coordination, which negates the need for accelerated concrete mixtures. Thus, durability and speed of construction are factors that should be considered together during the design phase. In general, emphasis should be given to using conventional mixes whenever possible.

FAQ—Why do some accelerated mixtures have premature failures?

Accelerated mixtures typically have a higher potential for shrinkage and warping compared to a conventional mixture due to their higher paste content. Increased shrinkage and warping stresses at early ages can cause early cracking and can be detrimental to bond development, which will result in premature overlay failures.

the performance of thin concrete overlays. Whether the use of macro fiber in concrete overlays is warranted should be determined based on the existing pavement base thickness and condition, the owner's desired finish, the engineer's expected design life, overlay thickness, and cost. In appropriate dosages, fibers can perform the following functions in a concrete mixture:

- Help increase concrete toughness (allowing thinner concrete slabs)
- Help control differential slab movement caused by curling/warping, heavy loads,

temperatures, etc. (allowing longer joint spacing)

- Increase concrete's resistance to plastic shrinkage cracking (enhancing aesthetics and concrete performance)
- Hold cracks tightly together (enhancing aesthetics and concrete performance)

Although steel fibers have a long, successful history in paving applications, in the last two decades synthetic fibers have become predominant due to their ease of handling, better dispersion characteristics (i.e., less "balling"),



Figure 91. Synthetic fibers (1.5 in. to 2.25 in.)

and resistance to rust damage. Structural macro synthetic fibers (ASTM C-116 Type III, Section 4.1.3) are commonly used at 3 to 4 lb/yd³.

For current design technology, the dosage of fiber, whether synthetic, steel, or some blend, is specified to produce certain behavior characteristics in the hardened concrete. These characteristics correlate with forecasts of increased performance such as flexural strength, and hence fatigue capacity is enhanced. It should be noted that the actual strength of the concrete given the current technology increases only slightly, if at all. Concrete will still crack if the load exceeds that which can be borne mechanically at its upper strength limit, given the geometric properties of the section, but it will carry a much greater number of lesser loads up to that point and will continue to carry loads beyond that point. A simple analogy is to think of the concrete as being effectively stronger than that measured in a beam test; this effect varies as a function of dosage, not on weight, but by volume of fibers in the concrete mixture.

Table 17 provides a summary of current categories of fibers, with general descriptions and application rates. For a more detailed discussion of fibers, see Appendix C, Fiber Reinforcement.

Separation Layer Materials

A separation layer (or interlayer) is an important feature of unbonded concrete overlays on existing concrete pavements. The performance of these overlays depends largely upon using a separation layer to isolate the two concrete layers. All unbonded concrete overlays on concrete must be separated from the existing concrete pavement by a stress-relief layer, or separation layer, to prevent reflective cracking from movement of the existing pavement. The separation layer provides a shear plane that relieves stress and helps prevent cracks from reflecting up from the existing pavement into the new overlay.

Separation layers may serve three purposes:

1. Isolation from movement of the underlying pavement—a shear plane that relieves stress, mitigates reflective cracking, and may prevent bonding with the existing pavement
2. Drainage—the separation layer either must be impervious so that it prevents water from penetrating below the overlay or must channel infiltrating water along the cross slope to the pavement edge
3. Bedding—a cushion for the overlay to reduce bearing stresses and the effects of dynamic traffic loads and to prevent keying from existing faulting

Asphalt Separation Layer

Until 2010, the most common and successful separation layer used in the United States was a conventional asphalt mixture. On most projects, a nominal 1-in. (25-mm) thick layer provides adequate coverage over irregularities in the existing pavement. The thickness can be slightly increased when irregularities are large enough to impact placement operations. Asphalt mixtures that contain higher percentages of oil combined with smaller maximum nominal aggregate size have contributed to movement of dowel baskets during the paving operation because of concrete sliding on top of the asphalt separation layer. Typical base mixtures with lower oil content that do not seal up completely provide additional friction during the concrete placement operation, which may alleviate this condition.

The separation layer does not provide significant structural enhancement; therefore, the placement of an excessively thick layer should be avoided.

When an unbonded concrete overlay pavement is poorly drained and experiences heavy truck traffic, scouring (stripping) of the asphalt separation layer with a conventional asphalt mix may occur. In an effort to reduce the scour pore pressure and increase stability, some states modify the asphalt mixture to make it more porous. In particular, the sand content is reduced and the volume of 0.38 in. (10 mm) chip aggregate is increased. This modified mixture has a lower unit weight and lower asphalt content, and it is comparable in cost to typical surface mixtures. The Michigan DOT has designed an asphalt mixture with modified aggregate gradations to address stripping of separation layers; see Table 18.

Other materials have been utilized for separation layers; however, the performance of these materials has been inconsistent (for details on other separation layers, see Smith et al. (2002) and Rasmussen and Garber (2009).

Table 17. Summary of Fiber Types

Fiber Type	Size (D = dia.) (L = length)	Years Used in U.S.	Typical Fiber Volume (lb/yd ³)	Comments
Micro Synthetic Fibers	D < 0.012 in. (0.3 mm) L 0.50 to 2.25 in.	35	1.0 to 3.0	To reduce plastic shrinkage cracking and settlement cracking; limited effect on concrete overlay overall performance; more workability issues when using higher rates
Macro Synthetic Fibers	D > 0.012 in. (0.3 mm) L 1.50 to 2.25 in.	15	3.0 to 7.5	Increases post-crack flexural performance, fatigue-impact endurance; thinner concrete thickness; longer joint spacing; tighter joints, cracks; better handling properties, dispersion characteristics than steel fibers; not subject to corrosion
Macro Steel Fibers (carbon)	L 0.75 to 2.50 in.	40	33 to 100	Increases strain strength, impact resistance, postcrack flexural performance, fatigue endurance, crack width control per ACI 544.4R
Blended		15	Varies	Blend of small dosage of micro synthetic fibers and larger dosage of either macro synthetic fibers or macro steel fibers

Synthetic (polymer) fiber materials

- Polypropylene
 - Monofilament (cylindrical)—Fibers of same length
 - Multifilament—Monofilament fibers of different lengths
 - Fibrillated (rectangular)—Net-shaped fiber collated in interconnected clips
- Polyester
- Nylon

Table 18. Michigan DOT Asphalt Separation Layer Gradation

Sieve Size	Percent Passing
½ inch	100
¾ inch	85–100
No. 4	22–38
No. 8	19–32
No. 16	15–24
No. 30	11–18
No. 50	8–14
No. 100	5–10
No. 200	4–7

Nonwoven Geotextile Separation Layer

An alternative to an asphalt interlayer is a nonwoven geotextile interlayer; see Figure 92 (see also design details in Figures 88–90 on pages 73–74). The use of nonwoven geotextile fabric as an interlayer has been on the increase since 2010. The structural condition of the existing concrete pavement must be carefully assessed before selecting thin geotextile instead of a thicker asphalt interlayer, particularly when heavy faulting exists in the pavement to be overlaid.

According to Leykauf and Birmann (2006) of the Munich University of Technology, geotextiles have provided uniform, elastic support of

the concrete slabs, hence reducing stresses due to temperature and moisture gradient. They also reduce pumping processes and prevent origination of reflected cracks from bonded base courses without notching them.

Leykauf and Birmann (2006) also state that “concrete roads with a separation layer of geotextiles are especially recommended for concrete overlays on old concrete pavements, in tunnels and on rigid base courses.”

In colder weather (spring and fall) black-colored interlayer helps maintain a warmer temperature for the placement of the overlays because it has carbon molecules that absorb ultraviolet energy. This is not, however, desirable in hot weather conditions, particularly

when the fabric reaches 110°F or greater. Cooling the fabric with a water mist is then required under this condition. To prevent heat absorption, white-colored fabric has been developed recently to help reflect ultra-violet energy in hot and sunny weather; see Figure 93. In the fall or spring, however, white fabric is not the best choice to prevent heat transfer from the concrete overlay to the fabric.

Material specifications for a geotextile used as a separation layer for unbonded overlays are shown in Table 19. The weight/yd² and thickness should be given when specifying a geotextile interlayer. Following are two examples:



Figure 92. Geotextile separation layer (The Transtec Group [no date])



Figure 93. Light-colored geotextile fabric used as a separation layer for an unbonded overlay

Table 19. Geotextile Separation Layer Material Properties (Modified from Material Specifications (The Transtec Group [no date]))

Property	Requirements	Test Procedure
Geotextile Type	Nonwoven, needle-punched, no thermal treatment to include calendaring†	EN 13249, Annex F (Certification)
Color	Uniform/nominally same color fibers	(Visual Inspection)
Mass per unit area	≥ 450 g/m ² (13.3 oz/yd ²)* ≥ 500 g/m ² (14.7 oz/yd ²) ≤ 550 g/m ² (16.2 oz/yd ²)	ISO 9864 (ASTM D 5261)
Thickness under load (pressure)	[a] At 2 kPa (0.29 psi): ≥ 3.0 mm (0.12 in.) [b] At 20 kPa (2.9 psi): ≥ 2.5 mm (0.10 in.) [c] At 200 kPa (29 psi): ≥ 0.10 mm (0.04 in.)	ISO 9863-1 (ASTM D 5199)
Wide-width tensile strength	≥ 10 kN/m (685 lb/ft)	ISO 10319 (ASTM D 4595)
Wide-width maximum elongation	≤ 130 percent	ISO 10319 (ASTM D 4595)
Water permeability in normal direction under load (pressure)	≥ 1 x 10 ⁻⁴ m/s (3.3 x 10 ⁻⁴ ft/s) at 20 kPa (2.9 psi)	DIN 60500-4 (modified ASTM D 5493)
In-plane water permeability (transmissivity) under load (pressure)	[a] ≥ 5 x 10 ⁻⁴ m/s (1.6 x 10 ⁻³ ft/s) at 20 kPa (2.9 psi) [b] ≥ 2 x 10 ⁻⁴ m/s (6.6 x 10 ⁻⁴ ft/s) at 200 kPa (2.9 psi)	ISO 12958 (ASTM D 6574)* or ISO 12958 (modified ASTM D 4716)
Weather resistance	Retained strength ≥ 60 percent	EN 12224 (ASTM D 4355 @ 500 hrs exposure for grey, white, or black material only)
Alkali resistance	≥ 96 percent polypropylene/polyethylene	EN 13249, Annex B (Certification)

*Added to Material Specifications (The Transtec Group [no date]) for overlays

†Calendaring is a process that passes the geotextile through one or more heated rollers during the manufacturing process. The surface of the geotextile is modified during this process. Calendaring may reduce the absorption properties of the geotextile on the calendared side.

- ≤ 4 in. overlay—13.0 oz/yd² @ 130 mils (3.3 mm)
- ≥ 5 -in. overlay—15 oz/yd² @ 170 mils (4.3 mm)

Each highway agency is encouraged to develop their own weight and thickness criteria for geotextile interlayer based on their experiences and environmental conditions.

Dowel Bars and Tiebars

When needed for heavy traffic (typically pavement thickness of 7 inches or greater), dowel bars are usually billet steel, grade-60 bars that conform to ASTM A615 or AASHTO M31. The dowel bar size, layout, and coatings should be selected for the specific project location and traffic levels.

- Dowels should be nominally positioned in the middle third of the depth of the slab. Because of the variable thickness of concrete overlays, dowel placement at mid-depth is not always possible (guidance provided by Snyder [2011] states that load

transfer efficiency is adequate with a minimum of a 2-inch cover). Specify a single height basket for each nominal overlay thickness that will provide adequate cover.

- In some cases, because of the underlying support of the old pavement, dowels are not used in the overlay, or their size or numbers are reduced.
- Tiebars are typically billet steel, grade-40 bars that meet ASTM A615 or AASHTO M31 specifications. No. 4 or No. 5 (used for slab thickness ≥ 10 inches) deformed tiebars are typically spaced at 30 in. (76.20 cm) apart, but greater spacing may be used in some cases.

Joint Sealant

Joint sealant materials, if used, are either hot-poured rubberized materials conforming to ASTM D6690, AASHTO M301, or per normal design; silicone materials conforming to a governing state specification; or preformed compression seals conforming to ASTM

D2628, AASHTO M220, or a governing state specification. The need for seals depends on whether or not the design allows water to leave the pavement jointing system.

Curing Compound

White-pigmented liquid membrane-forming curing compounds (ASTM C309 or AASHTO M148) are recommended. Coverage should be at double the manufacturer's recommendations for all concrete overlays with a thickness of 6 in. or less.

Some agencies have implemented the use of curing compounds containing poly-alpha-methylstyrene (AMS) resin. Their use has been based on studies that have shown better moisture retention properties. Application methods and coverage rates are similar to normal white-pigmented curing compounds. A typical material specification for AMS curing compound can be found at www.dot.state.mn.us/products/concrete/pdf/curing_compound_specifications_3753_3754_3755.pdf.

Chapter 6.

CONCRETE OVERLAY STRATEGIES IN WORK ZONES

This section discusses several issues related to work zone management, including clearances, traffic control, and staging. By their nature, concrete overlays are accelerated projects because demolition, excavation, and base work are not necessary. In short, concrete overlays can be executed in the same manner

as other resurfacing projects have been for decades. This section provides guidance on specific details for optimizing constructibility of the concrete overlay and maintaining traffic. See Appendix E for more information about constructing overlays under traffic.

Objectives of Work Zone Management

A checklist of considerations in overlay work zone management is provided in Table 20.

Table 20. Concrete Overlay Work Zone Management Considerations

Areas of Consideration	Items to Consider	
Traffic Management	<ol style="list-style-type: none"> 1. Capacity analyses—lanes required, length of queues anticipated 2. Time restrictions—peak hours, seasonal peaks 3. Limits to work areas 4. Capacity of detour routes 5. Work vehicle access and worker parking 6. Bicycle and pedestrian traffic 	<ol style="list-style-type: none"> 7. Warning sign locations—detours, long queues, intersecting roads 8. Railroad crossings and train schedule 9. Nighttime delineation and illumination 10. Signals, turning lanes, bus stops 11. Traffic service—residential/business 12. Future rehabilitation
Concrete Pavement Construction Requirements	<ol style="list-style-type: none"> 1. Accelerated construction—planning, concrete materials, construction requirements, curing, jointing 2. Opening to traffic—maturity, pulse velocity, strength requirements, cure time 3. Rehabilitation considerations 4. Off-peak traffic hours for increased production 5. Phasing of work—length of work zone, project limits 6. Special conditions such as dropoffs, sign bridge installation, etc. 	<ol style="list-style-type: none"> 7. Prepaving and paving restrictions 8. Special contract provisions needed 9. Short-duration closures anticipated 10. Temporary drainage 11. Lights for night work 12. Temporary roadway lighting
Safety	<ol style="list-style-type: none"> 1. Work zone crash rates 2. Traffic management strategies 3. Interstate system 4. Congestion 5. Nighttime 	<ol style="list-style-type: none"> 6. Large trucks 7. Workers on foot 8. Pedestrians 9. Local experience
Constructibility	<ol style="list-style-type: none"> 1. Structural capacity of bridges, shoulders, and pavement 2. Timing of phases versus probable starting date 3. Strategy to allow contractor to finish project 4. Status of existing traffic control devices—signals, signs, railroad crossings, etc. 5. Wintertime restrictions—snow removal, etc. 	
Emergency Planning	<ol style="list-style-type: none"> 1. Incident management plans 2. Emergency medical assistance 3. Accidents, breakdowns, tow trucks 4. Severe storms and storm-water runoff 	<ol style="list-style-type: none"> 5. Emergency closures 6. Utility interruptions 7. State police 8. Local law enforcement
Public Information Coordination	<ol style="list-style-type: none"> 1. Public information—public hearings, media, motorist service agencies, residents, local businesses, motor carriers 2. Local officials—police, fire, hospitals, schools, environmental agencies, utilities, toll facilities, ferries, railroads, airports 3. Special events 4. Intra-agency coordination—maintenance crews, permits section, adjacent project 5. Transit 	

Managing work zones for concrete overlay projects is no more challenging than for any other paving project under traffic, as long as certain straightforward practices are followed.

Effective work zone management for all concrete pavement projects, including concrete overlays for maintenance and rehabilitation, involves designing a comprehensive plan of action that balances several equally important priorities; see Figure 94:

- Ensure safety of workers and motorists
- Minimize inconvenience to the traveling public
- Maintain or enhance cost effectiveness of the project
- Balance maintenance of traffic concerns with long-term pavement performance

The basic elements of these priorities are discussed below. A checklist of considerations in overlay work zone management is provided in Table 20.

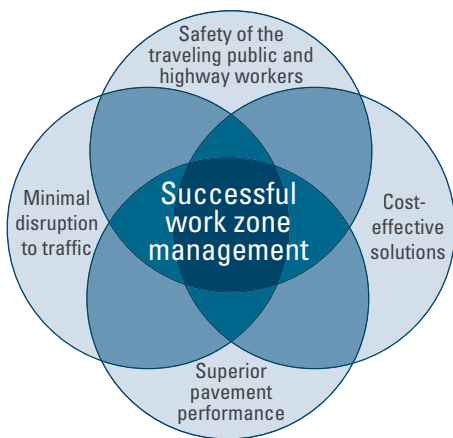

Figure 94. Managing work zones effectively involves balancing several priorities

Safety

Promoting worker and traveler safety should be an integral, high-priority element of every project, from planning through construction. Roadway users (vehicles, bicycles, pedestrians, etc.) must be clearly guided by traffic control devices and markings while approaching, passing through, and leaving temporary traffic control zones. Traffic control elements should be regularly inspected. All people involved in selecting, placing, and maintaining work zones should be trained in safe traffic control practices.

The exposure of highway workers and travelers to traffic risks can be minimized by reducing the frequency with which work zones are established, reducing the length of time work zones are in place, and, where possible, reducing the volume of traffic through the work zone. When compared to reconstruction options, concrete overlays have a significantly shorter construction duration, which reduces public and construction worker exposure.

A detailed emergency response plan should be in place to deal with any injury that might occur in the work zone. The plan should include protocols for emergency medical services.

Traffic Flow

Minimizing disruption to traffic in work zones requires a proactive, partnership approach to work zone management. By involving officials and the public during early stages of project planning, the designer and contractor can gain a better understanding of traffic issues related to the project. As a result, they can develop better, more coordinated solutions. In addition, broadly publicizing the work zone well before construction begins helps ensure that motorists have every opportunity to plan travel routes and times accordingly.

Cost Effectiveness

Strategies used to manage traffic in work zones can significantly affect project costs. Therefore, it is important to carefully evaluate road use demands and select the most cost-effective strategies to accommodate the demands. Traffic control costs and construction costs should be balanced against the impact on the public, especially adjacent businesses and residents. In many cases, a short full-road closure has far less impact than maintaining traffic through a construction zone for extended durations.

Many urban intersections have been overlaid with concrete utilizing only weekend work hours, which has mitigated the impact on surrounding businesses.

Partly or completely closing a work zone to traffic can help minimize traffic management costs. Informal project reviews that have been performed on constructed concrete overlay projects utilizing pilot car operations indicate that there could have been an approximate 20 to 30 percent cost and time savings had the roadway been closed to through traffic. If closing the roadway to through traffic is a viable option, the contract documents should clearly state that the contractor is responsible for maintaining local access for residents and businesses. Putting the onus on the contractor, yet allowing flexibility in their methods for providing local access, is a preferred strategy rather than explicit details regarding how and when the access shall be maintained. When a roadway cannot be closed, higher costs are probably justifiable. Potential ways to manage costs include, where possible, reducing traffic volume through work zones, reducing the frequency and duration of work zones, and minimizing detours and crossover construction elements. For long (> 7 miles) two-lane overlay projects, allowing for multiple work zones simultaneously can improve construction operation efficiencies and cost effectiveness.

Work Zone Space Considerations

Constructing any overlay requires occupying some part of the traveled portion of the roadway to accommodate work activities and provide traffic control and other safety provisions for workers and motorists. This will affect traffic capacity through the work zone for the duration of the work activities. In some cases, safety considerations may require partial or even complete closure of the roadway.

When overlay projects are constructed under traffic, space and traffic capacity considerations impact three primary elements of a work zone management strategy: construction clearances, traffic control, and project staging.

Conventional Paving Equipment Clearances

When work zones are set up under traffic, adequate clearance must be provided to accommodate the paving machine's tracks and frame, as well as the paving stringline. For a standard concrete paver operation, the typical paving equipment clearance is 4 ft (1.2 m) on each side of the paving machine (3 ft [0.9 m] for the paver track and 1 ft [0.3 m] for the paver control stringline); see Figure 95. Paving equipment clearances do not include space for traffic control devices or workers or space for highway users (vehicles, pedestrians, bicycles, etc.). Additional clearances needed should be determined on a project-by-project basis.



Figure 95. Stringline paver

Reducing Clearances

In some situations—narrow roadways, minimum or no shoulders, traffic in adjacent lanes, obstacles like retaining walls or safety barriers—paving equipment clearances may need to be reduced. These situations are fairly common with all maintenance and rehabilitation projects. With adequate planning, zero paving equipment clearance can be achieved to accommodate specific project needs, such as paving next to a median barrier; see Figure 96. (As with asphalt paving, zero paving equipment clearance in concrete paving does not include the 6–8 in. [150–200 mm] for the paving machine edge form.)

Two-lane roads with wide (8–10 ft [2.4–3.1 m]) shoulders of granular or stabilized base will allow room for pilot car traffic and two lanes of construction traffic. The use of

stringless paving technology can reduce the clearance required for paving equipment to 3 ft (0.9 m). It also allows the traffic cones to be placed at the edge of the new lane directly behind the texture/cure operations, which maximizes the width of the existing lane for pilot car operations.

Paving machine manufacturers have developed special paving machines designed to execute minimum clearance projects. In addition, many contractors around the country have made various modifications to standard pavers to achieve zero clearances; see Figure 97.

Instead of specifying a certain manufacturer's machine, owner-agencies are advised to define the maximum allowable clearance zone and let the contractor select or modify the equipment and operation to meet project needs.



Figure 96. A three-track, zero-clearance paver placing concrete along a median barrier (source: Kevin Klein, Gomaco)



Figure 97. A typical four-track paver modified to three tracks, providing zero clearance in a C/G situation in Oklahoma (source: Jim Duit, Duit Construction Co., Inc.)

Mechanical Methods

Alternative paving control options may be used to reduce clearance as long as smoothness criteria are met. For example, an average profiler, a movable stringline, or a ski can be used in tight areas, each relying on the smoothness of an existing lane to ensure a smooth profile on the new pavement; see Figures 98 and 99.

Stringless Methods

Several companies have developed stringless equipment control and guidance systems using technologies such as GPS, robotic total stations, and laser positioning. Stringless technology replaces the traditional stringlines with an electronic tracking process that controls the horizontal and vertical operation of the slipform paver. The construction industry has been using stringless technology for elevation and steering control of equipment for a number of years. Stringless paving, however, is now an emerging technology for concrete paving because it can allow contractors and owner/agencies to receive production benefits

(e.g., reduced survey costs, fewer construction hours) while still meeting smoothness requirements. Details regarding various stringless paving systems are provided in Appendix F.

Stringless paving is a technology that eliminates the installation and maintenance of stringlines and has the potential to decrease the need for surveying and increase the smoothness of the pavement profile; see Figures 100 and 101. Any technology problems can arise, however, and lessons learned can take time and may cause delays. Field research on stringless paving was first started in 2003 by the National Concrete Pavement Technology Center at Iowa State University (Cable et al. 2004).

The benefits that can result from stringless paving include the following:

- Reduced construction costs. The stringless systems eliminate the need for stringline crews to place, maintain, and remove stringlines. The stringless system requires the survey crew to establish the project reference points but removes the need to place

paving reference hubs or pins at 12- to 50-foot intervals. Surface surveys are now conducted by one- to two-person crews versus three to four persons. Typically, these persons are replaced by one surface modeler and two persons to establish laser, total station, or GPS base stations on the project.

- Reduced time and manpower. Surface and reference point surveys are now conducted in much less time and with reduced manpower. Many highway agencies do not have the manpower or time to conduct stringline operations, but they can prepare for the stringless control operation.
- Construction access. Removal of the stringlines opens up the site to both the contractor and/or adjacent public. No longer must the contractor worry about damage to the stringline during construction or the workers tripping over the stringline. Construction vehicles can enter and leave the site at any location without fear of stringline damage.



Figure 98. Controlling paving profile using a moveable stringline on the adjacent lane (source; Kevin Klein, Gomaco)



Figure 100. Stringless paver (source: Jim Cable, Iowa State University)



Figure 99. Controlling paving profile using a paver ski on the adjacent lane (source: Wouter Gulden, southeast chapter, ACPA)



Figure 101. Zero clearance stringless paver (source: GOMACO)

- Public access. Those living along the construction site can enter and leave their residence or business at all times except during the actual pavement placement and curing time without concern for stringline interference.
- Urban and rural application. No longer must the contractor and highway agency be concerned about narrow roadway tops, ground-level vegetation, or earthwork that limits the location of the stringline or operation of both it and the paver.

Other Clearances

In addition to paving equipment clearances on all construction operations, clearance must be allowed for traffic control devices and construction workers. The width of this clearance zone varies depending on adjacent traffic volume, traffic speed, and agency requirements. In addition, the location of workers with long-handled floats should be restricted to the nontraffic side of the pavement.

Construction Traffic Control

All work zone traffic control, including speed restrictions, should follow jurisdictional requirements and the latest *Manual on Uniform Traffic Control Devices* (FHWA 2009). The fundamental principles of work zone traffic control are given in Part 6. In addition, the *Traffic Management Handbook for Concrete Pavements Reconstruction and Rehabilitation* (ACPA 2000) is a good reference on traffic control strategies for common roadway rehabilitation categories, including overlays. See, in particular, Chapter 4 on traffic control strategies for concrete pavement.

The ACPA handbook explains that “as traffic volumes increase, the ‘window’ of time where the traffic demand is below the capacity of the work zone will become smaller. When the time is too short to allow for daytime work, the work is usually moved to nighttime. In some cases even the nighttime hours are restricted.”

For situations such as recreational routes, the peak traffic hours may be on Friday and Sunday afternoons. The allowable window of time for road construction in this case may be noon Monday to 6:00 p.m. Thursday.

For roadways under high traffic demands, a traffic analysis should be conducted to identify which parts of the roadway can be occupied by construction and public traffic at any point during the construction time period. The goal is to identify congestion points that could affect traffic capacity and safety as well as construction production levels.

Such an analysis answers specific questions:

- Is the capacity of the existing roadway adequate for existing traffic levels?
- How will capacity be affected if some lanes are shut down and other lanes kept open?
- Comparing existing traffic levels to the under-construction capacity, are there any capacity deficiencies?

The analysis should consider both the lateral clearance (availability and need) and the length of roadway needed to provide efficient, cost-effective paving production. It must also factor in peak and off-peak traffic flows.

If deficiencies will occur, the work zone management plan must address them to prevent congestion and increased project costs. For example, the plan might include variable work times (e.g., off-peak hours, nighttime) or construction sequencing to meet production and safety demands.

An increasingly popular alternative is to completely close the facility briefly to complete the project or a critical phase of the project. In some cases, this alternative has reduced the overall project duration significantly.

Concrete Overlay Staging

Many easy-to-use approaches exist for staging concrete overlay projects in almost any situation. A system approach that considers work zone safety, traffic requirements, and key elements of construction should be used in staging concrete overlay plans for fast, cost-effective construction projects. When construction acceleration is desired, it should begin in the design phase with an analysis of alternative maintenance of traffic schemes, advance planning, and tailoring of project details to facilitate shortened construction durations. The plans and specifications should provide the contractor with clear criteria for maintenance of traffic requirements (e.g., two lanes open in each direction at all times, pilot car queues shall not exceed 10 minutes, etc.). Given the requirements for maintenance of traffic, the contractor should be given the responsibility to plan and prosecute the project to meet the objectives for accelerated construction and maintenance of traffic. This approach of allowing the contractor to innovate and plan the project to meet their resources results in more efficient workflow, shorter durations, and less impact on the road users.

Some common staging scenarios are described below.

Two-Lane Highway under Traffic

When construction will be completed under traffic and certain lanes need to carry additional traffic, various options regarding preoverlay spot repairs should be considered. For example, if spot repairs can be made quickly (and, if appropriate, a separation layer can be placed immediately after the repairs), then it is normally acceptable to put temporary additional vehicle traffic on the existing pavement until the overlay is constructed. Another option is to wait and make final spot repairs after the temporary additional traffic is moved off the existing pavement. This approach should be used only when the extent of additional repairs needed, the additional thickness of overlay required, and related costs are clearly understood. Alternatively, it is possible to temporarily close the roadway (preferably during off-peak hours), make the critical repairs and complete the overlay at least on one lane, and open it to traffic as soon as possible.

When staging a two-lane concrete overlay project under traffic, the widths of the vehicle lane and the construction lane must be considered. Typically, the minimum desirable width for the vehicle lane is 11 ft (3.4 m). Some jurisdictions may allow as little as 10 ft (3.1 m) under certain circumstances—for example, in very short segments (less than 100 ft [30.5 m]).

The width of the construction lane depends on several factors, including thickness of overlay, maximum allowable centerline dropoff or edge fillet, slope of fillet, type of traffic control device, type of paving machine, and automobile and truck traffic.

Concrete overlays can be successfully constructed under traffic with conventional paving machines; in some cases, where minimum clearances are required, minor adjustments may be necessary.

The length of the temporary traffic control zone is another important factor. Typically, when the length of traffic control zones is less than 0.25 mi (0.40 km), a pilot car is not used. In rural areas, however, it may be more feasible to pave longer sections. In such situations, a pilot car and flaggers are often used and the maximum length of the traffic control zone is established by the jurisdiction.

Other traffic control measures, including flaggers and traffic control signals, may be warranted according to jurisdictional requirements.

When granular shoulders of adequate widths are available to accommodate a conventional paver, it is recommended that the shoulders be treated with calcium chloride (3 ft [0.9 m]

wide) before opening the road to vehicular traffic. The calcium chloride treatment is a successful way of stabilizing the shoulder in case errant vehicles leave the pavement. Also, vertical traffic control panels or a permanent safety edge may be used to designate the pavement edge; see Figure 102.

If shoulder paving is part of the project, the trenching of paved shoulder base widening should be completed in the first stage along with surface preparation of the initial lane to be overlaid. Once this is completed, this lane can be opened to traffic and the adjacent lane can be prepared for paving.

During the second stage, the second lane is paved. A thickened edge may be paved if pavement widening is part of the project.

The third stage includes opening the newly placed overlay to traffic and shifting traffic control for work on the opposite lane. The final stage includes placing pavement markings, rumble strips if shoulders are paved, and final shouldering.

Temporary Safety Fillet

If two-way traffic is desired on the roadway after the first lane is cured, and agency-established dropoff criteria require a dropoff mitigation, construction of temporary centerline and outside safety fillets may be an option; see Figure 103. An outside safety edge fillet should be considered if shouldering will not be completed before opening the roadway to traffic.

Pilot Cars for Continuous Production

Pilot cars can be used to keep one lane of traffic adjacent to the paving operation open at all times. To minimize traveler delays, many jurisdictions limit the length of such work zones. Contractors must balance those limitations with their need for continuous production so that crews do not stand idle at any time.

The following are some considerations for staging a project using pilot cars cost effectively:

- Typically, a contractor can prepare and pave 2,500 yd³ (1,911 cm) in one lane per working day. For thinner overlays, the rate of the sawing operation may be the limiting factor on production.
- Constructing an edge fillet may make it possible to open the lane to traffic before the shoulder backfill is completed.
- A new overlay can be opened in 24 hours or less.
- Leaving gaps in or staggering construction areas (that is, leapfrogging over a section of pavement) can allow the contractor to stage work in ways that use crews and machinery more efficiently.
- Using multiple paving machines may make it possible to stagger work zones more efficiently.
- The direction of the initial pour is important to make sure the paver ends each pour in the optimum position to begin the next.

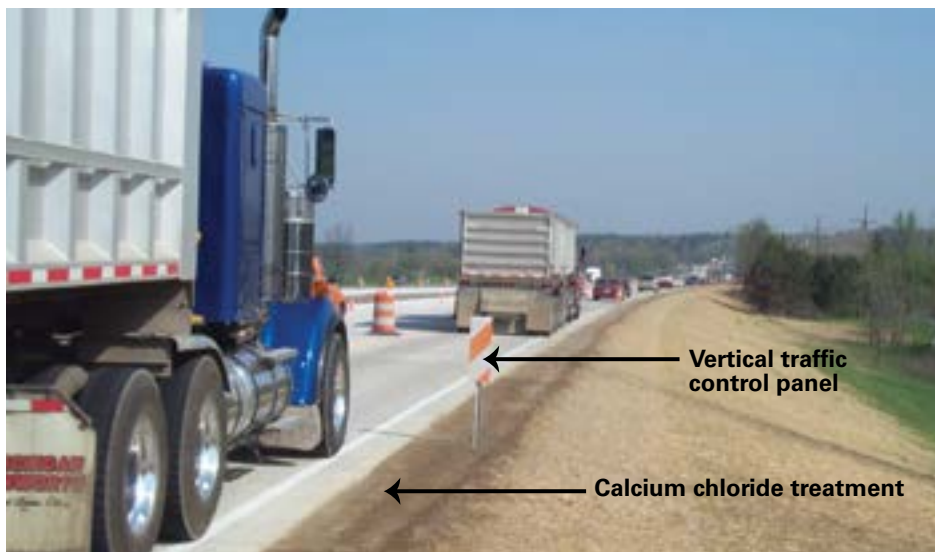

Figure 102. Vertical traffic control panels may be used to mark pavement edge dropoff (source: Dan DeGraaf, Michigan Concrete Paving Association)

Examples of Staging Sequences

Figures 104–108 on pages 88–97 illustrate a variety of potential staging sequences. Note that each half of a four-lane divided highway is treated like a two-lane section.

Two-Lane Highway Expanded to Three Lanes under Traffic

When constructing a concrete overlay and widening a pavement from two lanes to three lanes, some states require that the remaining shoulder after pavement widening be at least 4 ft (1.2 m) wide. Therefore, using both existing shoulders for staging and widening has distinct advantages.

First, base shoulder widening on one-half of the road is accomplished. The overlay is constructed in halves similar to the two-lane

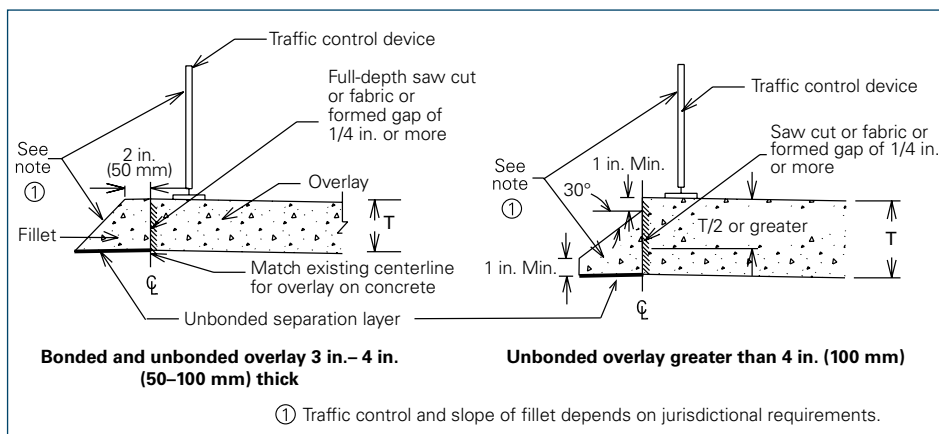

Figure 103. Centerline safety edge fillets for overlays 3 in. (50 mm) or greater

staging example. The existing shoulder is trimmed and properly compacted. The first concrete overlay section is then placed with a thickened edge. The other half of the overlay can be placed directly on top of the base shoulder constructed first.

A possible staging sequence for this type of construction management is shown in Figure 107.

Four-Lane Divided Highway without Crossovers and under Traffic

Staging a concrete overlay on a four-lane divided highway is similar to that on a two-lane highway. Both two-lane sides may be under construction at the same time, and crossovers are eliminated. By eliminating crossovers, project costs are reduced and safety

is increased. The existing shoulders usually provide adequate room for the paver track, stringline, and workers between the paver and traffic.

A possible staging sequence for this type of construction is shown in Figure 108. Because each half of the four-lane divided highway is treated like a two-lane section, any of the staging sequences from Figures 104–107 may be used on either half of the section.

COMPLETED OVERLAY (Two-Lane Roadway with Paved Shoulders, Conventional Paver)**Applied to:**

- | | |
|--|--|
| <input checked="" type="checkbox"/> Bonded concrete overlay of concrete pavements | <input checked="" type="checkbox"/> Unbonded concrete overlay of concrete pavements |
| <input checked="" type="checkbox"/> Bonded concrete overlay of asphalt pavements | <input checked="" type="checkbox"/> Unbonded concrete overlay of asphalt pavements |
| <input checked="" type="checkbox"/> Bonded concrete overlay of composite pavements | <input checked="" type="checkbox"/> Unbonded concrete overlay of composite pavements |

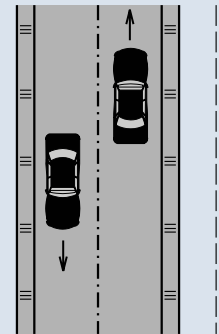
**STAGE 1.****Repair surface, prepare for overlay, and construct base shoulder widening and separation layer**

- Install traffic control and close the left lane. Follow jurisdictional requirements for traffic control. Check with jurisdiction regarding allowable lane closure length. If surface repair and preparation for the overlay are minimal, then slow-moving traffic control may be appropriate. Closing the lane may require additional traffic control (e.g., signals, flaggers, and/or pilot cars).
- Repair the surface as appropriate. Prepare the surface for the overlay (or, in the case of concrete overlay on concrete, the separation layer) as described in the contract document.
- Prepare for shoulder widening by trenching the existing shoulder and trimming to the specified width. The trench should be rolled and compacted as necessary to obtain a firm and stable platform as specified in the contract documents. A continuous progression approach with the shoulder trencher and placement of the base shoulder widening material is encouraged.
- Construct separation layer (only for unbonded overlay on concrete).

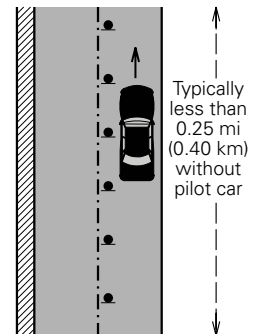
**STAGE 2.****Construct right shoulder and concrete overlay**

- Shift the traffic control to the left lane and close the right lane to traffic. The length of the closure will depend on the jurisdiction's maximum closure length with pilot car. Traffic controls and traffic control signals will be based on jurisdictional requirements.
- Repair and prepare the surface for the overlay or the separation layer and subsequent overlay as described in the contract documents. Construct separation layer (for unbonded overlay).
- Normal space for the paver stringline is 1–1.50 ft (0.30–0.46 m) and the paver track is a minimum of 2.50–3 ft (0.76–0.91 m). 1 ft (0.3 m) incremental encroachment reduction (up to 2 ft (0.6 m) total) is common through typical machine adjustment. Speeds should be additionally restricted adjacent to paver when clearance between the paver and vehicle traffic is tight.
- Construct concrete overlay on the existing pavement. Complete right PCC shoulder widening with the overlay. Bull float work shall operate from the outside shoulder only.
- The "X" dimension between the roadway centerline and vertical panel is for the paving machine track and stringline.

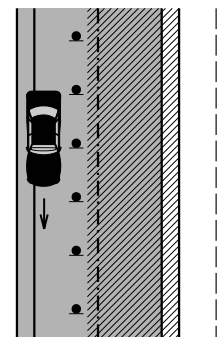
**STAGE 3.****Construct left lane concrete overlay**

- Close the opposite lane to traffic and place the concrete overlay according to contract documents, using the same procedures as described in stage 2. Note that stringline may not be necessary for the right edge of the paving when the paved overlay constructed in stage 2 is used as the paver control in this stage. If the right stringline is not used, the "X" dimension could possibly be reduced to 3 ft (0.9 m).
- If the outside edge dropoffs at the shoulder exceeds the jurisdictional allowance for a 1:1 fillet, then construct the granular shoulders in this stage.
- Complete shouldering. Install (mill) rumble strips in the paved shoulders and complete pavement marking and regulatory signing in accordance with contract documents.

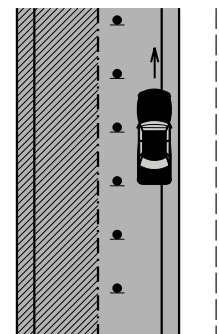
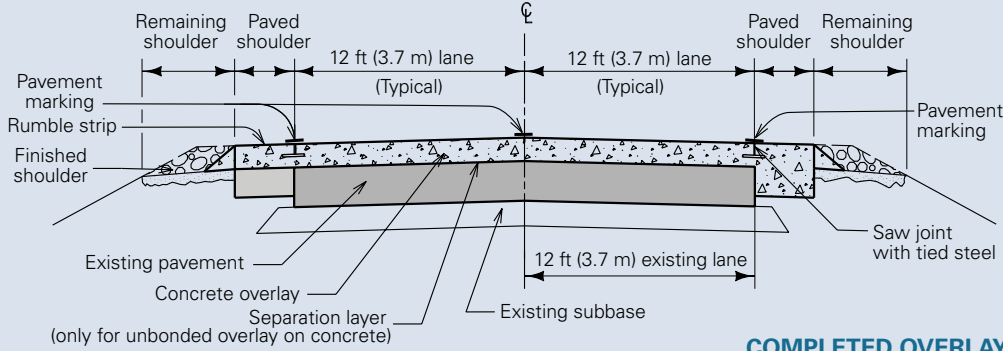





Figure 104. Overlay of two-lane roadway with paved shoulders (conventional paver)



COMPLETED OVERLAY

LEGEND

-  Stage work area
-  Concrete
-  Base shoulder widening materials (e.g., cement-treated base, porous concrete, roller compacted concrete (RCC), asphalt, or concrete)
-  Granular material

NOTES:

- ① Follow jurisdictional requirements for traffic control devices.
- ② Treat 3 ft (0.9 m) area outside of proposed paved shoulder with calcium chloride. If the existing shoulder outside the proposed paved shoulder is less than 3 ft (0.9 m), it may be necessary to adjust the slipform paver and/or paver control to accommodate the reduced space.
- ③ Minimum lane width next to the paver may be reduced for short-term, stationary work on low-volume, low-speed roadways when vehicular traffic does not include longer and wider heavy commercial vehicles.
- ④ If the overlay is opened to traffic in this stage, and final shoulder backfill is delayed, place fillet as shown or (if overlay creates a dropoff greater than jurisdictional allowance) place granular shoulder.
- ⑤ See centerline fillet illustration and subsequent removal on figure 103.
- ⑥ For "X" less than 4 ft (1.2 m), adjustments to paver may be necessary to accommodate paver control and paver track.
- ⑦ The "X" dimension can be reduced to 3 ft (0.9 m) minimum when the right lane is used as paver control.
- ⑧ Mark edgelines and centerlines per MUTCD (FHWA 2009) section 6F.77 (mark both lanes).
- ⑨ Construct longitudinal joint.

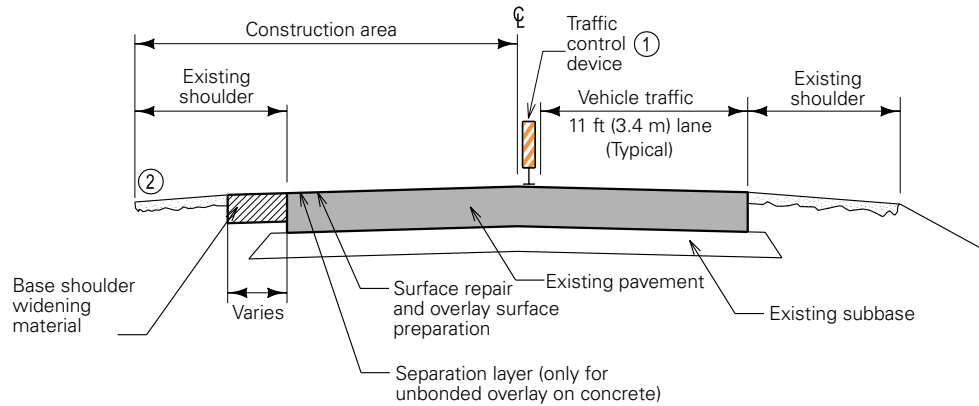

STAGE 1

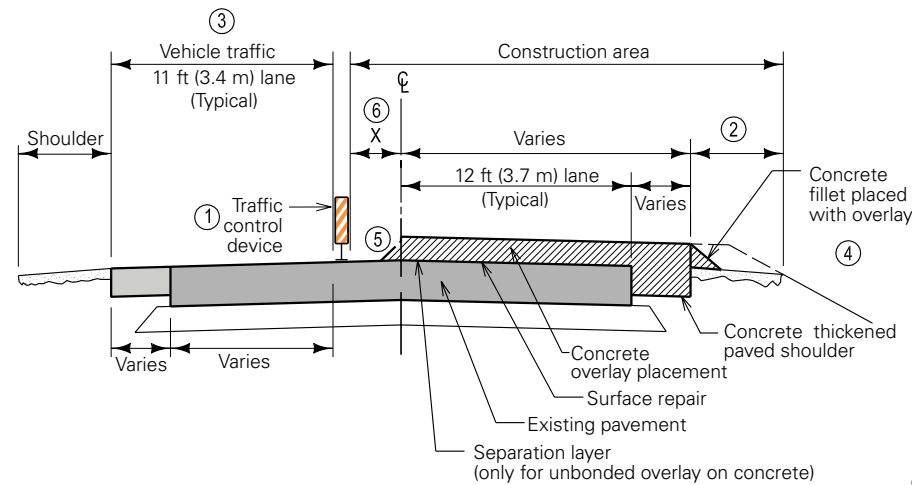

STAGE 2

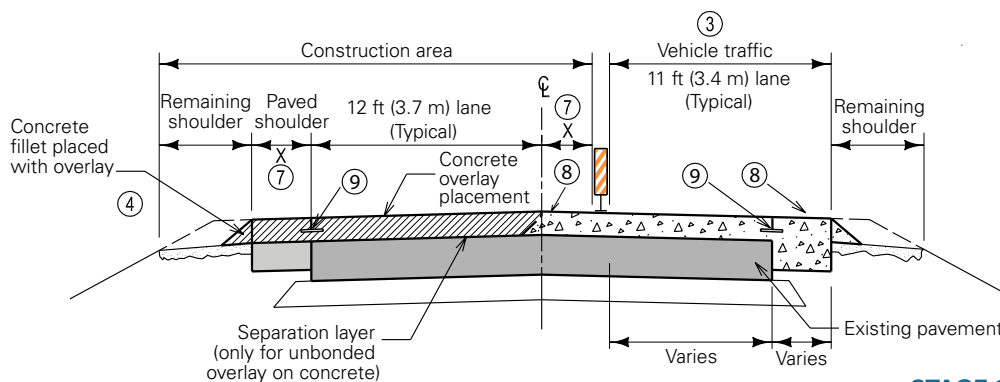

STAGE 3

Overlay of Two-Lane Roadway with Paved Shoulders (Conventional Paver)

COMPLETED OVERLAY (Two-Lane Roadway with Granular Shoulders, Conventional Paver)

Applied to:

- Bonded concrete overlay of concrete pavements
- Bonded concrete overlay of asphalt pavements
- Bonded concrete overlay of composite pavements
- Unbonded concrete overlay of concrete pavements
- Unbonded concrete overlay of asphalt pavements
- Unbonded concrete overlay of composite pavements

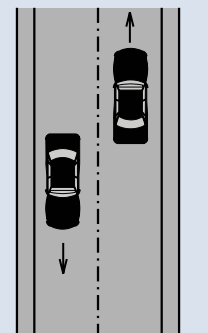

STAGE 1.

Repair surface, prepare for overlay, and construct left shoulder and separation layer

- Install traffic control and close the left lane. Follow jurisdictional requirements for traffic control. Check with jurisdiction regarding allowable lane closure length. If surface repair and preparation for the overlay are minimal, then slow-moving traffic control may be appropriate. Closing the lane may require additional traffic control (e.g., signals, flaggers, and/or pilot cars).
- Repair the surface as appropriate. Prepare the surface for the overlay (or, in the case of concrete overlay on concrete, the separation layer) as described in the contract document.
- Prepare shoulder widening by trenching the existing shoulder and trimming to the specified width. The trench should be rolled and compacted as necessary to obtain a firm and stable platform. Compact shoulder material as specified in the contract documents. A continuous progression approach with the shoulder trencher and placement of the base shoulder widening is encouraged.
- Construct calcium chloride treated granular shoulder as outlined in contract documents. The treated shoulder shall be firm and stable to support vehicular traffic at low speeds.
- Construct separation layer (only for unbonded overlay on concrete).

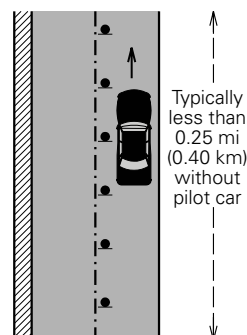

STAGE 2.

Construct right shoulder and concrete overlay

- Shift the traffic control to the left lane and close the right lane to traffic. The length of the closure will depend on the jurisdiction's maximum closure length with pilot car. Traffic controls and traffic control signals will be based on jurisdictional requirements.
- Repair and prepare the surface for the overlay or the separation layer and subsequent overlay as described in the contract documents. Construct separation layer (for unbonded overlay on concrete).
- Normal space for the paver stringline is 1–1.5 ft (0.3–0.5 m) and the paver track is a minimum of 2.5–3 ft (0.8–0.9 m). 1 ft (0.3 m) incremental encroachment reduction (up to 2 ft [0.6 m] total) is common through typical machine adjustment. Speeds should be restricted adjacent to paver when clearance between the paver and vehicle traffic is limited.
- Construct concrete overlay on the existing pavement. Construct right shoulder base with 6 in. (150 mm) thick granular shoulder. Bull float work shall operate from the outside shoulder only.
- Place 6 in. (150 mm) minimum thickness calcium chloride treated granular shoulder to help stabilize shoulder and minimize heavy dust that can impair vision.
- The "X" dimension between the roadway centerline and vertical panel is for the paving machine track and stringline.

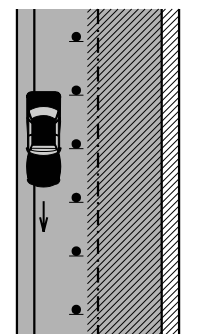

STAGE 3.

Construct left lane concrete overlay

- Close the opposite lane to traffic and place the concrete overlay according to contract documents, using the same procedures as described in stage 2. Stringline may not be necessary for the right edge of the paving when the paved overlay constructed in stage 2 is used as the paver control in this stage. If the right stringline is not used, the "X" dimension could possibly be reduced to 3 ft (0.9 m).
- If the outside edge dropoffs at the shoulder exceeds the jurisdictional allowance for a 1:1 fillet, then construct the granular shoulders in this stage.
- Complete shouldering. Complete pavement marking and regulatory signing in accordance with contract documents.

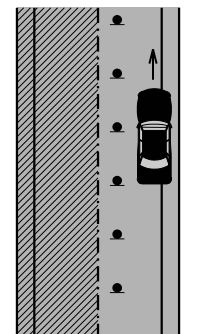
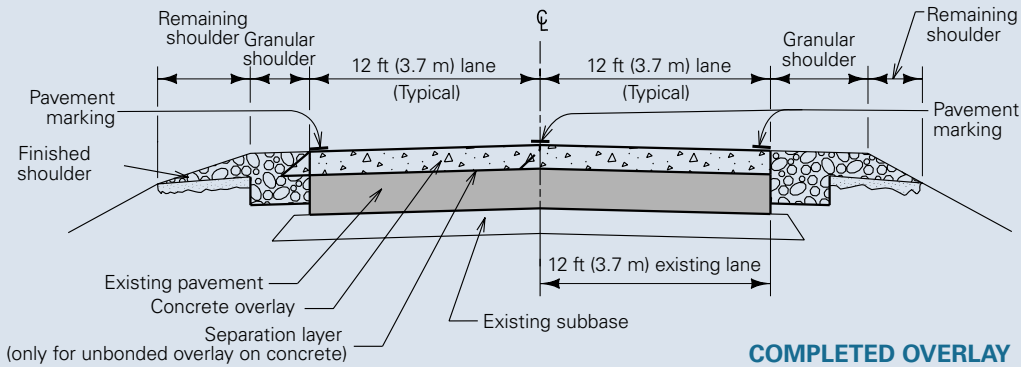

Figure 105. Overlay of two-lane roadway with granular shoulders (conventional paver)



LEGEND

	Stage work area
	Concrete
	Granular material

NOTES:

- ① Follow jurisdictional requirements for traffic control devices.
- ② When the existing shoulder is less than 4 ft (1.2 m), adjustment to the slipform paver and/or paver control may be necessary to accommodate the reduced space for paver control and paver track.
- ③ Minimum lane width next to the paver may be reduced for short-term, stationary work on low-volume, low-speed roadways when vehicular traffic does not include longer and wider heavy commercial vehicles.
- ④ If the completed overlay in this stage opens to traffic and the final shoulder backfill is delayed, place fillet as shown. If overlay creates a dropoff greater than jurisdictional allowance, place granular shoulder in lieu of concrete fillet.
- ⑤ See centerline fillet illustration and subsequent removal on figure 103.
- ⑥ For "X" less than 4 ft (1.2 m), adjustments to paver may be necessary to accommodate paver control and paver track.
- ⑦ The "X" dimension can be reduced to 3 ft (0.9 m) minimum when the right lane is used as paver control.
- ⑧ Mark edgelines and centerlines per MUTCD (FHWA 2009) section 6F.77 (mark both lanes).
- ⑨ Use calcium chloride for dust control.
- ⑩ For low-volume roads only

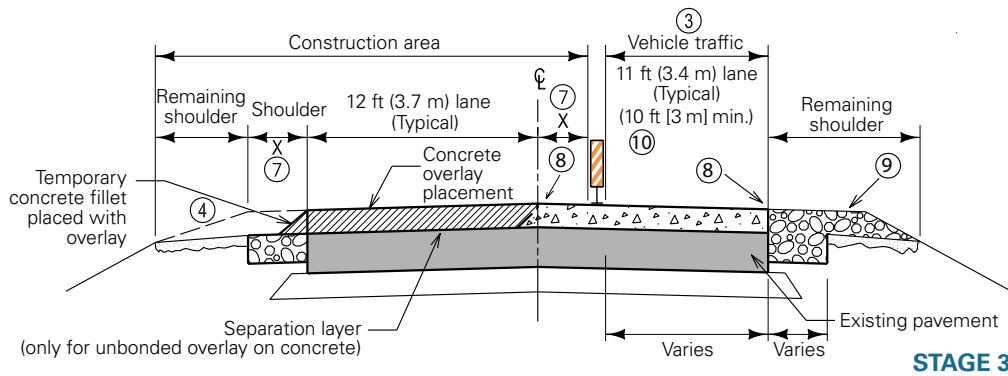
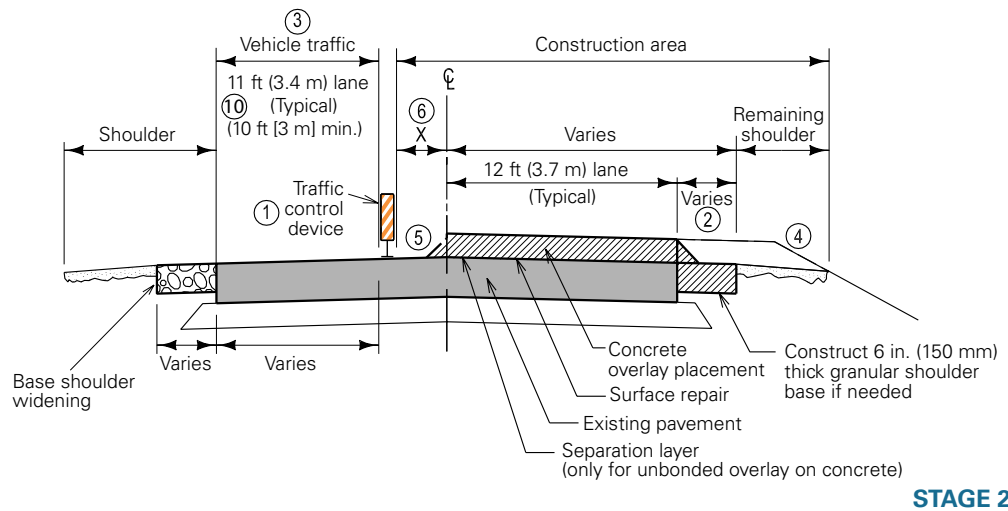
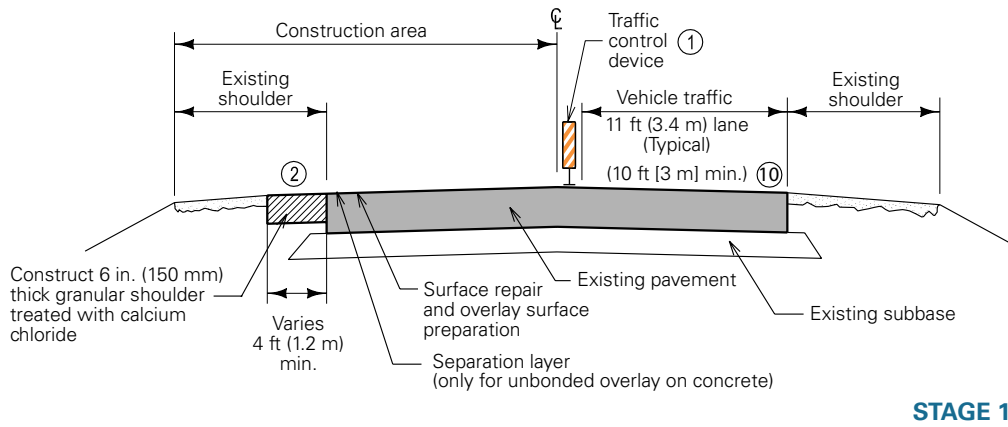

Overlay of Two-Lane Roadway with Granular Shoulders (Conventional Paver)

COMPLETED OVERLAY (Two-Lane Roadway with Minimum Granular Shoulders, Zero-Clearance Paver)

Applied to:

- Bonded concrete overlay of concrete pavements
- Bonded concrete overlay of asphalt pavements
- Bonded concrete overlay of composite pavements
- Unbonded concrete overlay of concrete pavements
- Unbonded concrete overlay of asphalt pavements
- Unbonded concrete overlay of composite pavements

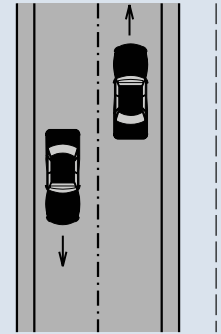

STAGE 1.

Repair surface, prepare for overlay, and construct left shoulder

- In order to construct an overlay on a roadway with a minimum of 2 ft (0.6 m) wide existing shoulders, adjustments to typical slipform pavers are necessary in order to meet existing clearances adjacent to the paver. The width of the clearance zone is dependent on traffic control, paver track, and paver control (stringline). When there is not enough clearance for the paver track, paving molds may be installed on typical two-track pavers to provide zero clearances. The outside edges of the mold are brought out behind the rear tracks and then the material from the front of the paver is moved to the back by an auger to be spread and paved.
- Install traffic control and close the left lane. Follow jurisdictional requirements for traffic control. Check

with jurisdiction regarding allowable lane closure length. If surface repair and preparation for the overlay are minimal, then slow-moving traffic control may be appropriate. Closing the lane may require additional traffic control (e.g., signals, flaggers, and/or pilot cars).

- Repair the surface as appropriate. Prepare the surface for the overlay (or, in the case of concrete overlay on concrete, the separation layer) as described in the contract document.
- Construct calcium chloride treated granular shoulder as outlined in contract documents. The treated shoulder shall be firm and stable to support vehicular traffic at low speeds.
- Construct separation layer (only for unbonded overlay on concrete).

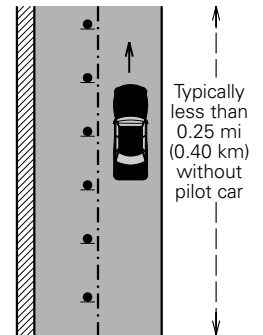

STAGE 2.

Construct right shoulder and concrete overlay

- Shift the traffic control to the left lane and close the right lane to traffic. The length of the closure will depend on the jurisdiction's maximum closure length with pilot car. Traffic controls and traffic control signals will be based on jurisdictional requirements.
- Repair and prepare the surface for the overlay or the separation layer and subsequent overlay as described in the contract documents. Construct separation layer (for unbonded overlay).
- Normal space for the paver stringline is 1–1.5 ft (0.3–0.5 m) and the paver track is a minimum of 2.5–3 ft (0.8–0.9 m). 1 ft (0.3 m) incremental encroachment reduction (up to 2 ft [0.6 m] total) is common through typical machine adjustment. Modification to a conventional paver is

necessary to achieve these dimensions. Speeds should be restricted adjacent to paver when clearance between the paver and vehicle traffic is limited.

- Construct concrete overlay on the existing pavement. Bull float work shall operate from the outside shoulder only.
- Place 6 in. (150 mm) minimum thickness calcium chloride treated granular shoulder to help stabilize shoulder and minimize heavy dust that can impair vision.
- The 1.5 ft (0.5 m) dimension between the roadway centerline and vertical panel is for the stringline and fillet.

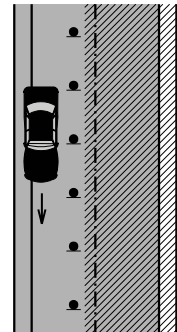

STAGE 3.

Construct left lane concrete overlay

- Close the opposite lane to traffic and place the concrete overlay according to contract documents, using the same procedures as described in stage 2.
- Complete shouldering. Complete pavement marking and regulatory signing in accordance with contract documents.

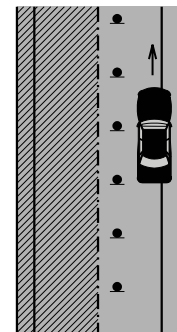
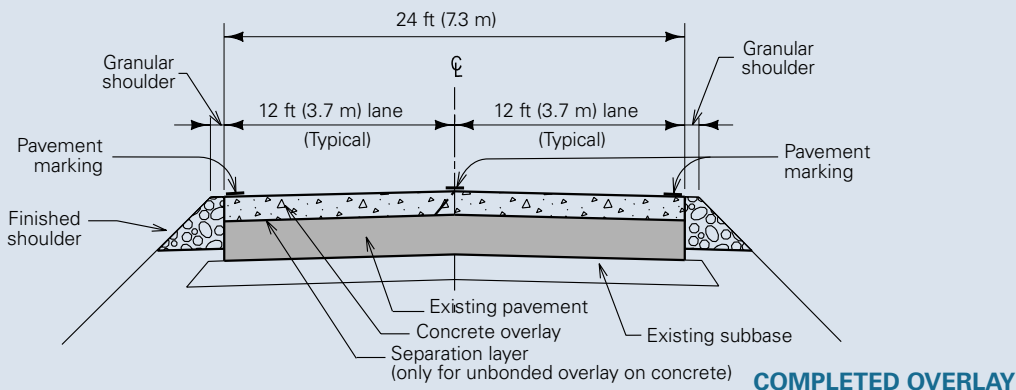





Figure 106. Overlay of two-lane roadway with minimum granular shoulders (zero-clearance paver)



LEGEND

-  Stage work area
-  Concrete
-  Granular material

NOTES:

- ① Follow jurisdictional requirements for traffic control devices. Outside shoulder traffic control may depend on width of shoulder.
- ② Existing shoulder should have minimum 6 in. (150 mm) of granular material and should be treated with calcium chloride.
- ③ Minimum lane width next to the paver may be reduced for short-term, stationary work on low-volume, low-speed roadways when vehicular traffic does not include longer and wider heavy commercial vehicles.
- ④ Place granular shoulder with calcium chloride in two lifts. The first lift is for the paver track. The second lift is for final shoulder. If the completed overlay in this stage opens to traffic and the final lift is delayed, place concrete fillet as shown. If overlay creates a dropoff greater than jurisdictional allowance, place second lift before opening overlay to traffic.
- ⑤ See centerline fillet illustration and subsequent removal on figure 103.
- ⑥ Requires minimum to zero clearance paver. 1.5 ft (0.5 m) dimension is for the paver ski or stringline.
- ⑦ Mark edgelines and centerlines per MUTCD (FHWA 2009) section 6F.77 (mark both lanes).
- ⑧ For low-volume roads only

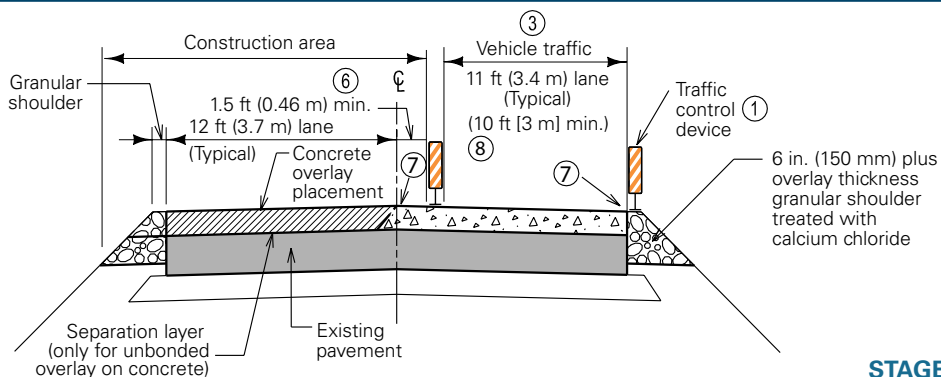
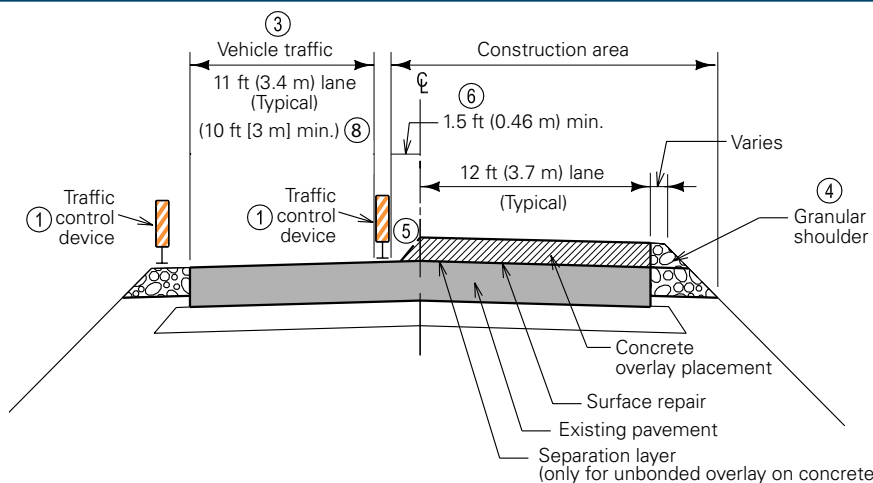
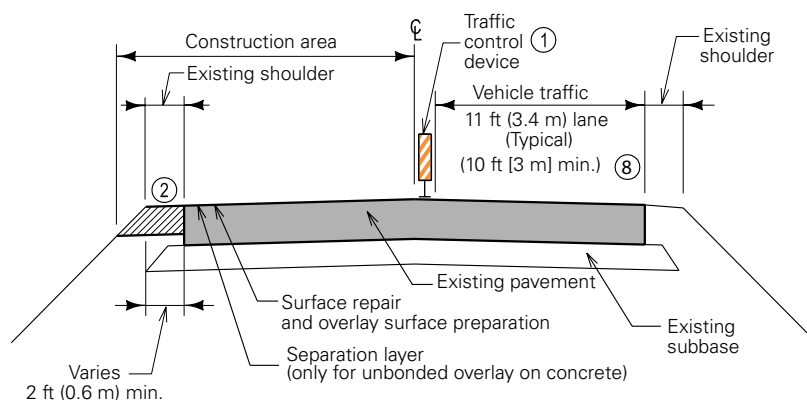

Overlay of Two-Lane Roadway with Minimum Granular Shoulders (Zero-Clearance Paver)

COMPLETED OVERLAY (Two-Lane Roadway Widened to Three Lanes with Paved Shoulders, Conventional Paver)

Applied to:

- Bonded concrete overlay of concrete pavements
- Bonded concrete overlay of asphalt pavements
- Bonded concrete overlay of composite pavements
- Unbonded concrete overlay of concrete pavements
- Unbonded concrete overlay of asphalt pavements
- Unbonded concrete overlay of composite pavements

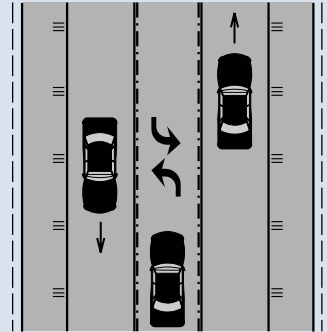

STAGE 1.

Repair surface, prepare for overlay, and construct base shoulder widening and separation layer

- Install traffic control and close the left lane. Follow jurisdictional requirements for traffic control. Check with jurisdiction regarding allowable lane closure length. If surface repair and preparation for the overlay are minimal, then slow-moving traffic control may be appropriate. Closing the lane may require additional traffic control (e.g., signals, flaggers, and/or pilot cars).
- Repair the surface as appropriate. Prepare the surface for the overlay (or, in the case of concrete overlay on concrete, the separation layer) as described in the contract document.
- Prepare shoulder widening by trenching the existing shoulder and trimming to the specified width. The trench should be rolled and compacted as necessary to obtain a firm and stable platform. Compact shoulder material as specified in the contract documents. A continuous progression approach with the shoulder trencher and placement of the base shoulder widening is encouraged.
- Pave the existing shoulder a minimum of 6 ft (1.8 m) with concrete.
- Use excavated granular material to widen existing shoulder. Treat 3 ft (0.9 m) area of shoulder with calcium chloride.
- Construct separation layer (only for unbonded overlay on concrete).

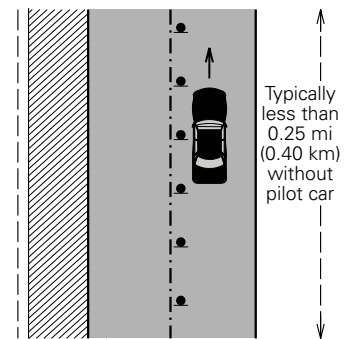

STAGE 2.

Construct thickened shoulder and concrete overlay

- Shift the traffic control to the left lane and close the right lane to traffic. The length of the closure will depend on the jurisdiction's maximum closure length with pilot car. Traffic controls and traffic control signals will be based on jurisdictional requirements.
- Repair and prepare the surface for the overlay or the separation layer and subsequent overlay as described in the contract documents. Construct separation layer (for unbonded overlay).
- Construct concrete overlay on the existing pavement. Complete right PCC shoulder widening with the overlay.
- The "X" dimension between the roadway centerline and vertical panel is for the paving machine track and stringline.

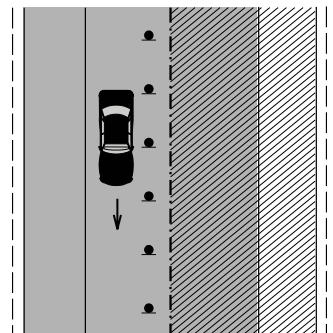

STAGE 3.

Construct left lane concrete overlay

- Close the opposite lane to traffic and place the concrete overlay according to contract documents, using the same procedures as described in stage 2. Stringline may not be necessary for the right edge of the paving when the paved overlay constructed in stage 2 is used as the paver control in this stage.
- If the outside edge dropoffs at the shoulder exceeds the jurisdictional allowance for a 1:1 fillet, then construct the granular shoulders in this stage.
- Complete shoulders. Install (mill) rumble strips in the paved shoulders and complete pavement marking and regulatory signing in accordance with contract documents.

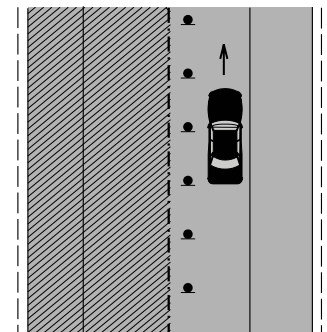



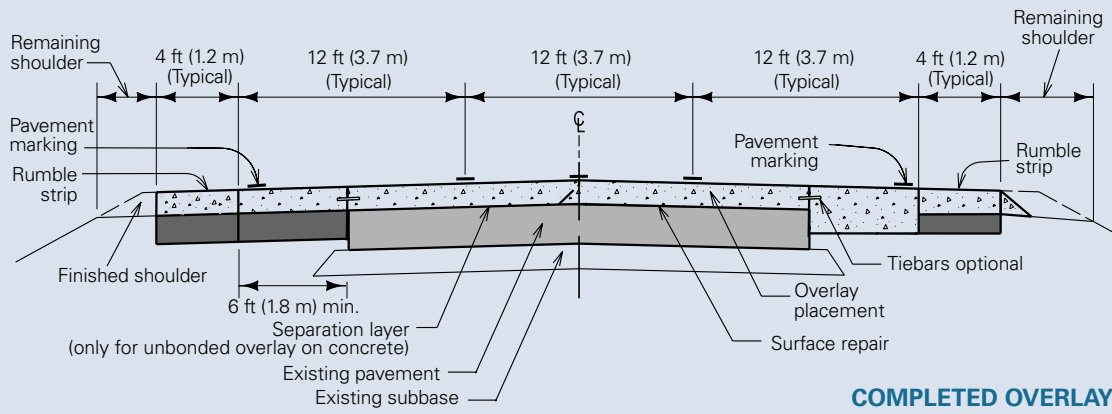

Figure 107. Overlay of two-lane roadway widening to three lanes with paved shoulder (conventional paver)

LEGEND

-  Stage work area
-  Concrete
-  Base shoulder widening materials (e.g., cement-treated base, porous concrete, roller compacted concrete (RCC), asphalt, or concrete)
-  Granular material



COMPLETED OVERLAY

NOTES:

- ① Follow jurisdictional requirements for traffic control devices.
- ② Use excavated granular material to widen existing shoulder. Treat 3 ft (0.9 m) area of shoulder with calcium chloride.
- ③ Minimum lane width next to the paver may be reduced for short-term, stationary work on low-volume, low-speed roadways when vehicular traffic does not include longer and wider heavy commercial vehicles.
- ④ If the completed overlay in this stage opens to traffic and the final shoulder back fill is delayed, place fillet as shown. If overlay creates a dropoff greater than jurisdictional allowance, place second lift before opening overlay to traffic.
- ⑤ See centerline fillet illustration and subsequent removal on figure 103.
- ⑥ Mark edgelines and centerlines per MUTCD (FHWA 2009) section 6F.77 (mark both lanes).

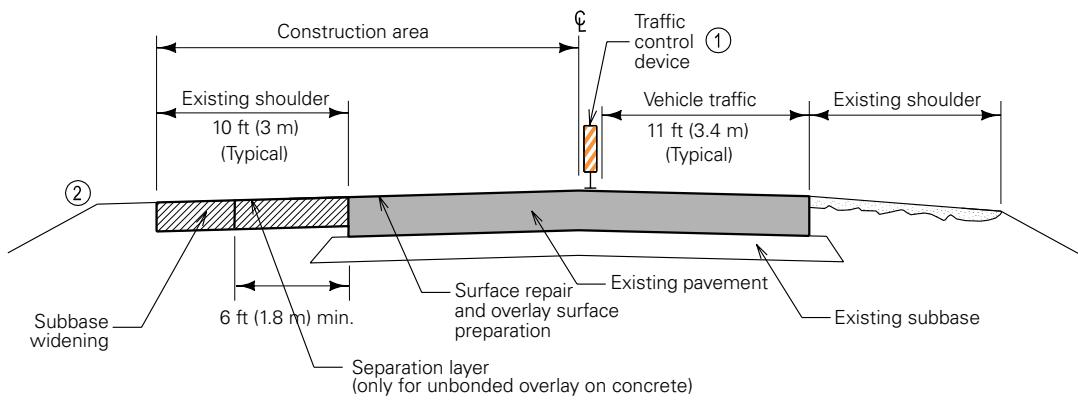

STAGE 1

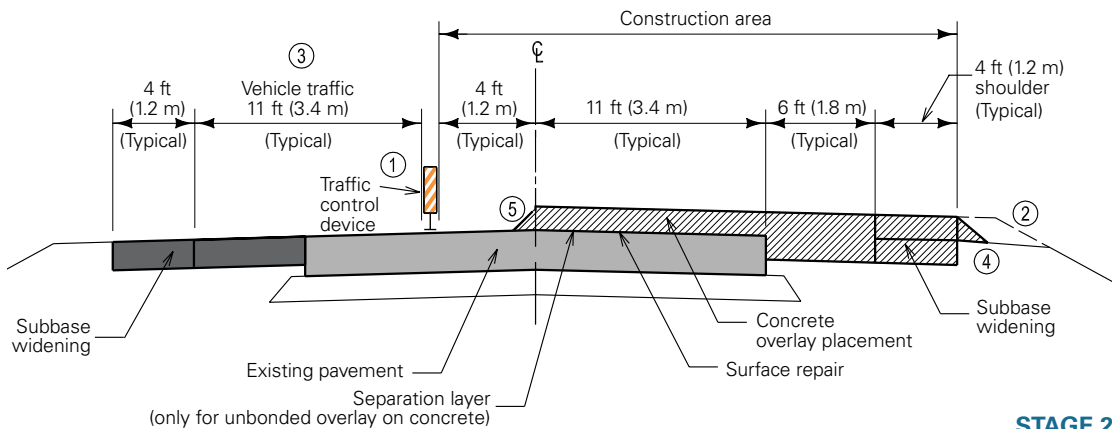

STAGE 2

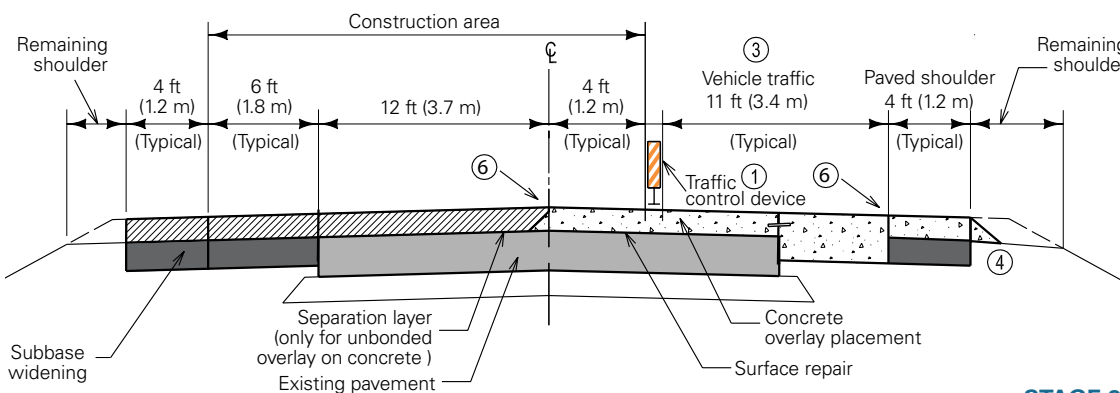

STAGE 3

Overlay of Two-Lane Roadway Widened to Three Lanes with Paved Shoulders (Conventional Paver)

COMPLETED OVERLAY (Four-Lane Roadway with Paved Shoulders, Conventional Paver)

Applied to:

- Bonded concrete overlay of concrete pavements
- Unbonded concrete overlay of concrete pavements
- Bonded concrete overlay of asphalt pavements
- Unbonded concrete overlay of asphalt pavements
- Bonded concrete overlay of composite pavements
- Unbonded concrete overlay of composite pavements

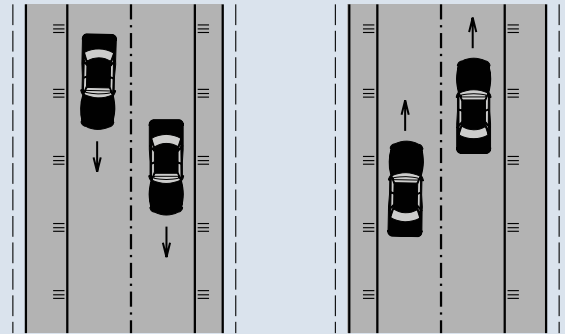

STAGE 1. Repair surface and prepare for overlay

- Install traffic control and close the inside lanes. Follow jurisdictional requirements for traffic control. Check with jurisdiction regarding allowable lane closure length. If surface repair and preparation for the overlay are minimal, then slow-moving traffic control may be appropriate. Closing the lanes may require additional traffic control (e.g., signals and flaggers).

- Repair the surface as appropriate. Prepare the surface for the overlay (or, in the case of concrete overlay on concrete, the separation layer) as described in the contract document.
- Evaluate the structural condition of the existing shoulder. Mill existing shoulder or reconstruct shoulder to carry traffic load if necessary.
- Construct separation layer (only for unbonded overlay on concrete).

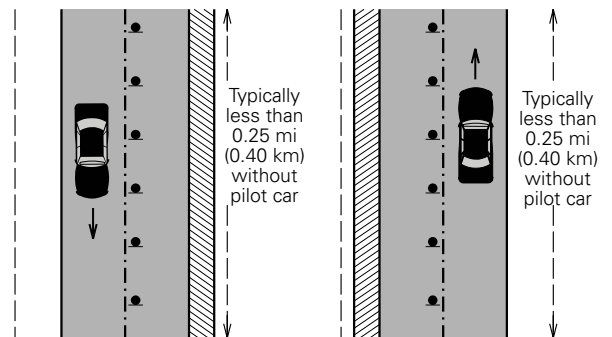

STAGE 2. Construct concrete overlay on outside lane

- Shift the traffic control to the inside lanes and close the outside lanes to traffic. Traffic controls and traffic control signals will be based on jurisdictional requirements.
- Repair and prepare the surface for the overlay or the separation layer and subsequent overlay as described in the contract documents. Construct separation layer (for unbonded overlay).

- Construct temporary shoulder for paver track.
- Construct concrete overlay on the existing pavement. Bull float work shall operate from the outside shoulder only.

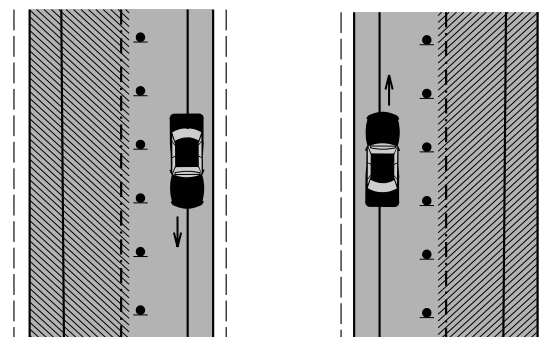

STAGE 3. Construct concrete overlay on inside lane

- Shift the traffic control to the outside lane and close the inside lane to traffic. Place the concrete overlay according to contract documents, using the same procedures as described in stage 2. Stringline may not be necessary for the right edge of the paving when the paved overlay constructed in stage 2 is used as the paver control in this stage.

If the right stringline is not used, the "X" dimension could possibly be reduced to 3 ft (0.9 m).

- Complete shoulder finish grading. Install (mill) rumble strips in the paved shoulders and complete pavement marking and regulatory signing in accordance with contract documents.

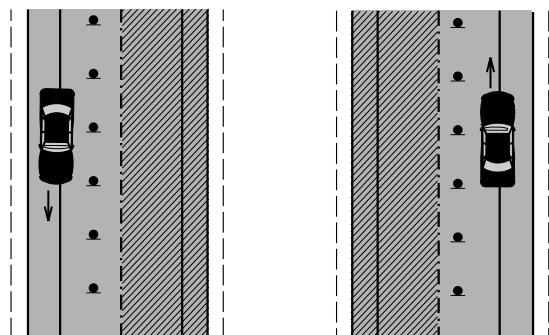





Figure 108. Overlay of four-lane roadway with paved shoulders (conventional paver)

LEGEND

-  Stage work area
-  Concrete
-  Existing shoulder (Reconstructed if necessary)

NOTES:

- ① Follow jurisdictional requirements for traffic control devices.
- ② Evaluate the structural condition of the existing shoulder. If necessary, reconstruct shoulder with PCC or asphalt to carry the traffic load.
- ③ See centerline fillet and subsequent removal illustration on figure 103.
- ④ When the existing shoulder outside of the proposed paved shoulder is less than 3 ft (0.9 m), adjustment to the paver may be necessary to accommodate paver control and paver track.
- ⑤ If the completed overlay in this stage opens to traffic and the final shoulder backfill is delayed, place fillet as shown. If overlay creates a dropoff greater than jurisdictional allowance, place second lift before opening overlay to traffic.
- ⑥ For "X" less than 4 ft (1.2 m), adjustments to paver may be necessary to accommodate paver control and paver track.
- ⑦ The "X" dimension can be reduced to 3 ft (0.9 m) minimum when the right lane is used as paver control.
- ⑧ Mark edgelines and centerlines per MUTCD (FHWA 2009) section 6F.77 (mark both lanes).

Overlay of Four-Lane Roadway with Paved Shoulders (Conventional Paver)

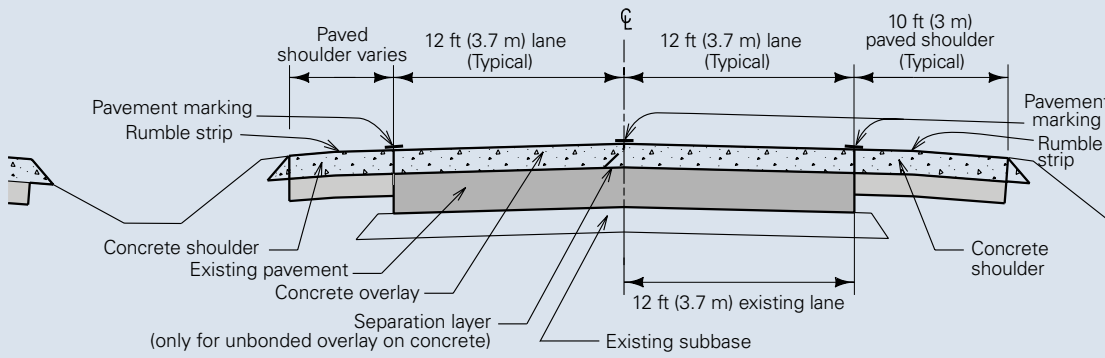

COMPLETED OVERLAY

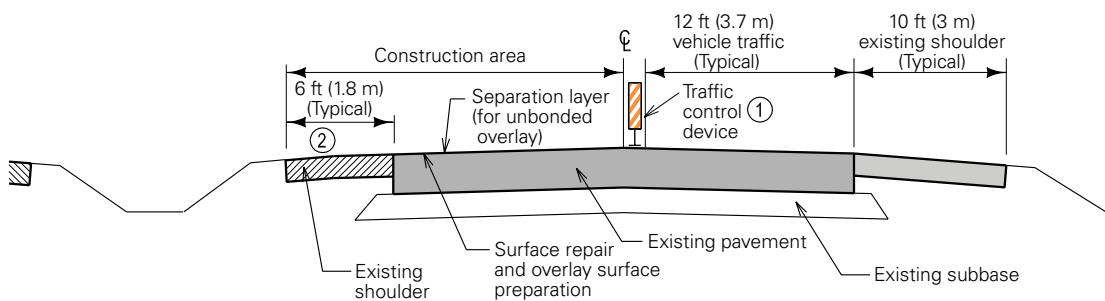

STAGE 1

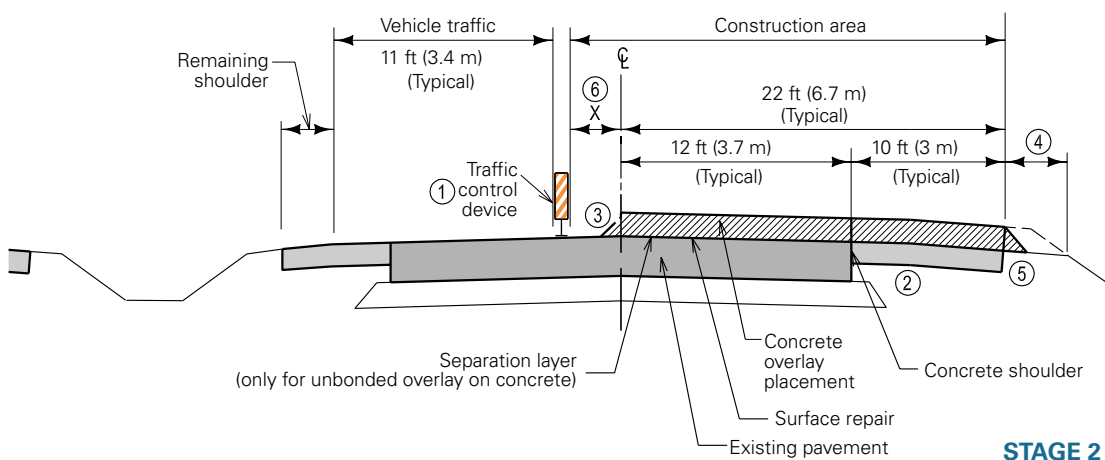

STAGE 2

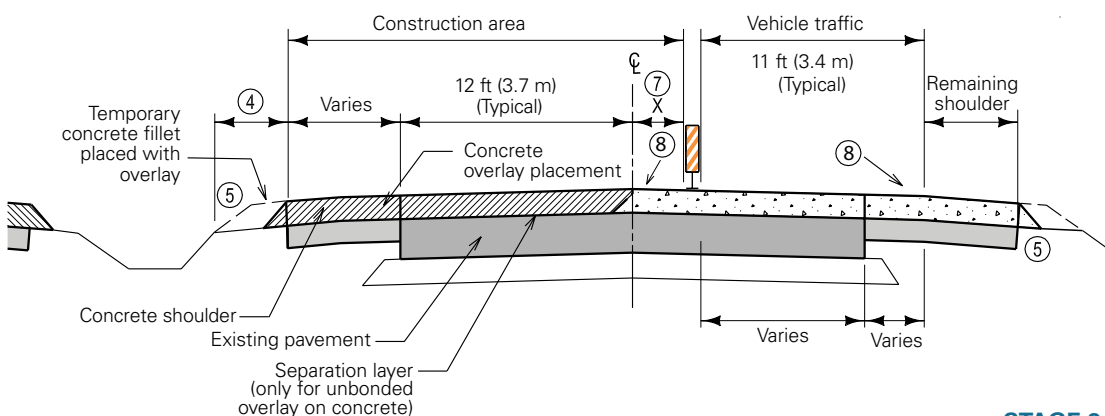

STAGE 3

Chapter 7.

CONSTRUCTION OF CONCRETE OVERLAYS

Concrete overlays are constructed using conventional equipment and procedures. See Appendix G for information about developing project and supplemental specifications and Appendix H for suggestions regarding owner-contractor meetings.

Total construction time for concrete overlays is significantly shorter than reconstruction of a roadway because earthwork is limited to minor quantities. Resurfaced streets and highways can be opened to traffic within short periods of time with adequate planning, expedited staging, and efficient operations.

Key Points for Concrete Overlay Construction

Normal concrete paving construction practices can be used to complete concrete overlay projects as quickly and efficiently as any other paving method. Resurfaced streets and highways can be opened to traffic within a short period of time with adequate planning, expedited staging, and efficient operations. See Table 21.

FAQ – Is there anything different about constructing a concrete overlay?

Typically, no; the same methods and equipment are used as in new concrete pavement construction. There are, however, some considerations for placement during cooler periods (spring and autumn). Under these conditions, the existing base and pavement will expand and contract with the daily change in ambient temperature. Cracking may occur if the concrete mixture has not gained enough strength to withstand the stresses caused by differential movement between the underlying pavement structure and the new concrete overlay. Accelerating the rate of strength gain in the concrete mixture is the recommended way to mitigate the effects of differential movement due to changes in ambient temperature. There are a number of methods that can be used to accomplish this; they may be used alone or, in many cases, in combination:

- Heat the concrete to maintain a fresh concrete temperature of at least 75°F.
- Use a nonchloride accelerating admixture.
- Cover the new overlay pavement with insulating blankets, burlap, and/or polyethylene sheeting.
- When possible, reduce the quantity of supplementary cementitious materials in the mixture.

HIPERPAV is a software tool available to predict stresses in concrete. It is especially useful when there is a need for more information in less-than-desirable conditions, such as inclement weather conditions, when an overlay is particularly thin, or when a project does not have much flexibility in scheduling.

Payment is typically based on two items: square yards and cubic yards. The surface is measured to account for the square-yard surface area, and batch tickets are collected to account for the cubic-yard concrete volume, including variable depths.

Table 21. Concrete Paving Construction Practices for Overlays

Construction Consideration	Bonded Overlays		Unbonded Overlays	
	Bonded Overlays of Concrete	Bonded Overlays of Asphalt or Composite	Unbonded Overlays of Concrete	Unbonded Overlays of Asphalt or Composite
1. Mixture Design				
Aggregate:				
Physically and chemically stable and durable	X	X	X	X
Well-graded mix	X	X	X	X
Match aggregate thermal properties with existing pavement	X			
Maximum aggregate size should be D/2.5 in relation to the new overlay thickness	X	X	X	X
Use conventional mixtures with Type I or II cement.	X	X	X	X
Use fly ash and slag to reduce permeability with w/cm ratio not to exceed 0.42.	X	X	X	X
Use water reducer to help maintain w/cm ratio and desired slump, as well as to increase strength.	X	X	X	X
If accelerated construction is desired, accomplish this through careful scheduling and diligent execution; accelerated concrete mixtures should only be used in limited areas where early opening cannot be achieved through other means.	X	X	X	X
Fibers may be used to increase the “toughness” of concrete (measure of its energy-absorbing capacity), improve resistance to deformation, hold concrete together in case of cracking, and serve as an insurance policy that protects the surface from unseen base conditions.	X	X		
Verification testing in the laboratory of nonstandard mixes (trial batches) and specifications of testing at temperatures representative of site conditions is encouraged to flag any mix problems.	X	X	X	X

Table 21. Concrete Paving Construction Practices for Overlays, continued

Construction Consideration	Bonded Overlays		Unbonded Overlays	
	Bonded Overlays of Concrete	Bonded Overlays of Asphalt or Composite	Unbonded Overlays of Concrete	Unbonded Overlays of Asphalt or Composite
2. Grade Control				
Centerline profile only (as-built) with uniform finished cross section	X	Mill and concrete overlay		
Three-line profile (edges and centerline) when cross slope varies or surface distortions exist	X	Little or no milling	Inlays only	Inlays only
Measure off existing pavement or top of milled surface to set stringline or form. Adjust individual points up to produce a smooth line.	X	X	X	X
Survey 100–500 ft (30.5–152 m) cross sections when shouldering, foreslopes, and backslopes need adjusting. If the existing profile grade is irregular, additional centerline elevations may be necessary for grade corrections in certain locations for smoothness.			X	X
Survey bridge tie-ins or bridge clearance conditions and extreme superelevations.	X	X	X	X
To prevent thicker asphalt separation layer and thus compaction, stability, and grade control issues, use concrete to make up any 3 in. (75 mm) or greater variances in grade and a nominal 1 in. (25 mm) asphalt separation layer.			X	
3. Preoverlay Repairs for Uniform Support				
Minimal minor repairs of surface defects. Remove deteriorated area and replace with overlay.	X			
An engineer should observe final condition of subbase pavement prior to overlay construction. For minimal isolated distress that causes some loss of structural integrity that cannot be overcome with milling, thicken the overlay in this area.		X		
Replace isolated areas of subbase pavement when there is evidence of active movement.			X	X
Joint deterioration with little or no faulting can be bridged with the overlay.			X	
To widen the roadway, excavate the shoulder to allow for the widened thicker section to be placed with the overlay.	X	X	X	X
Fill cracks in the HMA with sand or flowable mortar when the crack width exceeds the maximum coarse aggregate size used in the concrete overlay mixture.		X		X
4. Surface Preparation				
Surface roughness for bonding:				
Shotblasting (even after milling)	X			
Milling to remove significant distortions or reduce high spots		X		X
Surface cleaning:				
Sweeping followed by high-pressure airblasting (waterblasting may be needed to remove dirt tracked onto surface)	X	X		
Surface sweeping only			X	X
Maintain a clean and dry surface.	X	X		
Sprinkle (mist) the existing pavement when the surface temperature exceeds 120°F; use compressed air to remove any standing water directly ahead of the concrete-placing operation	X	X	X	X
Place nominal 1 in. (25 mm) asphalt layer to separate concrete layers and prevent bonding. When heavy truck traffic is anticipated, it is advisable to consider a drainable asphalt layer and drainage system.			X	
If the existing asphalt surface of a composite pavement section remains intact, it can serve as a separation layer.				X
5. Concrete Placement				
When the surface temperature of the asphalt is at or above 120°F (49°C), surface watering can be used to reduce the temperature and minimize the potential for shrinkage cracking. No standing water should remain at the time the overlay is placed.		X	X	X
The bonding of the overlay can be affected by the climatic conditions at the time of placement. Significant stresses that develop due to rapid changes in temperature, humidity, and wind speed may reduce the bond strength under severe conditions. HIPERPAV can predict interface bond stress based on numerous factors.	X	X		
Feeding concrete consistently into the paver requires an adequate number of batch delivery trucks. The number of trucks will often dictate the slipform or placement speed. The entire cycle of mixing, discharging, traveling, and depositing concrete must be coordinated for the mixing plan capacity, hauling distance, and spreader and paving machine capabilities. Extra trucks may be needed as the haul time increases.	X	X	X	X
Do not track paste or dirt onto the existing surface ahead of the paver because it can cause bond failure.	X	X		

Table 21. Concrete Paving Construction Practices for Overlays, continued

Construction Consideration	Bonded Overlays		Unbonded Overlays	
	Bonded Overlays of Concrete	Bonded Overlays of Asphalt or Composite	Unbonded Overlays of Concrete	Unbonded Overlays of Asphalt or Composite
The manner in which the crew deposits concrete in front of the paving operation is an important factor for creating a smooth pavement surface in overlay projects. Placement in front of slipform paver should be done in small overlapping piles so as to minimize lateral movements.	X	X	X	X
Properly established, secure, and maintained stringline is very important for smoothness; constant and continuous paving prevents interruptions that lead to bumps.	X	X	X	X
Tiebars may be appropriate in an open-ditch situation when constructing 3- to 6-ft (0.9- to 1.8-m) widening units and overlay thickness is 5 in. (125 mm) or greater. Normally, tiebars are not used for lane widening to prevent cracking from stresses due to differential expansion and contraction between lanes.	X	X		
Dowel bar use should follow full-depth pavement requirements. Pavements less than 7 inches thick should not use load transfer dowels. When used for thicker pavements, they should be located approximately in the mid-third of the overlay thickness. Isolated thicker sections should not dictate a change in basket height or dowel bar insertion depth.		X	X	X
Texturing needs to be performed at the right time so as not to disturb setting of the concrete. Shallow longitudinal tining or burlap/turf are two effective textures. Burlap/turf drag has shown adequate friction with a quiet surface when hard sands are used in the mix.	X	X	X	X
6. Curing to Prevent Rapid Loss of Water from Concrete				
Proper curing of bonded and thin unbonded overlays is particularly important because they are thin with a large surface compared with the volume of concrete. The curing rate may be increased from the normal rate to provide additional protection. Standard curing compound rates may be used for thicker unbonded overlays.	2 times normal	1.5–2 times normal	1.5–2 times normal	1.5–2 times normal
During hot weather, steps should be taken to reduce the evaporation rate from the concrete. For significant evaporation, provide a more effective curing application, such as fog spraying, or apply an approved evaporation retarder.	X	X	X	X
Adequate curing of overlays on a stiff support system (especially on underlying concrete pavement) is important to minimize curling and warping stresses.	X	X	X	X
7. Joints				
Joint spacing for concrete overlays requires special consideration for each type:				
Joints are to be matched with underlying concrete to prevent reflective cracking.	X			
When feasible, it is a good policy to mismatch joints and/or cracks to maximize load transfer from the underlying pavement. Some states that have not intentionally mismatched joints, however, have not experienced any adverse effects.			X	X
Slab dimensions match the underlying pavement.	X			
The recommended joint pattern for bonded overlays of asphalt should not exceed 1.5 times the overlay thickness in inches.		X		
For overlays less than or equal to 6 inches thick, the slab dimensions (in feet) should not exceed 1.5 times the overlay thickness in inches (e.g., 4 in. x 1.5 ft/in. = 6 ft).			X	X
For overlays greater than 6 inches, the slab dimensions (in feet) should not exceed 2.0 times the overlay thickness in inches, not to exceed 15 ft.			X	X
Because of the potential for higher curling and warping stress from a rigid underlying pavement, shorter than normal spacing is typical (see pages 40, 44, and 48).			X	X
Joint sawing:				
The timing of sawing is critical. Sawing joints too early can cause excess raveling. HIPERPAV may be useful in helping to predict the appropriate time window for joint sawing, based on the concrete mix design, construction times, and environmental conditions.	X	X	X	X
Sawing must be completed before stresses exceed the strength developed. Sawing too late can lead to uncontrolled cracking.	X	X	X	X
Transverse joint saw-cut depth for conventional saws	Full depth + 0.50 in. (13 mm)	T/3	T/4 min.-T/3 max.	
Transverse joint saw-cut depth for early-entry saws	Full depth + 0.50 in. (13 mm)	Not < 1.25 in. (32 mm)	Not < 1.25 in. (32 mm)	
Longitudinal joint saw-cut depth	T/2 (at least)	T/4 – T/3	T/4 – T/3	
Transverse joint width must be equal to or greater than the underlying crack width at the bottom of the existing transverse joint.	X			
Sealing:				
Seal joint using low-modulus hot-pour sealant with narrow joint.	X	*	**	**

* Joint between overlay and curb and gutter should be sealed.

** Some states have experienced problems with asphalt stripping of the separation layer, particularly under heavy truck traffic and high speeds. Therefore, sealing is important in these conditions. On lower speed roads without a heavy traffic loading, some states successfully do not seal.

Bonded Overlays: Ensuring Proper Bond

When bonding a concrete overlay to an existing concrete surface, the necessity for a sound bond cannot be overstated. Both theory and practice show that without this bond, the overlay will develop secondary distress quickly, thus significantly compromising the life of the pavement system. Research has attempted to measure and characterize bond strength during early ages of the concrete overlay. To date, however, no simple and reliable test has been developed. As a result, bond strength is typically characterized using a surrogate test, namely strength (compressive or flexural) of the overlay. The strength of the bond between the overlay and the existing concrete pavement can be correlated with the flexural/compressive strength of the overlay. If the recommended construction procedures have been performed correctly, and the early opening strength criteria have been met, then the bond strength should also be adequate to allow the pavement to be open without bond failure, provided that care has been taken to prepare the existing pavement surface properly and the overlay has been adequately cured.

Several elements (beyond those common to a typical concrete pavement) are particularly important in ensuring a good bond between the concrete overlay and the underlying concrete pavement. There are issues related to the concrete mixture, joint spacing, surface preparation and cleaning, curing, sawing, and strength measurement. While several of these factors are currently considered in conventional concrete paving, specific emphasis should be placed on certain key factors of these elements, since bonded concrete overlays are particularly sensitive to volumetric changes.

Concrete mixtures used in bonded concrete overlays should shrink as little as possible and have similar thermal properties, or CTE (see page 52 for more information). This typically means optimizing the cement content to minimize shrinkage while maintaining an adequate strength. Another mixture-related consideration is aggregate gradation (which helps in reducing cement factors without sacrificing strength), as well as aggregate type. To help minimize the thermal strains and stresses experienced at the bond line of bonded overlays over concrete, the overlay should have aggregate thermal properties similar to the aggregate in the underlying concrete pavement. If local aggregate sources make matching the thermal coefficient difficult, an effort should be made to use only aggregates

FAQ—If the mean texture depth of the existing pavement is in the recommended range or higher, do I have to shotblast or mill the pavement?

Yes; although the mean texture depth is a consideration, the shotblasting or milling is necessary to remove laitance buildup from rubber, grease, and oil over many years of use.

with a thermal coefficient lower than that of the aggregates in the existing pavement.

Surface preparation of the existing concrete pavement is accomplished to produce a roughened surface that will promote bonding between the two layers; see Figure 109. A variety of surface preparation procedures may be used, including shotblasting and milling. A bonding grout or epoxy is not required. The most commonly used and most effective surface preparation procedure is shotblasting. Although milling will roughen the concrete pavement surface, milling should not be used solely for that purpose because of its potential for causing surface microcracking and fracturing the exposed aggregate. If milling is used to lower the pavement elevation, any resulting microcracking should be removed by shotblasting.

In some cases, a surface roughness or mean texture depth is specified. The sand patch test (ASTM C 965) is often used to measure and verify the mean texture depth. Typically, a mean texture depth in the range of 0.04–0.08 in. (0.9–2.0 mm) is deemed adequate for proper bond development.

Following surface preparation, the surface should be thoroughly cleaned to remove all

loose material to ensure adequate bonding. Cleaning may be accomplished by sweeping the concrete surface, followed by cleaning in front of the paver with compressed air. Airblasting and waterblasting should be used only as supplementary cleaning procedures to remove loose material from the surface after shotblasting or milling. No visible moisture should remain on the pavement surface when the overlay is placed. Paving should commence soon after cleaning to minimize the chance of contamination.

Vehicles should be limited on the existing surface after it is prepared. If it is absolutely necessary to have vehicles on the existing concrete, care should be taken that they do not drip oil or other contaminants that could compromise the bond. When the surface temperature of the concrete is at or above 120°F (49°C), water misting can be used to reduce the temperature and minimize the chance of shrinkage cracking. Water standing on the surface should be blown off with compressed air.

Curing also can have a pronounced impact on concrete overlay bond. The diligent and thorough application of a curing compound (sometimes at twice the normal application rate) is an effective method to control



Figure 109. Compare the surface texture of the nonshotblasted area (upper left half of image) to the roughened surface texture on the shotblasted section of pavement (under the pen) (source: Leif Wathne, ACPA)

moisture loss and thus lower shrinkage and early-age cracking potentials. This is particularly true for thin bonded overlays. More “extreme” measures, such as wet or blanket curing, can help to minimize the risks of poor performance when proper curing compound application is either difficult or doubtful. These types of more “extreme” curing regimes are typically only applicable for short paving sections such as intersection rehabilitation.

Good construction sawing practices can also greatly reduce early pavement stresses and help accommodate early opening to traffic. As mentioned elsewhere in this document, sawing the transverse joints in the new overlay full depth plus 0.5 inch, exactly over the joints in the existing pavement, is absolutely critical for proper bonding. There have been examples of early bonded concrete overlay failures due to debonding as a result of not sawing the joints completely through the depth of the overlay or failing to match the location of the underlying joint. The width of the initial saw cut in the overlay should be equal to or greater than the width of the cracks under transverse joints in the existing pavement; see Figure 48 on page 58.

When all of these factors have been properly considered and executed during construction, the overlay strength can be used to characterize the bond with some confidence. Strength monitoring of the overlay concrete can be done in a fashion similar to that of conventional concrete paving. Maturity methods for early-age strength prediction (ASTM C 1074) can be particularly helpful. If all recommended construction procedures are followed, and knowing that bond strength correlates reasonably well with concrete strength, early opening decisions can be made relatively reliably, in-place, and in a timely fashion.

Unbonded Overlays: Installation of Geotextile Interlayer Fabric

If an unbonded overlay is being constructed, an asphalt or geotextile fabric separation layer must be placed before the overlay is placed. Geotextile separation layers require some special installation practices.

Before placing the geotextile, the surface of the existing pavement should be swept clean of loose material with either a mechanical sweeper or an air blower. Then conventional placement practices and procedures should be followed for placing the separation layer.

Both pervious (geotextile fabric or open-graded asphalt) and impervious (densely graded HMA) types of separation layers must drain at the pavement edges or risk trapping water, which can be very damaging. The layer can either be daylighted at the edges (allowing the egress of water) or terminate in a subdrain or other layer (allowing the water to flow away from the pavement structure).

In general, the following construction practices have resulted in successful installations of geotextile separation layers:

- Place the material as shortly before paving as possible (ideally no longer than 2 to 3 days) to reduce the potential for it to be damaged.
- Before placing the nonwoven geotextile material, these actions should be taken:
 - Repair the existing pavement to correct any significant cracking.
 - When faulting greater than 0.25 inch (or as specified by the engineer) is present, it may be reduced by milling.
 - Sweep the pavement surface clean.

- Roll the material onto the base or other surface, keeping the nonwoven geotextile tight with no wrinkles or folds.
- Roll out sections of the material in a sequence that will facilitate good overlapping, prevent folding or tearing by construction traffic, and minimize the potential that the material will be disturbed by the paver.
- Overlap sections of the nonwoven geotextile material a minimum of 6 inches and a maximum of 10 inches, and ensure that no more than three layers overlap at any point; see Figure 110.
- Ensure that the edge of the material along drainage areas extends at least 4 inches beyond the pavement edge and terminates above, within, or adjacent to the pavement drainage system.
- Secure the material with pins (nails) punched through 2.0- to 2.75-inch diameter galvanized discs placed 6 feet apart or less, depending on conditions; see Figure 111.



Figure 110. Overlap of nonwoven geotextile material section



Figure 111. Fastening nonwoven geotextile fabric to existing concrete pavement

- A limited number of projects have used an adhesive for securing the geotextile to the existing pavement; for more information, see 3M (2013).
- Construction traffic on the geotextile should be limited to only that necessary to facilitate concrete paving; see Figures 112 and 113. If construction traffic is placed on the geotextile, precautions should be taken to mitigate tears and wrinkles in the fabric:
 - Leave temporary gaps in the geotextile where trucks are crossing and making sharp turns.
 - Minimize sharp turns and heavy braking, which can cause tearing and wrinkling.
 - Reduce the travel speed of construction traffic.



Figure 112. Paving on top of nonwoven geotextile materials



Figure 113. Paving on top of white geotextile fabric interlayer (source: Larry Engbrecht, South Dakota chapter, ACPA)

Placing Dowel Baskets

If dowel baskets are included in the overlay design, good construction practices should be followed. Anchoring dowel baskets securely to the existing pavement is essential to providing the intended load transfer at contraction joints. Movement of the dowel baskets has been observed on some concrete overlay projects. This movement has been attributed to a number of factors:

- Variable thickness asphalt separation layers require different length nails and different velocity shots as the asphalt thickness changes across the pavement width.
- Newly placed, fine-graded asphalt mixtures provide less friction than a milled surface or existing concrete; reduced friction can cause the dowel baskets to move as the concrete head in front of the paver slides along the surface of the separation layer instead of rolling as the paver moves forward.
- Excessive concrete head in front of the paver can move the dowel baskets.

There are several recommendations for securely anchoring baskets and monitoring their placement:

- Shipping wires should be left intact, unless a MIT SCAN-2 is used for dowel placement verification.
- Use six anchors per basket for existing concrete surfaces.
- Use eight anchors per basket for existing asphalt and composite surfaces.
- Place an equal number of anchors on both sides (paver side and downstream) of the baskets; see Figure 113.
- Place the nails on the downstream side of the basket; see Figure 114.
- Avoid excessive loading from the concrete head in front of the paver.

Dowel placement should be periodically manually verified after the paver has passed over the baskets; see Figure 115. Suspend paving if the baskets are moving during the paving operation until a plan for securely anchoring the baskets is approved. There are numerous

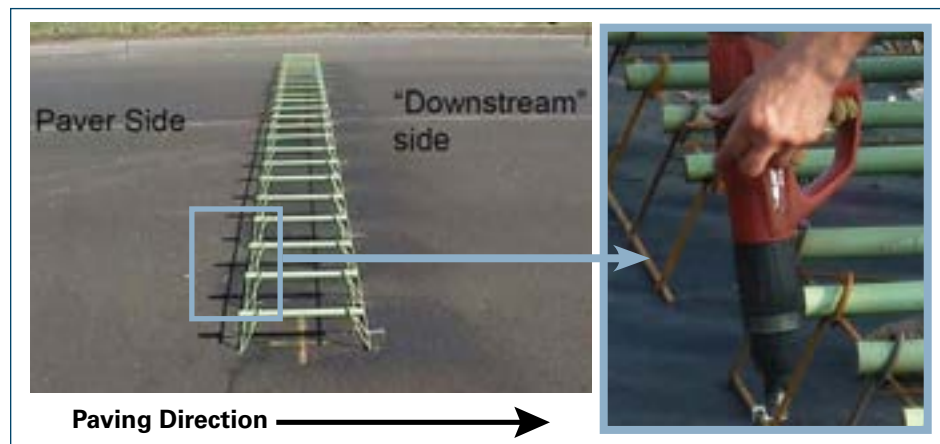

Figure 114. Dowel basket anchor nails should be placed on the downstream side of the basket relative to the direction of pavement



Figure 115. Manually verifying dowel placement

methods available for checking the placement of dowels once the concrete has hardened (MIT SCAN-2, MIT SCAN-T2, ground-penetrating radar, coring, etc.). Although the precision of these methods varies, it is recommended that dowel placement be verified through some means.

Curing Concrete Overlays

While curing is critical (yet often overlooked) for all concrete pavements, it requires particular attention for overlays less than 8 inches thick. The ratio of surface area to volume is greater for thinner overlays than that of typical concrete pavements, thus the same rate of evaporation will have greater detrimental effects on thinner overlays if not properly cured. Excessive drying shrinkage caused by late and/or inadequate curing can lead to reduced bond strengths due to moisture warping within the concrete overlay. There are two primary issues to consider regarding curing of concrete overlays:

1. **Timing**—The curing compound must be applied before any surface evaporation occurs.
2. **Materials**—A good quality curing compound should be used; some state DOTs have had good success with alpha-methyl-styrene curing compounds, but at additional material cost (see page 80 for more information).

Evaporation retardant should be on hand and available for use as emergency protection when the curing operation is delayed. Evaporation retardant should not be used as a finishing aid, but applied when necessary after all finishing operations are completed. A typical coverage rate for thinner overlays (less than 7 inches) is 100 square feet per gallon, applied in two coats. This heavier coverage of curing compound can cause difficulty in sawing on steep hills, especially when lighter early entry saws are utilized, where there is a tendency for the saws to slip on the curing compound. When this is an issue, the second coat of curing compound can be applied after the initial saw cuts have been made.

Differential temperature and moisture values throughout the slab can result in early-age curling and warping stress. When these stresses are added under certain conditions to early-age loading stress, cracking can occur. This can be mitigated through proper curing and sawing techniques. Large variations in ambient temperature and relative humidity at the time of overlay placement can contribute to these stresses. When feasible, the overlay placement should be scheduled around these conditions.

Sawing Joints

Particular attention should be paid to the number of saws required to saw the joints before cracking occurs. Most overlay projects will require both earlier sawing and more saws to accomplish this. Concrete overlay placement rates can easily be limited by the number of saws available; proper planning is necessary to assure that production is not adversely impacted by the capability to effectively saw the joints before cracking can occur. There are a number of factors that contribute to the need for earlier sawing and an increased number of saws:

- Stiffer underlying layers increase internal stresses in the early-age concrete.
- The ratio of lineal feet of joints to square yards of paving is typically higher for concrete overlays; thinner overlays can have significantly more (three to four times) lineal feet of joint per square yard of paving than conventional concrete paving.
- Paving production (square yards per hour) is higher for thinner concrete overlays.
- Thinner overlay sections have a higher ratio of surface area to volume. This can lead to faster strength gain due to solar radiation and also makes the sections more sensitive to drops in ambient temperature, which can increase the risk of random cracking unless the joint sawing operation is timely.

Accelerated Construction

Road improvements not only have direct construction costs, but they also have indirect time-related costs. Construction delays and road closings are generally not well accepted by the road users. One of the significant benefits of accelerated concrete overlay construction is decreasing total construction time, which in turn reduces road user costs and increases driver safety. In addition, concrete overlays offer confidence that the improvements will provide a long-life pavement.

One of the main goals during accelerated overlay construction is to maintain successful traffic management throughout the duration of the project. Acceleration should begin in the design phase with analysis of alternative maintenance of traffic schemes, advance planning, and tailoring of project details to facilitate shortened construction durations. The plans and specifications should provide the contractor with clear criteria for maintenance of traffic requirements (e.g., two lanes open in each direction at all times, pilot car

queues shall not exceed 10 minutes, etc.). Given the requirements for maintenance of traffic, the contractor should be given the responsibility to stage and prosecute the project to meet the objectives for accelerated construction and maintenance of traffic.

Accelerated construction often uses conventional concrete pavement materials and procedures, but key changes can significantly expedite projects; see Appendix I. These changes add flexibility for the contractor. They often involve contract incentives, modifying pavement equipment for minimum to zero clearance, materials proportioning modifications, accelerated curing methods, construction staging, changes to pavement joint construction, and revisions to opening criteria.

Road user costs should be evaluated when determining the type of rehabilitation that is to be implemented. When deciding if accelerated construction is to be implemented, it is important that there is a benefit to be gained such as reducing road user costs and delays. The implementation of accelerated construction techniques on concrete overlays is based on project and user needs. The techniques may be used on critical parts of a project (such as intersections and crossovers), the final segment, or the entire project.

Typically, standard mixtures used in conjunction with accelerated construction techniques are capable of meeting project accelerated opening requirements. In some critical areas, accelerated concrete mixtures are used for concrete overlays. Appendix I outlines a variety of details for planning, designing, and constructing concrete overlays in an accelerated process. Not all items listed are needed for every accelerated overlay project. The following topics, however, should be considered for most projects:

- Staging and maintenance of traffic
- Public relations—coordinating with adjacent businesses and residents to optimize access and constructibility
- Implementing the use of time-related incentives and disincentives to encourage concurrent scheduling and timely completion
- Concrete mixture—using accelerated mixtures only where critical
- Accelerated curing through the use of insulating blankets
- Maturity methods for early opening

Opening Overlay to Traffic

Guidance on concrete strength requirements for opening concrete roadways to traffic is readily available. For example, the *Flexural Strength Criteria for Opening Concrete Roadways to Traffic*, as published by the Transportation Research Board (Cole and Okamoto 1995), bases its opening flexural strengths on thickness, k -values, and estimated ESALs, whereas the FHWA and ACPA's *Traffic Management Handbook* (2000) is based on thickness, foundation support, and the number of ESALs between the time of opening and the time concrete reaches strength. Other methods are available (FHWA 1994) and depend on the type of traffic, early loading locations on the slab, pavement thickness, and subbase support.

Minimizing Early Loading Fatigue Damage

The fatigue life of concrete pavement is sensitive to early wheel loading. A fatigue-consumption approach (Okamoto, et al. 1994) theorizes that concrete pavement has a finite life and can withstand some maximum number of load repetitions, N , of a given traffic loading before fracture. Every individual traffic loading applied decreases the life of the pavement by an amount proportional to the load. This damage value provides the percentage of life that is consumed by the actual number of traffic loads up to a given point in time. It is important to avoid decreases in fatigue life caused by heavy early loadings until the concrete has reached 3,000 psi. Certain techniques can be employed to control early loading that reduces fatigue damage until the concrete strength can accommodate normal traffic loadings.

One of the most important techniques is restricting wheel loads to no closer than 3–4 ft (0.9–1.2 m) from the edge of the pavement (and ideally 6 ft [1.8 m]) to minimize stress. Research has shown that allowing only interior early slab loadings greatly reduces fatigue damage (FHWA 1994). Traffic cones are an effective way of restricting construction traffic along the pavement edges until the pavement reaches the desired full opening strength. In addition to restricting early edge loadings, the use of higher modulus of subgrade reaction, k , can help minimize early-age stress. With concrete unbonded overlays, this is a particular plus, since the underlying pavement provides a high level of base support.

Strength Conversions

The modulus of rupture, or flexural strength, is an important parameter in the estimate

FAQ—When can I open a bonded overlay to traffic so that the loading will not compromise the bond?

The answer is related to minimum concrete strength and not an arbitrarily selected time from placement. Concrete opening strength (compressive or flexural) directly relates to concrete's load-carrying capacity and provides an indication of the bond strength.

of fatigue damage. Many states use flexural strength (modulus of rupture) for concrete opening strength criteria, and others use compressive strength. The following equation is sometimes used to convert compressive strength to third-point flexural strength, although it is widely recognized that this relationship is mixture dependent:

$$MR = (2.3f'_c)^{0.667} \text{ psi}$$

where

$$MR = \text{flexural strength} \\ (\text{modulus of rupture}), \text{ psi}$$

$$f'_c = \text{concrete compressive strength, psi}$$

Note: This empirical equation was developed using data from four different studies, conducted between 1928 and 1965 (Raphael 1984). Also, the equation is contained in reports from ACI Committee 330 (2008).

Since early-age strength can change rapidly in a short time, and since some agencies use a variation of the above referenced equation, it is recommended that each agency develop its own relationship between the compressive strength and flexural strength (modulus of rupture) for the mixture they intend to use. As described earlier, nondestructive tests such as maturity can be used to determine opening strength since it provides real-time results.

Strength Criteria for Opening Bonded Overlay Systems

Strength criteria for bonded overlay systems depend on whether an overlay is placed on concrete or on asphalt.

Bonded on Concrete

If proper surface treatment, curing, and sawing are employed in the construction of concrete overlays, the bond strength at the time of opening should be adequate if 540 psi (3.7 MPa) flexural or 3,600 psi (24.8 MPa) compressive strength is achieved. As a rule of thumb for bonded concrete overlays, the bond tensile strength may be on the order of 2 to 10 percent of the compressive strength, and the bond shear strength approximately 4 to 20 percent of the compressive strength.

Bonded on Asphalt

Bonded concrete overlays on asphalt have one distinct advantage over bonded concrete overlays on concrete. The concrete panels can be cut into small squares or rectangles in order to reduce the curling and warping stresses and the expansion and contraction of concrete at the bond interface because there are no joints that need to be matched in the underlying pavement. The result is a reduction in shear at the bond interface. This technique has been successfully used for a number of years. Overlays over asphalt, however, are typically relatively thin and are therefore susceptible to excessive temperature-related stresses, particularly when the existing asphalt is hot from solar heating. If accelerated methods are used, extreme care must be taken to minimize shrinkage cracking through diligent and thorough curing (sometimes at double the ordinary rate of curing compound, or, in short sections, wet curing and/or blankets may be necessary). Some states have incorporated fibers to increase the toughness of the concrete as well as to improve its resistance to cracking.

Determining a reasonable value for opening bond strengths for these types of overlays may prove difficult, as described above. Typically, a value for opening strength of the concrete of 420 psi (2.9 MPa) flexural (2,500 psi [17.2 MPa] compressive) to 480 psi (3.3 MPa) flexural (3,000 psi [20.7 MPa] compressive) has proven adequate. An additional consideration for accelerated construction is to encourage bond via milling of the existing asphalt surface. If shear failures do occur, they will likely occur in the asphalt since concrete shear strength is greater than asphalt shear strength.

Strength Criteria for Opening Unbonded Overlay Systems

Because unbonded overlays are essentially a concrete pavement on a high-quality subbase, it is appropriate and somewhat conservative to use opening strength criteria that are commonly used for conventional paving. For example, a minimum flexural strength (3rd point) of approximately 340 psi (2.3 MPa) or 1,800 psi (12.4 MPa) compressive strength can be used for noninterstate traffic. The state of Georgia for example, uses a concrete open-

ing compressive strength criteria of 1,400 psi (9.7 MPa) compressive strength, anticipating that the approved mixture reaches 2,500 psi (17.2 MPa) in 24 hours and 3,500 psi (24.1 MPa) in 3 days.

Repairs of Concrete Overlays

Concrete overlays can be expected to provide excellent performance and long life. Their performance is directly related to the uniformity and quality of the existing pavement base. Isolated weak or thin spots in the existing pavement may not be discovered during the pavement evaluation, overlay design, or overlay construction phases, and, like all pavement systems, some repairs may be necessary during its service life. If a bonded or unbonded overlay panel becomes distressed, overlay repairs are relatively straightforward and, in many cases, easier to perform than repairs of conventional concrete pavements.



Figure 116. Removing overlay panels (source: Randell Riley, Illinois chapter, ACPA)



Figure 117. Finish and cure of concrete overlay repair (source: Dan DeGraaf, Michigan Concrete Paving Association)

Repairs of Bonded or Thin Unbonded Concrete Overlays

Full-depth panel replacement rather than partial-depth panel replacement is typical for bonded and thin unbonded overlays, because the panels are small and relatively thin. After full-depth sawing of the panel perimeter, the panel can be removed easily by jack hammers or a backhoe; see Figure 116.

When the overlay has been removed, the existing base should be examined. If the old existing pavement is determined to be deficient, it should be removed and replaced with concrete; the pavement replacement may be

placed in a separate layer or poured monolithically with the overlay. Asphalt should not be used as a patching material because concrete does not bond well with new asphalt. Replacing an overlay panel(s) is easily accomplished using typical overlay procedures and materials; see Figure 117.

Thin concrete overlays at the end of their service life can be milled and refilled easily; see Figures 118 and 119. Removal by milling (also referred to as carbide milling, cold planning, and rotomilling) is a good option for concrete overlays, because they rely on the existing pavement base for load transfer and therefore do not typically require steel reinforcement.



Figure 118. Typical concrete pavement milling operation (source: Randell Riley, Illinois chapter, ACPA)



Figure 119. Typical concrete pavement milling operation (source: Dan DeGraaf, Michigan Concrete Paving Association)

Generally, the productivity of milling concrete is very good, depending on aggregate hardness, bit configuration, and removal depth. For example, removal of a concrete overlay at a 2-in. (50-mm) depth has been reported as high as 8,000 ft²/hr (720 m²/hr) and for a 4-in. (100-mm) depth, as low as 2,700 ft²/hr (243 m²/hr).

The method of removal is similar to that used for asphalt layers, particularly when there are no steel tiebars in the overlay.

Milling can be performed under wet or dry conditions. The milling depth can be feathered into adjacent pavements. Milling can be completed on specific selected sections. The coarseness of the surface after milling and the fineness of the millings can vary based on the type and spacing of milling teeth on the drum; see Figure 120.



Figure 120. Typical concrete pavement millings from milling operation (source: Dan DeGraaf, Michigan Concrete Paving Association)

Repairs of Full-Depth Unbonded Concrete Overlays

Full-depth unbonded overlays typically are constructed with dowel basket and lane ties, so common concrete pavement repair techniques are used. These include partial- or full-depth repairs, diamond grinding, and joint resealing. With thicker overlays (8 in. [200 mm]) subject to heavy traffic, load transfer restoration can also be applied to restore load transfer and mitigate joint problems.

When a uniform separation course is used, overlay thickness will likely vary, especially where superelevation changes are encountered; repairs made in these areas may require provisions to account for additional saw-cut depth.

Standard full-depth concrete removal techniques are used on thicker overlays. Eight- to nine-inch (200- to 250-mm) concrete overlays have been successfully removed by milling.

APPENDIX A.

EVALUATION AND SELECTION TABLES

Tables 22 and 23 are tools for evaluating the conditions of concrete pavements and asphalt/composite pavements, respectively.

Table 22. Distress Types and Severity Levels Recommended for Assessing Concrete Pavement Structural Adequacy





Load-Related Distress	Highway Classification	Current Distress Level		
		Adequate	Marginal	Inadequate
Jointed plain concrete medium- and high-severity transverse and longitudinal cracks and corner breaks (% slabs)	Interstate/Freeway	< 5	5 to 10	> 10
	Primary	< 8	8 to 15	> 15
	Secondary	< 10	10 to 20	> 20
Jointed reinforced concrete medium- and high-severity transverse cracks and corner breaks (#/lane-miles)	Interstate/Freeway	< 15	15 to 40	> 40
	Primary	< 20	20 to 50	> 50
	Secondary	< 25	25 to 60	> 60
Jointed plain concrete mean transverse joint/crack faulting (in.)	Interstate/Freeway	< 0.10 (2.5 mm)	0.10–0.15 (2.5–3.8 mm)	> 0.15 (3.8 mm)
	Primary	< 0.125 (3.2 mm)	0.13–0.20 (3.3–5.1 mm)	> 0.20 (5.1 mm)
	Secondary	< 0.15 (3.8 mm)	0.15–0.30 (3.8–7.6 mm)	> 0.30 (7.6 mm)
Jointed reinforced concrete mean transverse joint/crack faulting (in.)	Interstate/Freeway	< 0.15 (3.8 mm)	0.15–0.30 (3.8–7.6 mm)	> 0.30 (7.6 mm)
	Primary	< 0.175 (4.5 mm)	0.18–0.35 (4.6–8.9 mm)	> 0.35 (8.9 mm)
	Secondary	< 0.20 (5.1 mm)	0.20–0.40 (5.1–10.2 mm)	> 0.40 (10.2 mm)
Continuously reinforced concrete medium- and high-severity punchouts (#/lane-miles)	Interstate/Freeway	< 5	5 to 10	> 10
	Primary	< 8	8 to 15	> 15
	Secondary	< 10	10 to 20	> 20
Applicability of Bonded Concrete Overlays				
Applicability of Unbonded Concrete Overlays				

Table 23. Distress Types and Levels Recommended for Assessing Asphalt and Composite Pavement Structural Adequacy

Distress Type	Highway Classification	Distress Level		
		Adequate	Marginal	Inadequate
Fatigue cracking (% of wheel path area)	Interstate/Freeway	< 5	5 to 20	> 20
	Primary	< 10	10 to 45	> 45
	Secondary	< 10	10 to 45	> 45
Longitudinal cracking in wheel path (ft/mi)	Interstate/Freeway	< 265 (50.2 m/km)	265–1060 (50.2–200.8 m/km)	> 1060 (200.8 m/km)
	Primary	< 530 (100.4 m/km)	530–2650 (100.4–501.9 m/km)	> 2650 (501.9 m/km)
	Secondary	< 530 (100.4 m/km)	530–2650 (100.4–501.9 m/km)	> 2650 (501.9 m/km)
Composite pavement reflection cracking crack width (in.)	Interstate/Freeway	< 0.50 (12.7 mm)	0.25–0.50 (6.4–12.7 mm)	> 0.50 (12.7 mm)
	Primary	< 0.50 (12.7 mm)	0.50–0.75 (12.7–19.1 mm)	> 0.75 (19.1 mm)
	Secondary	< 0.50 (12.7 mm)	0.50–0.75 (12.7–19.1 mm)	> 0.75 (19.1 mm)
Transverse crack spacing (ft)	Interstate/Freeway	> 200 (61.0 m)	100–200 (30.5–61.0 m)	< 100 (30.5 m)
	Primary	> 120 (36.6 m)	60–120 (18.3–36.6 m)	< 60 (18.3 m)
	Secondary	> 120 (36.6 m)	60–120 (18.3–36.6 m)	< 60 (18.3 m)
Mean depth of rutting in both wheel paths (in.)	Interstate/Freeway	< 0.25 (6.4 mm)	0.25–0.40 (6.4–10.2 mm)	> 0.40 (10.2 mm)
	Primary	< 0.35 (8.9 mm)	0.35–0.60 (8.9–15.2 mm)	> 0.60 (15.2 mm)
	Secondary	< 0.40 (10.2 mm)	0.40–0.80 (10.2–20.3 mm)	> 0.80 (20.3 mm)
Shoving (% of wheel path area)	Interstate/Freeway	None	1 to 10	> 10
	Primary	< 10	10 to 20	> 20
	Secondary	< 20	20 to 45	> 45
Applicability of Bonded Concrete Overlays				
Applicability of Unbonded Concrete Overlays				

Installation cost is on the order of \$0.50 per yd² (circa 2008)

APPENDIX B.

RECONSTRUCTION OPTIONS FOR CONCRETE

Should the existing asphalt or concrete of a composite pavement section or plain concrete pavement have major deficiencies that cannot be overcome with preservation techniques (i.e., concrete overlays), the existing pavement can be recycled in place to serve as a granular base. The two acceptable methods are as follows:

1. Recycled concrete aggregate (RCA) as base material (preferred option)
2. Rubblization of concrete pavement (only used under certain conditions if severe MRD [ASR or D-cracking] exists or the concrete pavement has failure due to unsta-bilized open graded base)

In-place Recycled Concrete as a Processed Base Material

Recycling concrete pavements into an RCA is a viable alternative for unbound base course construction. To be successfully utilized, recycled concrete must be viewed as a source of aggregate with characteristics and value equivalent to the aggregate material it replaces ton for ton; see Figure 121. The quality of RCA concrete depends on the amount of mortar that remains attached to the original aggregate. If processing is such that little mortar remains and no fines smaller than #4 sieve are used, the properties of the RCA will be similar to the properties of the original aggregate. An RCA, as a rule, is considered a high-

quality material for unbound or stabilized applications such as bases when compared to conventional new aggregate. An RCA has rougher surface texture, higher shear strength, higher rutting resistance, and higher resilient modulus (Van Dam et al. 2012). These exceptional qualities allow for unrestricted use of an RCA as a base material up to and including 100 percent substitution of new aggregate.

It is generally accepted that after unbound RCA base is compacted, its strength and stiffness increase. A misinterpretation of this phenomenon is that this is due to hydration of unhydrated concrete contained within the paste portion of the RCA. Instead, the increased stiffness is credited to the carbonation of very soluble calcium hydroxide (CH) released by the RCA in the presence of moisture, which is constantly available in the subsurface base.

When using RCA as a drainable base, certain contained design conditions must be considered. The mortar fraction of the RCA contains CH as a by-product of concrete hydration, which, when in the presence of water, goes into solution. This solution can react with atmospheric carbon dioxide and form a solid material called tufa (leachate), which, in the presence of fines, can reduce the flow in improperly designed drainage systems using RCA. Conditions that lead to this are easily prevented in drainable bases (Wade et al. 1995). A proper design places all RCA above the water table, below the elevation of the inlet of the drainage system, and, if geotextiles are used, the flow must be parallel to the geotextile and not through it. Improper design will result in the formation of tufa

from the fines and CH, clogging pipes, and other elements of the drainage system.

Effluent from drainable bases containing RCA can have pH values greater than 7.0 due to the leaching of CH. This has not been found to be problematic in ecosystems. Although effluent from an RCA drainable base can have increased pH, especially during the first flushing cycle of water, it has no buffering capacity and is equivalent to adding lime to stabilize the effect of acid rain on a lawn. In stagnant flow conditions, the leachate could reach a pH as high as 12.4; however, this will quickly dissipate as the leachate encounters soils and organic materials commonly present in soils (Van Dam et al. 2012).

Pavements with an MRD such as ASR, D-cracking, or freeze-thaw distress have been effectively used as unbound base material. Before using these materials, however, it is recommended that testing be performed to determine the severity of the ASR in accordance with the FHWA's *Report on the Diagnosis, Prognosis, and Mitigation of Alkali-Silica Reaction (ASR) in Transportation Structures* (FHWA 2010).

Rubblization of Concrete Pavement

Rubblization is a technique that was developed to minimize reflective cracking in HMA overlays. The intent of this technique is to reduce the existing concrete pavement into small sections to prevent reflecting into the HMA overlay; see Figure 122.



Figure 121. Recycled concrete aggregate (source: Jonathan Gene Pitre, University of New Hampshire)



Figure 122. Rubblized concrete pavement (source: Todd Hanson, Iowa DOT)

Rubblization effectively destroys the existing pavement structural condition and reduces the support for the overlay to the least common denominator. It results in the loss of the existing pavement's structural carrying capacity, and thus requires a thicker, more costly overlay.

Rubblization may serve as a base for an unbonded concrete overlay when the existing concrete slab exhibits fast-acting material distress problems such as ASR, D-cracking, or freeze-thaw damage. These material problems cause the concrete pavement to deteriorate and lose structural integrity. Before these pavements are rubblized, however, they should be tested in accordance with the referenced FHWA criteria.

The conditions for rubblization to be considered for a base for an unbonded overlay are concrete pavements that have failed due to unstabilized open graded bases. Many of these pavements have migration of the subgrade material into the open graded base layer, creating voids and differential support conditions. This differential settlement of the open graded layer results in failed support conditions and ultimately mid-panel cracks, corner cracks, and significant faulting.

Rubblizing a concrete pavement successfully is predicated on a number of conditions, and there are several cautions to consider as well when contemplating this technique:

- First and foremost, a complete and uniform rubblization can only be accomplished

when the existing pavement is sitting on a stable subgrade. The rubblization operation must not be allowed to destroy the integrity of the support layers below the pavement. When base is soft, the rubblization process under certain conditions can drive concrete pieces into the subgrade, forcing water upward and reducing subgrade stability. Soft and yielding subgrade conditions result in incomplete and nonuniform rubblization. Moisture/water present under the existing pavement may create a condition that prevents the rubblized concrete particles from seating and locking together. The ability of a particular pavement to withstand rubblization and retain its drainage and support functions is typically not known until the pavement is actually rubblized.

- Prior to rubblization, all HMA surfacing and joint filler material must be removed.
- Underdrains should be installed prior to rubblizing the pavement.
- Care must be taken not to damage utilities or underdrains with minimal cover.
- Rubblization must shatter the existing concrete for the full depth of the pavement. A testing protocol should be established to determine the quality and completeness of the rubblization operation as well as actual gradation.
- Steel reinforcement in the existing pavement should be debonded from the

concrete. Some of the reinforcement may surface during the rubblization operation, and steps should be taken to remove exposed reinforcement.

- An aggregate choke stone layer is required to fill voids and minimize the potential for pavement quantity overruns.

Crack and Seat (Not Recommended)

Crack and seat should be limited to isolated locations like tented panels. It results in a nonuniform support condition when applied over large areas, and this can be problematic for both HMA and concrete overlays.

Crack and seat concrete does not serve well as a subbase for either concrete or asphalt because it has no gradation or density control. During the crack and seat operation, the wire mesh must be severed or the crack that is tied by mesh may cause reflecting cracking into the concrete overlay. The choke stone and crack and seat material must be drained to prevent trapped water. Subgrade support influences the size of the cracked pieces. Presence of water in the subgrade will cause loss of subgrade support, which leads to rocking of the slabs and subsequent distress in the overlay. The quality of the subsurface materials is highly suspect in the same areas that the slabs in the concrete were in very poor condition.

APPENDIX C.

FIBER REINFORCEMENT

Why Fibers?

Fiber reinforcement in concrete overlays (FRC) can increase the concrete structural integrity. It contains short, discrete fibers that are to be uniformly distributed and randomly oriented. The most common of these fibers include synthetic and steel fibers. Synthetics have played a predominant role for the last two decades as the technology has improved. Other fiber types such as glass, cellulose, and natural fibers are occasionally used, but these are relatively rare and are outside the scope of this document; see Figure 123.

Characterization of the fibers with different concrete is normally based on fiber materials, geometries, distribution, and densities. Used in sufficient dosages with uniform distribution, fibers help increase, in engineering terms, the “toughness” and ductility of concrete. Enhancing the toughness and ductility provides some flexibility to the designer, since longer joints and/or thinner sections of concrete can be considered. A good understanding of the several different fiber technologies permits the designer to better optimize designs for specific conditions.

Sufficient fibers provide an additional benefit in controlling differential slab movement because the fibers span the cracked portion below the sawed joints. Plain concrete in overlay applications occasionally exhibits differential movement of the individual slabs as a result of temperature, curling/warping, or

load-induced movement in the underlying pavement. As a result, joints may open up or not line up; this is principally an issue of aesthetics, but it can affect performance when materials and conditions exacerbate curling/warping.

In extreme cases, joints may fault in high-traffic-volume areas. Synthetic fibers have been used successfully in helping to control these problems for several years, although long-term (greater than 15 years) duration of the benefit is not yet well established, particularly for synthetic fibers. Steel fibers have been around much longer and, provided corrosion can be kept in check or is not found to be objectionable on the surface, can be quite effective as well, but they have other disadvantages compared to synthetics.

Fibers have the ability to hold the inevitable cracks tightly together. These cracks can occur from a variety of causes, but the fibers render the cracks more an annoyance than an actual problem. Such tight cracks will usually perform better than typical sawed joints. Good performance across cracks has been observed since fibers have been used in roadway applications. In the concrete plastic state, fibers also offer the advantage of increased resistance to “plastic shrinkage” cracking. This type of cracking can occur in all concrete applications when wind blows across the paved surface and the rate of evaporation exceeds the rate of bleed water coming to the surface of the concrete prior to set.

Types of Fibers

The type of fiber to be used and the recommended dosages for specific types are evolving fairly rapidly. Although steel fibers have a long history in paving applications, their addition to the concrete using current technology requires significant manpower, which raises cost. Steel fibers also require more care to prevent “balling” of the fibers as a result of their tendency to sometimes clump together when exposed to cement and water. The latter problem can be prevented with proper charging of the mixers, which may vary with the other materials in the concrete mixture. Steel fibers are considerably heavier than synthetic fibers and can settle near the bottom of the overlay if not properly mixed.

Synthetic fibers are broadly classed as macro fibers rather than micro fibers, which are also common in the industry. Generally speaking, synthetic fibers have been favored compared to steel fibers in the last few years because of the ease of handling and better dispersion characteristics. The volume of fibers added to a concrete mix is expressed as a percentage of the total volume of the composite (concrete and fibers), termed volume fraction (vf). The vf typically ranges from 0.1 to 3.0 percent. The aspect ratio (l/d) is calculated by dividing fiber length (l) by its diameter (d). Fibers with a noncircular cross section use an equivalent diameter for the calculation of l/d .

Steel fibers with a much higher density than synthetic fibers will weigh much more than synthetic fibers at the same volume in the concrete mixture. It may also, however, take a higher volume of one fiber compared to another to provide the same increase in pavement performance. For this reason, it is important to know the type of fiber being used, the volume of the fiber needed in the mixture to produce the desired properties, and the fiber’s specific gravity. This information is essential so that the concrete producer, who batches concrete by weight rather than volume, can produce a unit volume of concrete having the appropriate behavior characteristics upon setting.

Macro synthetic fibers starting at a minimum dosage of 4 lb/yd³ have worked well on concrete overlays where they have been used. For a typical concrete mix, this is about 0.26 percent volume. For comparison, the same volume of steel fibers would weigh about 34 lb/yd³ but yield somewhat different char-



Figure 123. Fibers in concrete mix (source: Randell Riley, Illinois chapter, ACPA)

acteristics in the concrete. Fiber producers and suppliers can be of assistance in this area since, as mentioned earlier, the technology is undergoing a rapid evolutionary phase. Various blends of fiber technologies are being introduced that combine steel and synthetic fibers. Also, higher modulus synthetics are under development that may further advance the technology in the next few years. A good reference and some minimum recommended dosages for a specific class of fiber based on the current state of understanding can be found at www.dot.state.il.us/materials/syntheticfibers.pdf (IDOT-BMPR 2013).

High-volume Macro Synthetic Fiber Mixtures

Certain types of macro synthetic fibers in quantities greater than that mentioned earlier can provide for reduction in overlay thickness, enhance postcrack flexural performance, and, in some cases under high doses, actually allow the concrete to become yielding in nature and to flex somewhat under loads. Work still needs to be done to better define the optimal amount of macro synthetic fibers to add or the optimal performance volume, based on current records of thin pavements with FRC.

The 4 lb/yd³ dosage mentioned earlier is enough to impart the proper characteristics in hardened concrete to improve postcracking performance and increase the load-carrying capacity of the entire slab. Higher dosages can further improve this performance, but care must be taken to avoid clumping of the fibers in the mix. Mix adjustments such as changing aggregate gradation, cement content, and admixture type and dosage are necessary to accommodate the higher fiber contents. Concrete mixtures with a high volume (5.0 to 7.5 lb/yd³) of macro synthetic fibers (typically with lengths of 1.5 to 2.25 inches) ideally should utilize well-graded aggregates. In addition, because of the fibers' large surface area compared to their volume, such mixtures may require slightly more cementitious material (20 to 50 lb/yd³) and slightly more water to keep the same w/cm ratio; they also may require adjustment to the amount of fine aggregates.

Research on a concrete overlay wearing surface using high fiber content was conducted by Dr. Amanda Bordelon at the University of Illinois, and published as Flowable Fibrous Concrete for Thin Pavement Inlays (wearable surface) (Bordelon 2011). A flowable fibrous concrete (FFC) mixture with high workability was developed, to be placed rapidly as a 2-inch (5-cm) thick concrete overlay or inlay. To extend the service life of the thin overlay

(or inlay) through improved crack resistance and improved residual load-carrying capacity, the mixture contained higher macro-fiber content (up to 0.5 percent by volume). To retain workability at these higher fiber contents, the mixture required a higher content of cementitious material in order to coat the fibers.

For example, a cementitious material content of around 790 pounds/yd³ was utilized for achieving twice the fracture toughness with 0.56 percent volume fraction of fiber content. In addition, other material proportions were found to enhance the mixture's workability and stability against segregation:

- Smaller maximum coarse aggregate size, such as less than 3/8 inch (9.5 mm), in order to be placed as a 2-inch (50-mm) overlay or inlay
- Higher percentage of sand
- Use of micro-fiber
- Use of a high-range water reducer

A 325-foot long full-scale FFC inlay was constructed in 2009 in Rantoul, Illinois, to demonstrate and observe any challenges related to the placement of the FFC material and to monitor the cracking and bonding performance of the hardened concrete pavement inlay. The 2-inch FFC inlay sections were cast on a milled asphalt pavement in good condition and demonstrated good bond strength between layers. The residual strength ratio of the mixture was measured between 40–50 percent, which was at least twice as high as recommended in the standard BCOA calculator. Different size slab panels were attempted at 4 feet, 5.5 feet, and 11 feet in the longitudinal direction. The widest transverse joint was around 0.05 inches (1.25 mm), and the average joint crack remained tight at 0.016 inches (0.4 mm) for the 4-foot slab size.



Construction Considerations When Using Fibers

The fibers' length and large volume will often reduce slump from 4 inches to 2 inches in a concrete mixture. With everything else being equal, there is not a corresponding reduction in workability. To a concrete finisher or ready-mix concrete truck driver casually observing the discharge of the first load of concrete, this can trigger their natural instinct to add water to the mixture to make it easier to place. In reality, an appropriately designed and batched concrete and suitable fiber will actually place similarly to normal concrete and responds especially well to mechanical vibration; if needed, a moderate dose of a polycarboxylate or other water reducer typically is used to offset any loss in workability, especially for fiber dosages 5.0 lb/yd³ and greater. The admixture supplier should be contacted for recommendations. During construction, a few other items may warrant attention when using fibers, and these characteristics are further exacerbated as the dosage of fibers increases:

- Fibers can be added at the batch plant or placed in the ready-mix truck; see Figure 124.
- Fiber use may require slightly delayed contraction joint sawing due to the fibers' tendency to increase susceptibility to joint raveling if not timed properly.
- The use of macro fibers adds costs to the concrete mixture. For this reason, their use must be weighed against other costs and factors such as increasing the overlay thickness without the fibers, possible reduced number of sawed joints, better joint performance, ability to minimize grade changes, and benefits of increased design life. The



Figure 124. Fibers added at plant (left) and bags tossed into ready-mix truck (right) (source: Randell Riley, Illinois chapter, ACPA)

price of synthetic fibers can increase materials costs +/- \$0.08/ft² (\$0.70/yd²) per inch based on a 4.0-lb dosage/yd³. The increase in cost is, however, significantly driven by the size of the project and the volume of fibers being used; large projects can cost less and small projects can be more than this amount based on 2012 prices.

- Macro fibers can negatively affect the finish appearance compared to concrete without fibers, if care is not taken with the fiber type, mix design, and texturing technique; however, with proper care, the finish appearance will be acceptable. Owners need to be made aware up front that the concrete surface will appear slightly different than the clean smooth surface usually expected of concrete paving. Some contractors will pan finish the surface to embed the fibers prior to texturing. This is not recommended since the humidity, wind, sun, shade, temperature, and rain can all affect this operation; furthermore, if the panning is not properly done, a significant amount of the entrained air can be removed, thereby reducing the concrete freeze-thaw durability. The “hairy” surface can occur with fiber volume rates near 0.5 percent or more if the care noted above is not taken; see Figure 125.
- Heavy doses of macro fiber can make the surface more difficult to keep clean because of the slight roughness created by each fiber

that manages to find its way up through the surface. If this dosage rate is reduced back down to maybe 0.2 to 0.4 percent, the FRC can be easier to finish. Over time, the fiber itself will wear away and disappear, but the small roughness immediately around the fiber may be evident. This is not something that is noticed at highway speeds, but for pedestrians walking across commercial applications, it can be evident. If it is objectionable, it can be removed using a simple pan flame torch.

- Often skid-resistant or higher-friction surfaces are specified for paving applications. Some fibers can create unsightly finishes depending on which fiber and dosage amount are chosen. With the addition of fibers, it is more difficult to get a good broom finish. Generally, an acceptable broom finish can be achieved with a proper mix design, suitable fiber, appropriate broom kept relatively clean, one-directional broom passes, and no “jiggling” of the broom.
- Unless care is taken to prevent them, macro fibers may occasionally ball up and create a surface defect even if added to the ready-mix discharge load under the utmost care; see Figure 126.
- Some contractors drill out the “hair balls” with a 4-inch core drill to a depth of an inch or so. This allows for the hair ball to be removed and replaced with a grout or concrete mixture.

- Do not place or finish if rain is eminent because surface water will make the fibers more prominent.
- Limit the use of older types of high-range water reducers (HRWRs) (naphthalenes and melamines) to reduce the water-cement ratio, as they tend to bleed and exacerbate spotty concrete setting, thereby possibly causing fibers to be more prominent. The newer HRWR (polycarboxylates) are generally better and reduce segregation effects in the mixture (both fiber and aggregate related).
- Some solvent-based curing compounds will make the fibers more prominent.
- Finally, know the product you are using. The use of fibers is an excellent tool for enhancing concrete overlays, but the products are rapidly evolving and many owners, contractors, and producers are still learning how to best apply the technology. When using macro synthetic fibers, a trial mix should be batched and placed at the ready-mix producer’s facility or placed elsewhere using the ingredients and proportions approved for the project so that all know and understand what is expected. Communication with the owner, general contractor, and inspectors is important to let them know what to expect during and after construction. It is important to understand the fiber product being used.



Figure 125. Finished concrete overlay with synthetic fibers

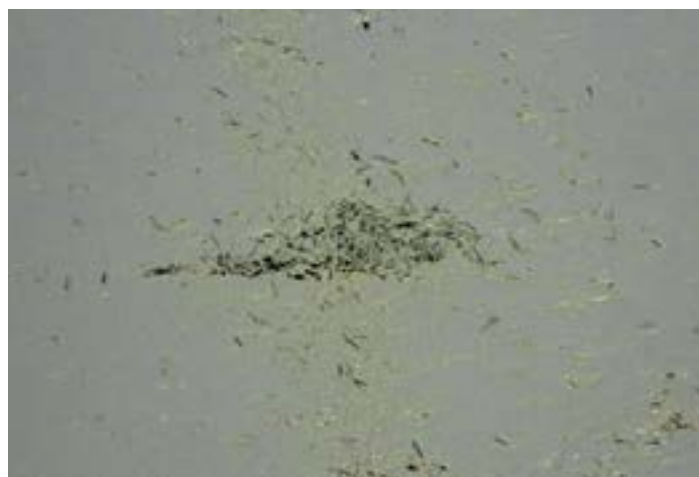

Figure 126. Balling fibers

APPENDIX D.

LASER SCANNING SURVEY

Roadway Surface 3-D Laser Scanning

One of the problems experienced with concrete overlays is minimizing quantity overruns due to the lack of survey of the existing pavement. The advent of laser scanning has opened a new avenue for mapping of pavement surfaces before overlay construction to help eliminate excessive overruns. To date, pavement surface mapping has been done with conventional survey equipment such as a total station, rod and level, GPS rover unit, or vertical (looking down) sonic units that double as profile measuring devices. These methods are labor intensive and often require traffic control to obtain the data. Laser scanning can offer reduction in survey cost, savings in time, and less interference to the traveling public.

Scanning Applications to Pavements

Either static or mobile scanning will provide a map of the surface of the roadway. Most mobile units are developed to look at the

area ahead or behind the vehicle at a predetermined vertical angle. These are designed to gather large amounts of data from right-of-way to right-of-way as well as high-quality digital photo images so closely spaced that it is similar to a video. They are a step forward from the traditional photolog van that provides basic “relative” elevations on the pavement, but they are not sufficient for controlling concrete yield.

The type of laser from the traditional photolog van relevant to pavement overlays is that contained in the units currently used to measure finished pavement profile. These are downward-looking lasers (perpendicular to the surface) and are used to measure pavement surface texture or a very narrow profile line. The type of laser (bandwidth) and the height of the laser are used to measure a very fine line or area of the surface.

Mobile lasers and those used for pavement profiling are usually not found on the same unit. Mobile lasers should be mounted as high as possible on the unit to see over obstructions, and the profiling type laser units are mounted at bumper height or lower to maximize accuracy and minimize light interference.

Planning Items to Be Considered

Preplanning of the GPS control-point measurements along the roadway or the use of known points throughout the project corridor should be done with care to assure that the amount of data is adequate for the accuracy desired. The scan data is only as accurate as the control-point data.

Traffic interference can be a problem with static scans from the shoulder of the road. This can be overcome with proper planning and the fact that multiple scans will find the gap in the traffic. The same goes with mobile scanning; using additional vehicles for blocking and considerations to time of day for off-peak traffic is beneficial.

Sun angles can impact the photo quality. This item requires that the operators use the sun angle to their advantage in determining what to scan and when during the day.

Scan runs can be arranged in the planning phase to collect all the mainline data in one pass and the ramps or exits in a second or separate pass if the distances from the mainline become too great.

Start and stop areas need to be identified both on paper and on the ground to assure that all possible data is collected in one visit to the site.

Data Analysis

Figure 127 provides a step process of the elements involved with 3-D scanning. The larger portion of the scanning survey process, regardless of static or mobile data collection, is carried out in the office. The office processing consists of establishing a digital terrain model (DTM) at accuracies unachievable via conventional survey methods. With scanning,

the transportation engineer or technician can now see a grid of 0.5 to 1.0 foot, as shown in Figure 128. This will allow detection of various types of pavement failures that were previously not visible and enable highly accurate concrete quantity measurements. Data filtering systems and other routines have been developed to assist in the analysis and extraction of data from the point clouds for specific purposes, such as pavement rehabilitation,

and still preserve the original data set for future uses and historical documentation. An example of this is shown in Figure 129 and shows cross sections that provide data on rutting across the slab and extent of deterioration in the longitudinal direction, which can be measured from the data. The edited data can then be output in CAD or geographic information systems (GIS) files to meet the need of the user.

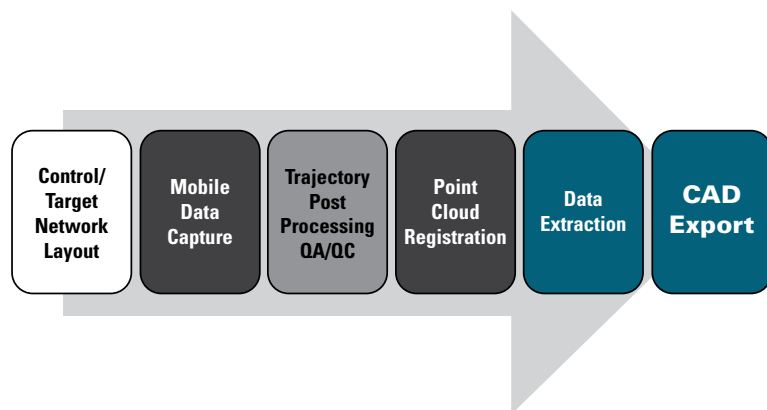

Figure 127. Typical mobile scan project workflow

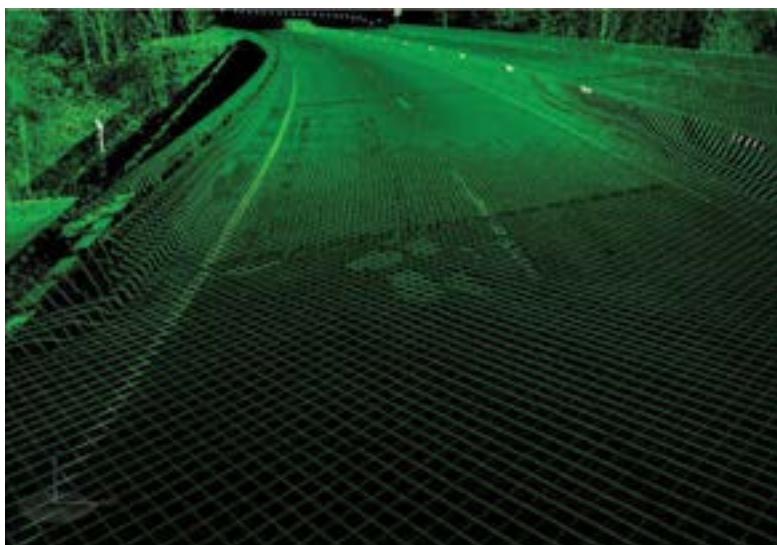

Figure 128. Pavement DTM/detail

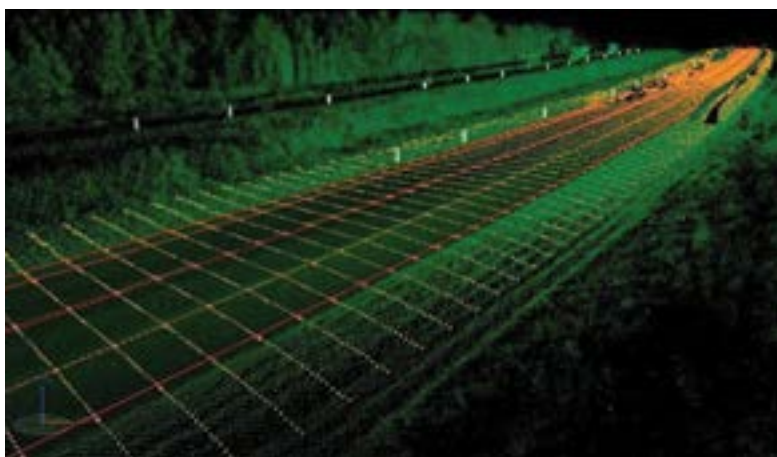

Figure 129. Pavement cross section detail

Static Scanning Operation

Scanning can be performed in a static mode by placing a unit such as the one seen in Figure 130 in a position so that it can reference itself to at least two or more known points of X,Y,Z coordinates. Control is critical in the use of this device, just as in other surveying techniques. Referencing to three or more known points or setting a geometrically sound control system along the project corridor is highly recommended to increase the accuracy of the data. A network of control points 250 to 300 feet apart should be used to establish the control system.

With the inclusion of the laser and camera, this device resembles a “Total Station on Steroids.” This device operates in a 360° radius to gather object and photo data. It locates itself relative to the earth by sighting two or more points of known location (X,Y) and elevation (Z). In roadway scanning, these points are part of a survey traverse. This type of scan requires planning for a traverse of control points and locations of scans in order not to be put in a position of missing key data in a scan by shadows or objects.

The static system can be used to survey pavements from the shoulder for a distance of up to 250 to 300 feet in radius, depending on conditions from the survey unit.

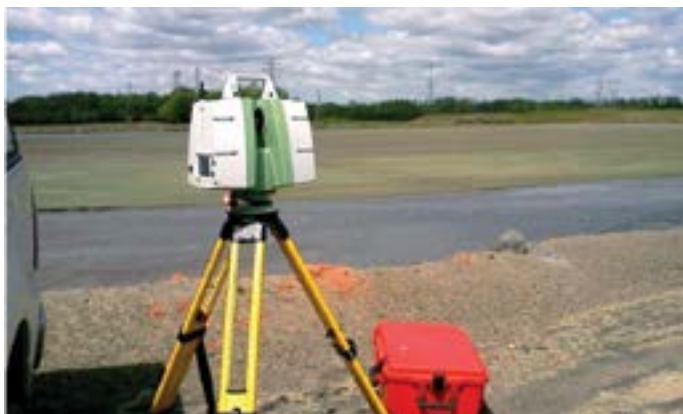

Figure 130. Static laser scanner

Mobile 3-D Laser Scanning

Laser scanning is basically several existing technologies combined into one unit or process. At the heart of the unit is the light detection and ranging scanner, which measures the flight time of a beam of light to calculate the range to objects at predetermined angular increments, resulting in a very large point data set referred to as a “Point Cloud.” The laser scanner conducts measurements to targets, and a 360° camera is used to assist in identifying objects in the scan. The unit also includes a GPS to record its position on the earth’s surface at any time and the relative position of the objects being scanned. An IMU is used to account for movement (pitch, roll, and yaw) in the survey vehicle. A DMI is used to compute wheel rotation and measurements to aid the process. The system is capable of repeatable 0.04- to 0.12-inch accuracy in measurements.

Mobile Mapping Operations

This system allows the surveyor to collect data at highway speeds in a single pass without being a traffic hazard. The equipment is synchronized to allow multiple sensors to feed data on the targeted road surface simultaneously. It does require the equipment used for storage to handle terabytes of information in short periods of time. This system also picks up right-of-way hardware such as above-ground utilities and other infrastructure devices that can be problems in construction if not identified in the planning process (anything you can see is collected). One such device developed is shown in Figure 131.

This device can gather 600,000 to 1,000,000 points per second and capture photos at 3- to 10-foot intervals to give you a stereo view of the front, sides, and downward-looking photos of the pavement at the back. The IMU, GPS, and DMI units gather all the data about the pavement and surrounding area in one pass. This unit is controlled from the view shown in Figure 132 and allows quality control of the data collection on the fly.



Figure 131. Mobile laser scanner



Figure 132. Mobile scanner onboard quality control operation area

APPENDIX E.

FACTORS FOR CONSTRUCTING CONCRETE OVERLAYS UNDER TRAFFIC

Table 24 provides information about various considerations when constructing concrete overlays under traffic.

Table 24. Considerations for Concrete Overlay Construction under Traffic

Factors to Consider	Objectives / Expectations	Considerations / Limitations
Incentives/Disincentives	An effective way of managing successful accelerated construction is to offer its incentives for the contractor. If the schedule is very critical, the contractor may likely consider innovative pavement techniques to complete the project on time or even ahead of schedule. The use of incentives also allows for a better competitive bidding environment for the owner.	Incentives and disincentives should be considered for the project to encourage the contractor to perform within the given schedule when a competitive bidding environment is expected. Use of disincentives should not deter potential bidders when the schedule is critical.
Grade Control	<p>Grade control for the project should be considered early. In the planning of the project, the type of overlay and existing pavement conditions will often dictate the level of survey required for the design and stakeout of the project. Resurfacing projects historically have required little in the way of surveying. A vast number of them are even constructed without detailed construction plans; they are referred to in many states as log jobs. When concrete is used as the resurfacing material, there is no need to increase the level of surveying required on a project.</p> <p>With all resurfacing projects, it is advisable to visit the project site during a rain event and verify that there is no drainage issue. A drive through the project at the posted speed limit will alert you to adverse cross-slope issues. For rural areas, surveying is only required when you determine that there is some type of a drainage, cross-slope, or profile issue that needs to be corrected.</p> <p>The elevation of the concrete paver can be controlled by either a traveling ski or by a stringline that is referenced from the existing pavement. When stringline control is used, establish grades at each stringline pin by projecting the existing cross-slope, sight the string longitudinally, and adjust individual grades up to produce a smooth profile.</p>	<p>If payment is based on the plan area, then the contractor may want a more detailed survey and additional cross sections to ensure proper thickness and yield. If the payment is based on the volume of concrete supplied and the area paved, less survey is required.</p> <p>When milling machines are used to remove existing pavement, it is advisable to have them either follow the same control as the concrete paver or wait to establish the paving control until the milling has been completed.</p> <p>One point of caution for multi-lane construction is that on many pavements, the cross-slope of each existing lane may differ, and the paver should have crowning adjustment capability located at the intermediate lane lines or actively remove any cross-slope differences between the lanes with the milling operation.</p>
Materials/Mixtures		
Reliability of Material Supply	All materials that are required on the project need to be available or scheduled or properly stored for use prior to constructing the overlay project.	Materials that are prone to delivery delays need to be stockpiled.
Material Schedule	Under an accelerated schedule, there is little time for deviation from the intended plan. As such, representative samples from all material supplies should be made with proper certification.	Contingency plans need to be developed to address potential changes in critical material properties.
Concrete Mixture	Normal concrete paving mixtures are typically used for concrete overlay projects. Rapid strength gain to meet accelerated construction schedules does not require special blended cements or sophisticated material. It is possible to proportion a mixture using locally available aggregates, type I and type II cements, SCMs, and certain admixtures. Some initial adjustments will probably be required by the paving crew as they become accustomed to the mixture characteristics.	The mixture needs to match the opening requirements and construction methods to obtain opening requirements. However, the mixture should not be accelerated to a point where there is a high probability of early-age cracking from shrinkage and curling and warping. Each crew member will have to be accustomed to the accelerated duties that accompany expedited construction.

Table 24. Considerations for Concrete Overlay Construction under Traffic, continued

Factors to Consider	Objectives / Expectations	Considerations / Limitations
Cementitious Materials	Hydraulic cements include portland cement and blended cements which contain SCMs. Other types of hydraulic cements are rapid-setting calcium sulfo-alumina cements used for repair materials or for pavements where fast turnaround times are critical. Cements and SCMs play a major role in both heat and strength development, and these properties depend on the interaction of the individual compounds that constitute the mixture.	The Integrated Materials and Construction Practices for Concrete Pavement Manual (IMCP Manual) is a very good reference in order to understand the importance of the proper blend of cementitious materials.
Type I/II Cements	Type I/II cements can reach opening strength without increasing the risk of shrinkage cracks.	More cement does not necessarily mean higher strength but it does increase shrinkage, as well as curling and warping.
Slag Cement	Slag cement can reduce ASR expansion, increase long-term strength, reduce permeability, reduce concrete temperature, and slow hydration.	Slag cement may reduce rate of strength gain and hydration rate.
Fly ash	Fly ash will increase long-term strength, reduce permeability, and reduce set temperature. Some fly ash can slow hydration on accelerated construction projects.	In the past, some states impose restrictions on the use of fly ash in cold weather and may restrict the use of fly ash to 10% on accelerated construction projects even in warm weather months. Mixtures should be tested in the lab to determine the appropriate replacement rates and temperature restrictions.
Type C	Type C fly ash will increase long-term strength and reduce water demand and permeability. This may or may not slow hydration or reduce ASR expansion.	Type C fly ash can affect strength gain. Mixtures must be tested to determine how much class C fly ash is required to reduce ASR-related expansion. Too high a dosage may increase the risk of rapid stiffening and/or damage due to salt scaling.
Type F	Type F fly ash will increase long-term strength and reduce permeability. It will also slow hydration and mitigate ASR expansion.	Type F fly ash delays setting and reduces rate of strength gain. High loss-on-ignition affects air entrainment. Type F is generally effective at reducing ASR-related expansion. Availability may be a limitation.
Chemical Admixtures	Chemical admixtures are added to the concrete mixtures to modify certain concrete properties such as strength. Adding chemical admixtures can achieve these properties more efficiently than adjusting other mixture ingredients such as the type of cement. Admixtures that are combined and contain both water reducers and accelerators are available.	The effects of set-modifying admixtures on other properties of concrete, like shrinkage, may not be predictable. Therefore, acceptance tests of set modifiers should be made with job materials under anticipated job conditions. Compatibility of the admixtures with other ingredients should be tested as it relates to potential constructibility problems.
Water reducers	Water reducers can reduce water demand through reduced paste content (lowers w/cm) to help minimize shrinkage, temperature, and cracking without sacrificing workability. Water reducing admixtures can also increase early strength gain by lowering the quantity of water necessary for cement hydration (by as much as 10% in 28 days). The w/cm ratio typically are at or lower than 0.43 for accelerated construction.	Confirm that water reducers are compatible with other chemical admixtures and cements, particularly under harsh environmental conditions. Confirmed laboratory testing is essential to determine if the admixtures will develop the desirable properties. Type F and G water reducers (superplasticizers) are not normally used in pavements because of their high cost and because it is difficult to control the slump range required for slipform paving with their use. Overdoses of water reducers, particularly normal-range products, may severely retard or prevent setting.
Accelerators	Accelerating admixtures are used to increase the rate of strength development of concrete at an early age, including in cold weather. It is important to test both fresh and hardened concrete properties before using accelerators in overlays, particularly bonded overlays.	Long-term strength may be lower. Excess acceleration may result in cracking before finishing and/or saw cutting can be completed. Care must be exercised in using accelerators in thin overlays so as not to cause early shrinkage, cracking, and high curling and warping.
Air entrainment	Air entrainment will dramatically improve the durability of concrete exposed to moisture during cycles of freezing and thawing. It improves concrete resistance to surface scaling caused by chemical deicers. It also tends to improve the workability of concrete mixtures, reduce water demand, and decrease mixture segregation and bleeding.	Need to check compatibility with other admixtures. For about every 1% of air entrained, about 5% of concrete compressive strength is lost. Loss of air through the paver is acceptable up to 1.50% to 1.75%. However, when the loss of air through the paver approaches 3%, the air system (quantity and distribution) is not acceptable.

Table 24. Considerations for Concrete Overlay Construction under Traffic, continued

Factors to Consider	Objectives / Expectations	Considerations / Limitations
Retarders	Retarders are useful in extending set times. They increase the bleeding rate and capacity and may be accompanied by some reduction in early-age strength gain (one to three days) but higher later strengths.	Retarders delay early strength gain, but do not change workability properties. Under certain conditions, retarders can cause early stiffening and reduce workability.
Aggregates	It is critical that aggregates be well graded (that is, there should be a wide range of aggregate sizes). Well-graded aggregates have less space between aggregate particles, therefore reducing paste demand without loss of workability. Reduced paste content reduces shrinkage and early-age cracking, particularly with accelerated mixes. With all construction, aggregate moisture content needs to be constantly monitored since it can change significantly during the course of construction. Physical properties of the aggregate such as absorption may be one source of change.	An aggregate's CTE is a measure of how much the material changes in length (or volume) for a given change in temperature. For bonded overlays over concrete, use aggregates that as closely as possible matches the underlying pavement CTE. The material is subject to varying conditions in storage and handling. At the very least, these changes should be anticipated, and accommodations made to adjust the water content in the mixture as necessary. Ideally, real-time monitoring of the aggregate moisture content would allow for "on the fly" changes. In most circumstances, a well-regulated sampling program using rapid evaluation equipment will improve this component of the process considerably.
Separation Layer	A separation layer provides a necessary separation plane between overlay and underlying pavement. For asphalt separation layers under pavements carrying heavy truck traffic, decrease sand content and increase 0.13 in. (3.3 mm) aggregate in order to reduce stripping the asphalt due to pore pressure.	A separation layer does not provide structural support. Heavy truck traffic may decrease stability and strip the asphalt due to pore pressure. Consider drainable asphalt layer and drainage system under heavy truck traffic. Geotextiles may also be used as a separation layer.
Fibers	Although not typically required for concrete overlays, consideration needs to be given to the use of fibers for thinner overlays (4" or less). Fibers improve the toughness of the concrete overlay and resistance to plastic and dry shrinkage cracking, particularly with bonded overlays. Fibers also can increase the flexural strength of the concrete.	Placement of fibers in the mixture must be accomplished so as to prevent balling of the fibers into clumps. In some cases, water-soluble bags are added to the final batch. A staging area may be needed with adequate capacity to avoid a queue. In other cases, individual (bulk) fibers may be introduced into the mixture, where a blower appropriate to the application should then be considered.
Batching	Batching of concrete used in concrete overlays is usually no different from conventional concrete paving, or even other ready-mix applications.	Depending on the size of the job, a dedicated mobile batch plant is a benefit to the project. In fact, this is recommended when at all possible due to the potential for increased concrete uniformity.
Capacity	Having adequate batching capacity is a critical link in the process of constructing concrete overlays. Both mixing time and the availability of transport equipment should be balanced along with cost.	Contingency plans should include preparation for rapid responses (repairs) of the more common equipment malfunctions
Consistency	During batching, consistency and uniformity are critical. Adequate mixing time should be balanced with the need for increased production rates. If possible, a continuous type or high-speed twin-shaft mixer could be used to accommodate both objectives.	Overlays are particularly vulnerable to changes in material properties due to their commonly thin sections.
Concrete Transportation		
Traffic Separation	In an ideal situation, a separation of the transit vehicles from both the traveling public and other construction vehicles is helpful.	In most situations, however, circumstances deviate from the ideal, which warrants appropriate measures to ensure continuous, uninterrupted delivery.
Transit Time	Transit time is one variable that must be known. If a mobile batch plant is used, transport of the concrete from the batch plant to the paver may be quick. As a result, deviations from a conventional concrete mixture (including the admixtures that are used) may not be necessary. However, if there is a potential for delay (e.g., due to traffic congestion), or if a ready-mix plant is used for supply with a longer travel time, a modified mixture may be necessary.	Caution must be exercised if a retarder is used as it may also affect the strength gain of the mixture, thus affecting the time of opening to traffic. Curing may also become more critical in these situations as fresh concrete will be exposed for longer.
Protection	Protection of the mixture from environmental factors may also be a consideration, particularly in long transit times	Dry and windy conditions can lead to rapid moisture loss from any exposed concrete. Conditions that are marginal for the risk of freezing or rain must also be addressed. In each case, protection of the concrete in transit may be warranted, and can often be done by use of tarps. If ready-mix trucks are used, protection is often less critical as the concrete is protected by the drum.

Table 24. Considerations for Concrete Overlay Construction under Traffic, continued

Factors to Consider	Objectives / Expectations	Considerations / Limitations
Haul Roads	The condition of the haul roads is another consideration when constructing concrete overlays.	Care must be taken to ensure that the repeated heavy axles of the trucks will not excessively rut the haul road. Evaluation of a haul road in questionable areas should be done prior to the first batching.
Preoverlay Repairs	Prior to the construction of overlays, there may be a need for a variety of spot repairs on the existing pavement to be overlaid. The timing of these repairs will affect the schedule of the overlay construction.	If the preoverlay repairs dictate the accelerated overlay schedule, the repairs should be considered under a separate project or completed in off-peak hours.
Dowel Bar Retrofit	Typically, dowel bar retrofit is not done in conjunction with unbonded overlays since both can serve many of the same functions. Dowel bars have been used in conjunction with thin bonded overlays when you want to significantly increase load-carrying capacity. Good candidate projects for dowel bar retrofits have the following characteristics: pavements with adequate slab thickness, but showing significant loss of load transfer due to lack of dowels, poor aggregate interlock, or subbase/subgrade erosion. Relatively young pavements, because of insufficient slab thickness, excessive joint spacing, inadequate steel reinforcement at transverse cracks, and/or inadequate joint load transfer, are at risk of developing faulting, working cracks, and corner cracks unless the load transfer is improved. Typically, 3 to 5 smooth round steel dowel bars are used in each wheel path.	Slots should be cut by special diamond slot cutters that are capable of making multiple cuts at a time. Modified milling machines are not recommended due to associated spalling and variable cut widths that effect chair width requirements. Slots should be cut parallel with the direction of traffic. To properly prepare the slots, material should be removed with a lightweight jackhammer, and the slot should be sandblasted and cleaned. Re-establish the working joint with a joint insert. When choosing a repair material, select a material with the following characteristics: little or no shrinkage, good ultimate strength, thermal compatibility, freeze-thaw durability, and good bond to existing concrete.
Drainage	Drainage improvements are sometimes warranted to complement the construction of a concrete overlay. These improvements may include cleaning adjacent ditches, increasing their capacity, or even retrofitting subdrains.	Since the equipment used for drainage improvements often works on or near the pavement edge, their operation before the overlay is complete would decrease the likelihood of premature damage to the young concrete but also results in less stable material under the track line, thereby risking reduced smoothness. In addition, if retrofit subdrains are to stabilize the subbase, they should ideally be installed prior to the overlay in order to reduce movement of the existing pavement. However, be careful not to damage the subdrains during overlay construction.
Utilities	Utility work is also sometimes done prior to overlay construction. This may include relocation of utilities from beneath the pavement to off of the pavement edge. If trenching or other disturbance of the existing pavement is required, care should be taken to ensure proper construction of patches.	New patches can be particularly troublesome as they may not have adequate time to "settle" prior to the overlay construction. As with drainage improvements, all utility work should be completed prior to the overlay in order to minimize interference or early-age damage.
Spot Repairs	Some concrete overlays will require spot preoverlay repair to the existing concrete or asphalt pavement structure. If there are extensive repairs, the roadway may not be a good candidate for an overlay.	In all cases, quality of the spot repairs will often be critical to the success of the performance of the pavement.
Partial-depth repairs	Good candidates are sections where slab deterioration is contained to the upper one-third of the slab and where the existing load transfer devices (if any) are still effective.	Poor candidates for partial depth repairs are those with distress caused by compressive stress buildup in long-jointed pavements, spalling caused by dowel bar misalignment or lockup, transverse or longitudinal cracking caused by improper joint construction techniques, working transverse or longitudinal cracks, and spalls caused by D-cracking or reactive aggregate. It is important to verify that all delaminated concrete is removed, and that no concrete around the repair boundaries has been damaged during the process. For bonded overlays, it may be possible to fill in the partial depth repair areas as a part of the overlay paving operation.
Full-depth repairs	Full-depth repairs of existing concrete or asphalt pavements are effective at correcting many different types of localized distress. However, there are a few cases that limit the effectiveness of a full-depth repair.	The effectiveness of a repair is dependent on the proper sizing of the repair. Most agencies specify a repair with a minimum length of 4 to 6 ft (1.2 to 1.8 m). Salvaging the existing dowel system is not recommended. It is also important to verify that all delaminated concrete is removed, and that no concrete around the repair boundaries has been damaged during the process.

Table 24. Considerations for Concrete Overlay Construction under Traffic, continued

Factors to Consider	Objectives / Expectations	Considerations / Limitations
Retrofitted edge drains	A good candidate project for retrofitted edge drains is a pavement that is showing early signs of moisture damage, is relatively young (i.e., less than 10 years old), and is only exhibiting a minimal amount of cracking (less than 5% cracked slabs) (Mathis 1990; FHWA 1992). Many studies have concluded that retrofitted edge drains are not effective at prolonging the service life of pavements that have already experienced significant moisture-related deterioration (Wells and Wiley 1987; Young 1990; VDOT 1990).	Retrofitted edge drains are not recommended on pavements where base contains more than 15% to 20% fines. However, they may be used in these types of soils to provide a drainage pathway for separation layers used in unbonded overlays. When placing corrugated polyethylene pipes, extra care is also required to prevent overstretching of the pipes during installation. To avoid damage to the pipes during compaction, a minimum of 6 in. (150 mm) of cover over the drainage pipe is recommended before compacting.
Slab stabilization	Slab stabilization restores support beneath concrete slabs, thereby reducing progression of support-related distresses such as pumping, joint faulting, and corner breaks. Slab stabilization is not intended to raise depressed or settled slabs to the desired elevation. Cement grout mixtures and polyurethane are the most commonly used materials.	Watch the maximum pressure to make sure it does not exceed 100 psi (0.69 MPa). Monitor slab lift closely. Lift is typically limited to < 0.13 in. (3.3 mm). Stop grout injection when the grout is seen flowing from holes, cracks, or joints. Stop injection if one minute has elapsed, regardless of pressure or lift changes.
Surface Preparation/Cleaning	Surface preparation and cleaning are required to prepare the existing surface for the concrete overlay.	The techniques used will vary depending on the surface type. The equipment used for repair should be sized to provide not only adequate production rates but also to minimize the disruption to the traveling public and to assist with the accelerated schedule.
Traffic on Prepared Surface	Phasing of the surface preparation operation can allow for intermediate trafficking of the surface prior to the overlay placement.	If trafficking is allowed on the prepared surface prior to the paving of the overlay, subsequent cleaning of the surface, particularly for bonded overlays, is required in order to remove any potential contamination.
Bond on Concrete	Existing pavement surface preparation typically consists of shotblasting followed by sweeping the concrete surface. Cleaning consists of compressed air.	Paving should commence soon after cleaning (i.e. minutes) to minimize the chance of contamination of the surface. Milling is used to lower the concrete elevation where required and is not used as a concrete surface preparation by itself since it can cause surface microcracking and fracturing of the exposed aggregate.
Bond on Asphalt	Existing pavement milling may be used where surface distortions are 2 in. (50 mm) or greater to remove soft asphaltic material that would result in inadequate bond surface or to roughen the surface to enhance bond development. Cleaning consists of sweeping the asphalt surface then cleaning with compressed air.	Water or moisture cannot be allowed to stand on the asphalt surface prior to the bonding resurfacing. In order to prevent contamination of the surface, it is important to avoid a large lag time between the final surface cleaning and paving.
Unbonded on Concrete	Only the distresses that cause a major loss of structural capacity require repair.	The existing pavement needs to be stable and not shifting or moving, particularly at the subbase level.
Unbonded on Asphalt	Milling may be used where surface distortions are 2 in. (50 mm) or greater to remove distortions that contain soft or fractured asphalt. Before concrete placement, the asphalt surface should be swept. Remaining small particles are not considered a problem.	Spot milling of only parts of the projects with significant distortions or structural problems is often adequate.
Traffic Considerations		
Vehicle Access	Meet needs of user. May want to open pavement to cars earlier and open to trucks later.	Use accelerated mixtures only when necessary. Opening strengths are those typically specified.
Pedestrian Access in Intersections/Urban Areas	Channel pedestrian movements around construction zone.	In areas where heavy pedestrian traffic must be accommodated, detouring the pedestrian path may be necessary.
Traffic Control Devices	Traffic can be accommodated during construction. Fit traffic control to user needs and follow the MUTCD (FHWA 2003b).	Too many times concrete overlays are eliminated as rehabilitation options when the project is to be built under traffic. The limitation of clearance requirements for paver tracks and stringline are no longer valid since many options are now available.
Lighting	Lighting allows night work. Lighting must be movable with construction.	Number of lights and control of light patterns within work zone must be considered.

Table 24. Considerations for Concrete Overlay Construction under Traffic, continued

Factors to Consider	Objectives / Expectations	Considerations / Limitations
Nighttime Construction	Nighttime construction is increasing. It provides an off-peak construction period that lessens disruption to the traffic.	Nighttime visual limits must be utilized. They include shorter spacing of channelizing devices, longer transitions, changing colors nearing off-ramps, widening pavement markings, using glare screens, using more truck-mounted attenuators, using real-time information on signs and changeable message signs, and covering signs when work is not being done.
Lane Capacity	Examine lane capacity of construction zone speed and not design speed of roadway.	Must deal with existing traffic flows in a safe manner for the driver and construction worker.
Large Trucks	Limited data show that tractor-trailer crash involvement in work zones is higher than the national average for these vehicles, particularly on the interstate system.	Special attention should be given to accommodate tractor-trailer combinations, both in work zones and their transitions, especially where there are large truck volumes. Items to consider are lane widths in curves with runs of barrier on both sides and stopping distance where congestion is expected.
Detours	Must be conveniently located and have effective signage.	May have negative impact on users. Always minimize the out-of-distance travel where possible.
Events		
School	Coordinate schedule with bus routes and events.	The schedule may be difficult to control because of limit changes.
Commuters	Plan project to minimize disruption.	Normally limits can be relied upon.
Holiday	Normally work stops during holidays.	Holidays present an uncontrollable increase of traffic.
Visibility	Provide adequate stopping distance, which increases overall safety.	Equipment and traffic control must be considered in regard to visibility.
Construction Staging		
Staging Area	The project limits should be evaluated to determine adequate staging areas. The staging areas are necessary for ready mix truck washouts, storage of equipment and materials, construction trailers, and possibly a portable concrete mixing plant.	A dedicated ready mixture plant or mobile batch plant located near the project site will also cut down on the haul times to the site, and the quality of the mixture will be more easily controlled.
Incremental Lane Closure (Leap Frog)	Allows for continuous single lane paving in one direction, leaving opened areas for traffic recovery.	Requires multiple traffic control setups and pilot cars.
Mobilization	It is important that the project is planned to minimize staging operations. Every time a stage comes to an end, there are mobilizations necessary to regroup and prepare for the next step in the paving process.	Remobilizing of the paving crew on the project site takes time, and time not paving increases costs. A preferred approach is to minimize the staging operations and mobilizations.
Work Production	To keep paving crews busy and provide cost-effective work, it is important to keep construction crews effectively utilized in construction projects involving overlays. That requires the crews to utilize effective work schedules that provide continuous and uninterrupted results.	Length based on curing time and production rates and acceptable traffic delays when under traffic.
Number and Type of Lane Closure	Traffic control must meet acceptable standards. Methods and materials used must meet project restriction.	Number and type of closures will depend on traffic demands, lane capacity, adjacent access requirements, and number of available traffic lanes.
Paver Encroachment	All encroachment restrictions can be met.	Normal stringline and track paver widths per side is typically 4 ft (1.2 m). One foot incremental encroachment reduction (up to 3 ft [0.9 m] reduction total) is common through typical machine adjustment. These do not require specialized pavers, but may require adjustment or modifications to an existing paver. Stringless paving minimizes this problem.
Construction Under Traffic Versus Lane Closure	A thorough analysis comparing road user costs and construction durations and construction costs should be performed for design alternatives (full closure vs. maintaining traffic through the construction zone).	Additional construction cost and delays to users when construction is under traffic must be compared to travel delay and out-of-distance travel for detours.

Table 24. Considerations for Concrete Overlay Construction under Traffic, continued

Factors to Consider	Objectives / Expectations	Considerations / Limitations
Overlay Construction		
Thickness of Overlay	Thinner overlays cure quicker, causing stresses to form earlier. Therefore, early sawing is important.	Thin overlays are subject to higher risk of cracking (shrinkage, curling, and warping stresses).
Weather		
Cold weather (below 40°F [4.4°C])	Consider covering pavement to help achieve opening strength.	Develop a QC plan that addresses cold weather placement issues. Specifically, insulation methods to assure that the pavement will not freeze until it reaches opening strength.
Normal weather 40°F to 85°F (4.4°C to 29°C)	Overlays have fast strength gain and high production rates with reduced early-age cracking potential.	There should only be project restrictions and not normal material or equipment limits.
Hot weather > 85°F (29°C)	Faster strength gain exists during hot weather.	There is a higher risk of surface cracking during hot weather. Proper curing is important. Also, bottom up cracking needs to be considered when the underlying pavement is too hot.
Construction Equipment	One of the most important aspects of accelerated construction that is often overlooked is the availability and performance of the equipment on the site. All equipment should be in working condition and properly maintained. The contractor should present a back up plan in the event of equipment failure during construction. Proper parts, hydraulic fluids, oil, and fuel should be readily available. Concrete saws should be abundant and readily available on the job site.	In the event of failure to the concrete paver, a plan should be available to continue operations. The plan could be simple, such as keeping a mechanic on call, or it may be more complex, such as having a backup paver in the vicinity. A staging plan should be part of the back up plan to properly rout traffic in the event of scheduling disruptions. If the pavement is to be open in a matter of hours after paving, the critical stage is often the sawing. It is important to have the adequate manpower and saws on the job site when constructing a concrete overlay on an accelerated schedule.
Curing	Curing is arguably more critical for overlays than for most other paving. The relatively thin nature of concrete overlays increases their surface area with respect to the volume of concrete. The result is more susceptibility to excess moisture loss and the distresses that can result from this. To avoid problems including plastic shrinkage cracking, full-depth shrinkage cracking, wide joints, and surface distresses, a rapid and effective curing program should be adopted that includes using twice the recommended compound rate for thin overlays.	While cost should be a consideration, the incremental quality improvements, such as high production curing from an effective curing program, will often far outweigh the additional cost.
Special curing	For overlays that require a very short opening to traffic and are relatively short in length, special curing in addition to curing compound is used. It normally consist of insulating blankets that provide a uniform temperature environment for the concrete.	Special curing is normally not required in summer months for accelerated construction, but it does have an effect on strength gain when air temperatures are less than 65°F (19°C), and it has a pronounced effect when temperatures are less than 55°F (13°C) in colder months.
Sawing	Sawing concrete overlays is also typically a more critical operation as compared to more conventional concrete paving. The thin section will often gain stresses rapidly, and thus require accelerated sawing. Sometimes the need for accelerated sawing is underestimated and the sawing operations fall too far behind the paver. To respond to this, the contractor should be prepared with the proper type and number of saws. In the case of sawing, redundancy in equipment is also important.	The timing of the saw cutting should be done to balance the potential for uncontrolled cracking with the potential for excessive joint spalling during sawing. Bonded concrete overlays over concrete require the most effective sawing operations to prevent overlay failures. Not only does the transverse joint require full depth saw cut plus 0.50 in. (13 mm) over the existing joint, the width of the cut should not be less than the existing transverse crack below the existing saw cut. This allows the two monolithic pavements (overlay and existing pavement) to contract the same way. For overlays on asphalt, particularly when there is wheel rutting in the asphalt, the depth of the saw should be increased to account for the extra depth in the wheel rut areas.
Fillets	Provide fillets for a level of safety precaution at dropoffs.	Placement of form fillets may require sawing.

Table 24. Considerations for Concrete Overlay Construction under Traffic, continued

Factors to Consider	Objectives / Expectations	Considerations / Limitations
Opening Pavement Considerations		
Public Relations	Where construction will affect adjacent homeowners and businesses along with the traveling public, an effective public relations campaign should be implemented. Flyers, media coverage, and public meetings regarding the project schedule and the reason for the schedule timeline need to be developed and implemented. Preconstruction meetings between the government and the citizens, with the contractor in attendance, help keep the public well informed and allow the contractor to understand any concerns.	Construction needs to follow the schedule and, during construction, signing to business access is very important, along with daily communication between the contractor and the impacted business. Informed local drivers can avoid the area when possible, thus reducing delays.
Schedule	The project schedule must be reachable and realistic. The schedule affects public acceptance, contractor's methods, payment and incentives, quality of work, and safety. Most accelerated construction projects are moving more to calendar days and days when work is not usually done in order to address critical completion dates where a large volume of traffic is affected. It also allows for the counting of weekends when necessary and eliminates working day issues of whether a contractor could or could not work.	Proper equipment and staffing, mixture, construction methods, curing, and sawing are all considerations. There is a need to understand the impact of traffic controls and openings, staging, material requirements, and isolated restricted spot locations on the construction schedule.
Maturity Method	Utilizing maturity testing for concrete paving provides a reliable technique for estimating in-place strength and thus the time of opening. Maturity testing provides a reliable technique for continuous monitoring of concrete strength gain. Most importantly, maturity testing enables any pavement to be opened to traffic as soon as it meets strength criteria. Concrete maturity concepts are being applied by 32 states.	Development of a maturity curve is an important element of maturity testing. As construction proceeds on a project, validation of the maturity curve may be necessary when changes occur in mixture constituents, material sources, mixture operations, and the water-cementitious materials ratios. Also some states set an automatic validation criterion based on a time period. Most states that use a maturity curve have validation criteria established which allows some flexibility in mixture changes without the development of a new maturity curve.
Opening Strength	See "Early Opening of Overlays to Traffic" section.	See "Early Opening of Overlays to Traffic" section..

APPENDIX F

STRINGLESS PAVING OPERATION

In the stringline operation, the paving equipment gets horizontal and vertical guidance through the locations and elevations of the stringline relative to a set centerline profile and pavement cross section. The stringless operation compares the elevation and position of the paving machine to a predetermined computer surface model or electronic set of cross sections of the required final pavement surface at any given time and location. The paving machine computer processes its exact X, Y, and Z location and position in relation to a computer model of the new pavement surface. The onboard computer first adjusts the alignment of the slipform paver relative to the existing roadway. It then adjusts the elevation of the machine on each of the four corners of the paver to achieve the correct pavement thickness, crossfall, and mainfall; see Figure 133. The stringless system directs the paver to make necessary changes to meet these values.

Just as with stringline paving, the field staff can make adjustments in the operation of the stringless system to improve the final surface profile or adjust for local situations. Stringlines can be adjusted up or down or

moved horizontally by the paving crew to meet local needs. They can also manually adjust the paving surface up or down on the paving machine. The paving hubs or reference points at predetermined distances (usually 12 to 25 feet) along the route become the reference for any disputes over the final product. Changes in stringless paver operations are all made from a touchscreen on the paver to raise or lower any of the four corners of the machine. Reference points at 250–500 feet to 2 miles (dependent on the system) along the route become the reference for the stringless operation.

Base and concrete surface elevation checks for the stringline operations are usually done through the use of a string being pulled between the two stringlines and vertical measurements being obtained between the string and the surface in question. In the case of the stringless system, a rover unit (GPS locator and hand-held computer) is used to check any location on any surface within the model area, in front of or behind the paving equipment. The rover must be in contact with a total station, laser, or GPS positioning unit.

Horizontal and Vertical Control Requirements and System Limitations

Tight vertical and horizontal control is essential in either stringline or stringless paving. The vertical control must be within 0.03-foot accuracy to provide the acceptable ride for incentive pay in most states. Minimum vertical curve lengths of 150 feet and desirable curve lengths of greater than 350 feet are suggested to meet profile criteria.

Coordination of sensor sensitivity in the paver hydraulic system and in the response of the paver to an electrical impulse both must be coordinated to achieve the desired profile results. Retrofits of the hydraulic systems on older slipform pavers may be necessary to provide smooth vertical movements in the paving operation.

In the case of any system that relies on GPS horizontal control, it is important to have constant communication between the ground receivers and the satellites. Loss of signal may stop the machine or put it into a constant direction and profile slope to allow it to pass under a bridge, tree, or other item blocking the satellite reception.

The operation of total stations can be affected by the following environmental conditions:

- Heavy surface wind vibration of the instrument
- Spring and fall low-sun-level interference with line of sight
- Paver exhaust system location relative to prisms
- Location of nighttime lighting systems relative to the paver and instrument
- Fog limiting or halting paving until clear communication between prisms and instrument is established

Each of the systems has the ability to be used on each of the items in the paving train from the bulldozer, grader, and trimmer on the construction of the subgrade and base to the spreader/belt placer and slipform paver. The number of control units required varies with the length of this portion of the paving train. Texture/cure equipment behind the paver is usually controlled mechanically with sensors on the side and top of the finished product.

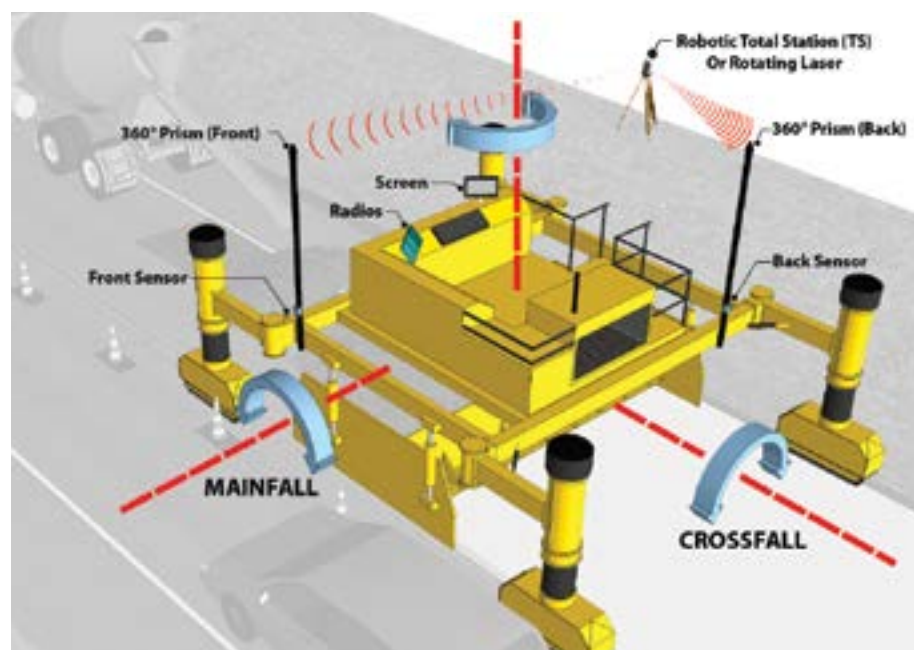

Figure 133. Paving machine control

Three-step Process for Stringless Paving

Utilizing stringless paving technology involves a three-step process. The first step is collecting survey data of the existing surface to develop and build a roadway surface map; see Figure 134. Step two is to design the roadway and create the proposed 3-D computer model using the existing surface and proposed profile and cross sections. The third and final step is to construct the proposed pavement by transferring the computer model to the paving machine and utilizing a noncontact X,Y,Z guidance system.

In order to map the existing roadway surface, an all-terrain vehicle (ATV) can be used, equipped with a laser profiler (Z coordinates) or GPS receiver and GPS (X,Y coordinates);

see Figure 135. The utility vehicle is driven along the pavement at 5 to 15 mph, recording the existing pavement profile at 25- to 50-foot intervals along the pavement edges, wheel paths, lane quarter points, and centerline. It needs to be noted that GPS accuracy is good vertically to only 1 inch, so to obtain the proper accuracy in the Z coordinate, the ATV had to be augmented with a laser system or software correction. An alternate to the ATV is to survey the existing pavement with a total station.

The data collected are used to produce a 3-D plot of the pavement surface utilizing readily available CADD (computer-aided design

and drafting) software. Data is streamed from both units to a central computer for storage.

The ground reference system should contain reference points with known X,Y,Z values, spaced on alternating sides or one side of the roadway depending on the system used. The Z value should be obtained through electronic three-wire leveling just in advance of the construction to verify the overlay design assumptions and assure that the final product will meet the designer and contractor requirements. The data management method involves translating data to a project coordinate system.

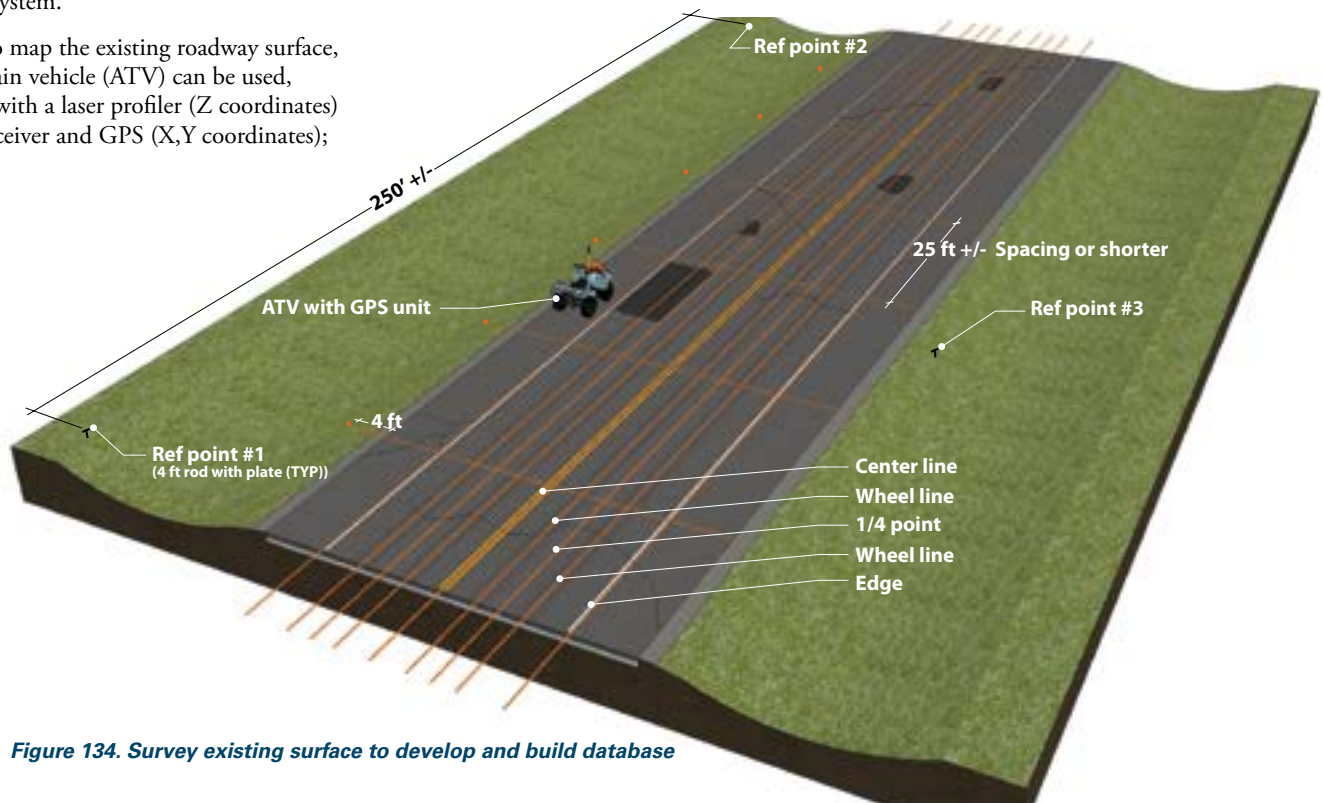

Figure 134. Survey existing surface to develop and build database



Figure 135. ATV with GPS and laser profile

Existing Stringless Control Systems

Currently there are three systems in use to partially or fully utilize stringless paving technology. Field training and support are required for each of the systems and should be requested in any agreement with the contractor.

System No. 1

The first such system, shown in Figures 136–138, utilizes surveying total stations, lasers, and radio communications to provide machine control. Two total stations are shown in Figure 136. Prisms on the two masts shown on the paver in Figure 137 form the receiving ends of transmissions from the two total stations on the backslope of the roadway in

the same figure. The screen in Figure 138 represents the controls the contractor has to monitor the operation or make manual changes. It relies on an initial reference system established by the highway agency at 1,000-foot intervals with X,Y,Z coordinates; see Figure 137. X and Y may be established with GPS survey equipment, but Z must be established through the use of digital or three-wire level circuit operations to provide an accuracy of 0.01 to 0.03 foot. Contractor surveys are required to provide intermediate control points, map the existing pavement surface, establish a final surface with profiles of the centerline and pavement edges, and calculate concrete quantities and pavement depths to meet highway owner requirements.

The paving equipment in this operation is controlled by two total stations that may be set on one or opposite sides of the road to

communicate with the paving train equipment. Each total station locates itself through sighting three known and previously established reference points (approximately 250 feet apart) inside the primary control or 1,000 foot points of the highway department. Lasers on the total stations locate a prism on the paving equipment, and a specific radio frequency for each total station communicates the relative position of each to the computer model in a computer on the paving machine. The paver onboard computer contains the pavement surface model and instructs the paving device on changes in direction and elevation for the paver. Similar equipment can be installed on a spreader/belt placer for horizontal control only or in conjunction with vertical control. Other paving train equipment such as the cure/texture carts are usually controlled by mechanical means.

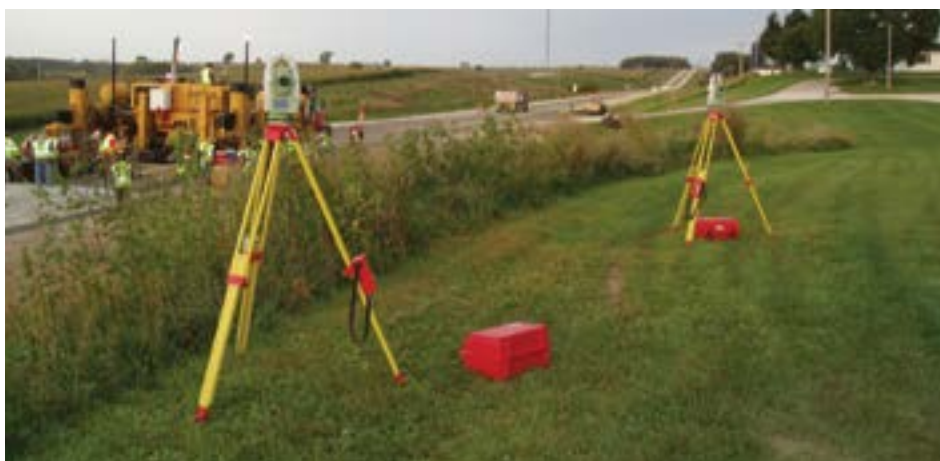

Figure 136. Total robotic station



Figure 138. Computer controls on paving machine

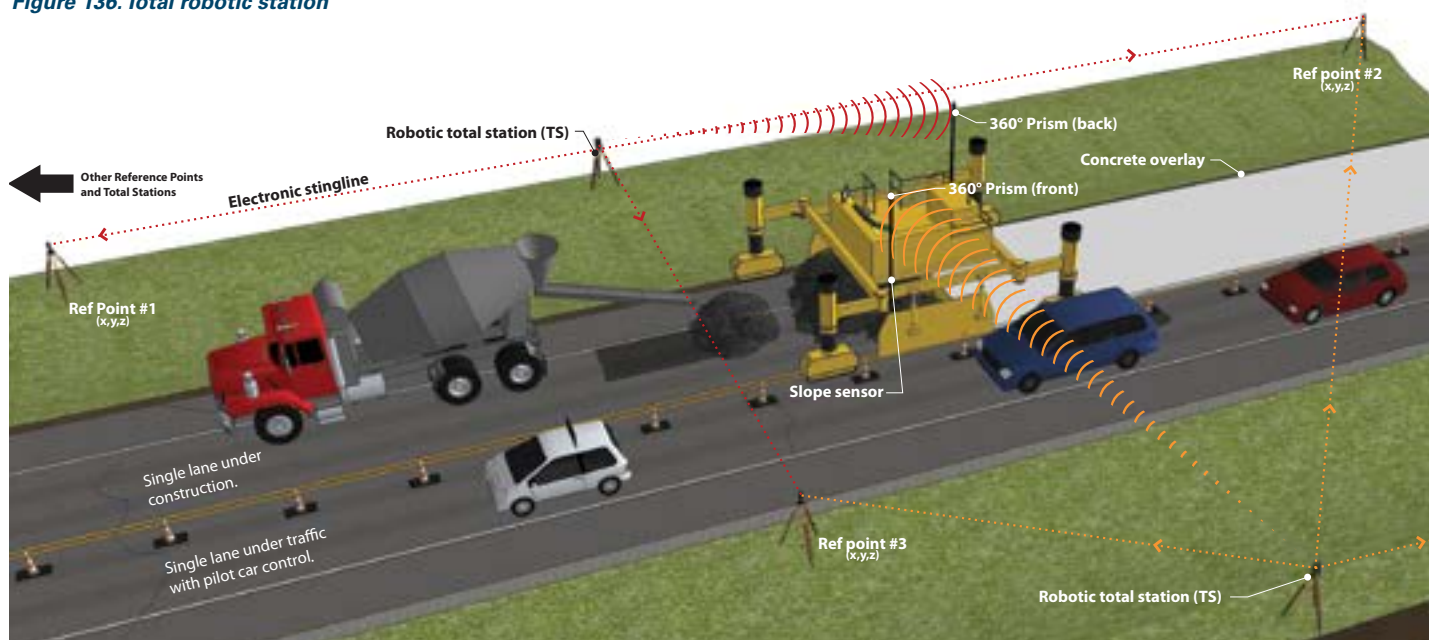

Figure 137. System 1—Stringless paving operation using total stations and reference points

System No. 2

A second stringless system, shown in Figures 139–141, utilizes GPS and laser communications to achieve horizontal and vertical guidance of the paving equipment. It relies on an initial reference system inside the primary control or 1,000 foot points of the highway department with X,Y,Z coordinates. Coordinates X and Y may be established with GPS survey equipment, but Z must be established through the use of digital or three-wire level circuit operations to provide an accuracy of 0.01 to 0.03 foot. Contractor or owner surveys are required to map the existing pavement surface, establish a final surface with profiles of the centerline and pavement edges, and calculate concrete quantities and pavement depths to meet highway owner requirements.



Figure 139. Rotating laser over reference points



Figure 140. System 2 paving machine

The paving equipment in this operation is controlled by a rotating laser unit that may be set on either side of the road to communicate with the paving train equipment; see Figure 139. The equipment locates itself over one known and previously established reference point (approximately 500–600 feet apart) inside the primary control or 1,000 foot points of the highway department. Elevation of the laser (Z coordinates) is established through the use of a vertical pole, of set vertical length, under the laser and over the point. The laser is self-leveling and legs are adjusted vertically to allow the tip of the vertical pole to touch the point and the laser frame. The rotating laser emits a 10-degree vertical band to the units on the paver.

Paver receivers consist of two devices as shown on the paver masts in Figure 141. The top part of the mast is a GPS receiver (X,Y coordinates) that is used to communicate horizontal guidance information to the paver onboard computer and surface model. Below the GPS receiver is a 1 mm correction receiver that relates paver and reference point locations to the computer. The paver onboard computer contains the pavement surface model and instructs the paving device on changes in direction and elevation for the paver; see Figure 141. The same rotating laser can be used to guide the spreader/belt placer with only the GPS receiver and an onboard computer with surface program installed. Other paving train equipment such as the cure/texture carts are usually controlled by mechanical means.

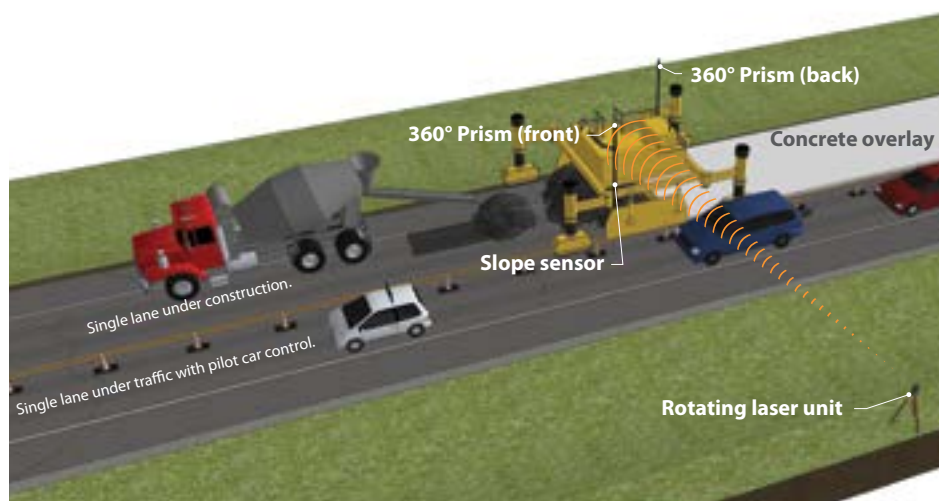

Figure 141. System 2—Stringless paving operation using GPS, a rotating laser, and reference points

System No. 3

The third system, shown in Figures 142–144, is a new emergence of stringless paving technology and is a blend of the elements currently being used in the first two systems and the additions of items that can reduce the time of survey prior to and during paving. It is based on the use of GPS to guide the paving train and a computer program that can react quickly enough to give real-time corrections from the elevation portion of the GPS signal to the slipform paver or belt placer, in order to provide accurate elevation data to 0.01 foot for development of profile information necessary to meet highway agency needs. The GPS system requires a base station on site with a 2+ mile radius of influence and known X,Y,Z coordinates at the beginning, ending, and third points of a typical 5-mile project. The base station location can also be tied to other known survey points outside the pavement corridor. The slipform paver or spreader is equipped with one GPS mast and two-way slope sensors to adjust the paver movement. The operator can manually observe the action of the paver from an onboard computer screen and make manual adjustments.

One of the advantages of this system is the use of the four-wheel ATV equipped with a GPS base station receiver and software

that contains the design centerline profile and cross section; see Figure 142. By driving the ATV along a known and set location on the roadway (5–15 mph), the GPS on the ATV determines the existing surface elevations. Using the vehicle's software, the surface elevations are then compared to the design profile at given points to create a 3-D model. This model is then provided to the stringless paver. This particular view of the vehicle contains both the data collection equipment on the machine and the separate GPS base station that acts as the reference point for data collection and communication with the paving train. The information from the existing surface profile, a design overlay centerline profile, and a typical pavement surface cross section is fed to a program that cuts cross sections at specified stations along the route.

The output is a set of pavement surface cross sections by station rather than a surface model as in the first two systems. It interpolates changes between stations as the other systems do between points in the model. The software is built on the concepts used by the early geodimeters and total stations, but it relies heavily on the manipulation of the GPS signal through mathematical models to gain the vertical accuracy of 0.01 foot. The control equipment on the paver shown (Figure 143) is similar to that used on the other systems. Keep in mind this system does not require any laser or radio communications between reference points and the paving equipment—only GPS communications.



Figure 142. GPS base station mobile or fixed



Figure 143. GPS paver control system

Stringless System Equipment Selection Criteria

The decision regarding the type of stringless paving system to be used should be made by the contractor. This decision should be based on several factors, such as the following:

- Site control provided by the owner. The highway agency may not have the resources or desire to set paving hubs. It may request the contractor to develop the horizontal and vertical control for paving.
- Construction site accessibility. The highway agency may not allow stringlines along the centerline or outside edges because of traffic control requirements. Tight working areas can limit the access by the public and construction equipment when stringlines are used.
- Accuracy and repeatability specification on equipment. The contractor must weigh the ability of the stringless system to meet the agency profile, accuracy, and repeatability specifications for the quality product the agency requires.

- Agency goals in profile and concrete yield. Can the system under consideration provide the agency and contractor with profiles that meet or exceed agency goals and provide accurate information on yield of the concrete?
- Contractor options to meet owner goals. Can the system provide information for machine control that allows for staged construction of pavement sections and meet the overall goals of the finished product in terms of construction and profile?
- Research, test, and demonstrate performance. The contractor should test the equipment on the paving train for some 500 to 1,000 feet or more without the inclusion of concrete. Paving hubs and stringline should also be in place to assure all parties that the system is working properly.
- Level of training and support available. The contractor should understand the amount of training required to operate the system and the amount that will be given prior to paving.

The contractor should retain access to a ready response system during the paving season that minimizes work stoppage due to an unforeseen system problem.

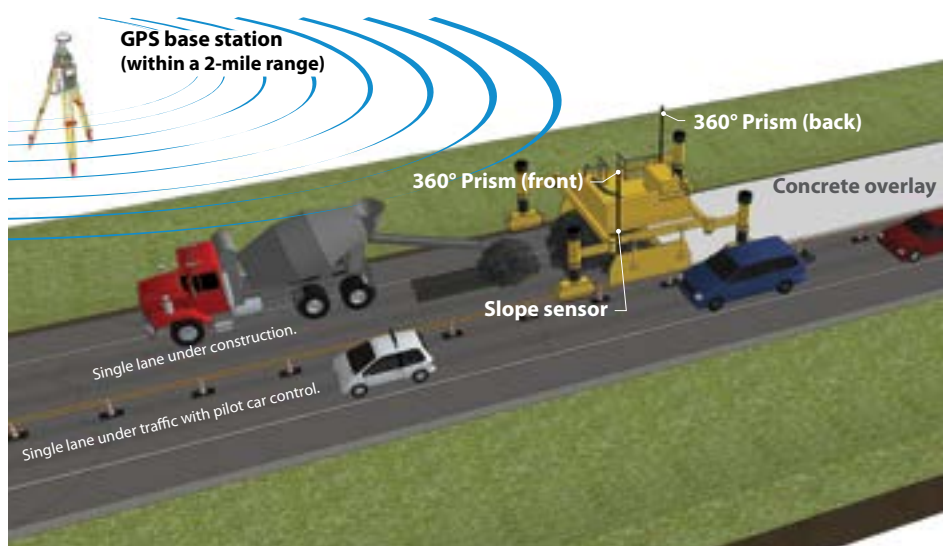

Figure 144. System 3—Stringless paving operation using GPS

APPENDIX G.

CONSIDERATIONS FOR DEVELOPING PROJECT AND SUPPLEMENTAL SPECIFICATIONS

Every jurisdiction has its own project development process and concrete pavement specifications. The following guidelines can be used in overlay project development and in developing supplemental specifications or special provisions. They apply to bonded and unbonded concrete overlay projects on existing concrete, asphalt, and composite pavements.

The guidelines are specific only to concrete overlay projects and do not represent every item that needs to be considered in a concrete paving project.

General

Contractor Submittal Considerations

- Maturity method for strength determination prior to opening to traffic.
- Paving mixture design for each source of aggregate to be used for review and approval by the engineer.
- Provide material certifications to the engineer.
- Where required, submit a plan for construction sequence and schedule prior to commencing construction. If the plans show a specific sequence/schedule, the contractor may need to verify compliance with the schedule or submit an alternate plan to the engineer for approval. A detailed staging and sequencing plan is recommended for concrete overlay projects when using an expedited construction process and schedule of opening.

Scheduling and Conflicts

- Construction sequence: A preconstruction meeting is recommended to discuss critical items such as staging, opening strengths, time of placement, and overall schedule.
- Typically, a concrete overlay schedule is much shorter than a standard concrete paving project.
- Conflict avoidance: Expose possible conflicts in advance of construction. Verify

elevations and locations of each and verify clearance for proposed construction.

- Complete elements of the work that can affect line and grade in advance of construction unless noted on plans.
- Traffic control plan: The contractor should develop a traffic control plan where required based on the MUTCD (FHWA 2003b) and approved by the engineer.

Limitations of Operations

In addition to the limitations of operations for the placement of standard concrete pavement, the following limitations for concrete overlays apply:

- At air temperatures below 55°F (13°C), the opening of the pavement should be established using in-place strength measurement devices, such as the maturity method (ASTM C-1074). In order to place concrete in cold weather, air temperature requirements for the jurisdiction should apply.
- The engineer may impose a restriction on edge loading of construction equipment on the finished slab until opening strength is reached.
- Bonded concrete overlays should be placed according to the local jurisdiction's schedule, based on seasonal temperatures.
- Unbonded overlays should not be placed when the asphalt or concrete pavement surface temperature exceeds the maximum temperature allowed by the engineer. Typically, this temperature is around 120°F (49°C). Water may be added to cool the pavement ahead of the paver. The surface should be dry and free of standing water prior to paving.

Method of Measurement and Basis of Payment

The quantity of the various items of work involved in the construction of concrete overlay will be measured by the engineer in accordance with the following provisions:

- Surface preparation may include milling, air, water, and sand- or shotblasting; these should be measured and paid in square

yards. Sweeping and cleaning with compressed air is a surface preparation task but is most often incidental to paving.

- Concrete overlay, furnish only: The quantity of concrete furnished will be measured in cubic yards. This quantity should include concrete placed in widening sections and partial depth patches. The contractor can be paid the contract unit price per cubic yards. This payment should be full compensation for furnishing all raw materials, and for proportioning, mixing, and delivery of concrete to the paving machine.
- Concrete overlay, placement only: The quantity of concrete overlay, placement only, should be measured and paid for in square yards. This will be the quantity shown in the contract documents. The area of concrete overlay placement can be determined from the length and pavement width, including widening sections. Payment should be full compensation for labor and equipment necessary to place, finish, texture, protect and cure the pavement, including sawing and sealing (if required) joints, furnishing, and installing reinforcement (if required).
- Separation layer: Hot mix asphalt or other approved separation layer material should be measured and paid by area or weight.
- If the contract documents require accelerating curing, such as wet or blanket curing, the curing area should be measured and the contractor should be paid per square yard.

Materials

- The CTE of the bonded overlays over concrete need to be similar to that of the existing concrete pavement. This is typically accomplished by using similar aggregates in the concrete mixture. If it is not possible, a coarse aggregate should be used in the overlay that has a lower CTE than in the existing pavement.
- The largest particle size of the coarse aggregate should be less than or equal to one-third of the overlay thickness.
- Refer to contract requirements for concrete mixture parameters.

Separation Layer for Unbonded Overlays

- If asphalt is used as the separation layer material, it should be designed with the intention of preventing asphalt stripping from the build up of pore pressure from heavy traffic. Special consideration should be given to pavements where high speeds and heavy trucks are expected. These variables are known to contribute to stripping.
- Fabric: Technology is evolving rapidly on the use of geotextile fabric for the separation layer. Care should be exercised in selecting geotextile fabric, however, because not all products perform equally well for this application.

Construction

Preoverlay Repairs

- Preoverlay repairs include: slab stabilization and slab jacking, partial depth repairs, full-depth repairs, retrofitted edge drains, load transfer restoration, and milling. If milling is part of the repairs, it should be completed prior to other repairs.
- Materials removed in the preparation operation may be temporarily placed in the shoulder area unless otherwise specified in the contract documents. The removal of materials must take place prior to the removal of approved construction signage.
- Surface preparation equipment used should be subject to approval of the engineer. Milling, air, water, sandblasting, and shotblasting equipment should be power operated and capable of preparing and cleaning of the existing surface in accordance with the contract documents.

Bonded Concrete Overlays Over Concrete

- The surface of the existing pavement should be prepared by shotblasting, sandblasting and/or milling. Milling, if used, should be followed by shotblasting or high pressure water blasting to remove concrete damaged during milling (evidenced by microcracking).
- Preparation should be adequate to remove all dirt, oil, and other foreign materials, as well as any laitance or loose material from the surface and edges against which new concrete is to be placed.
- Airblast surface to remove loose debris and prevent resettlement of debris into cleaned area. The surface should be free of oil or other automobile fluids. The pavement surface should not be moist or damp or

have standing water prior to placement of the overlay.

Bonded Concrete Overlays Over Asphalt

- A guideline to determine whether milling is required is if asphalt surface distortions are 2 in. (5.08 cm) or greater. If milling is specified, it is important that there is at least 3 to 4 in. (7.62 to 10.16 cm) of asphalt remaining prior to the overlay. Milling should remove the asphalt to the nearest tack line.
- After milling, the surface should be inspected for further preoverlay repairs. The milling operation may expose wide thermal cracks. If the cracks are wider than the maximum overlay aggregate size, they may be filled with fly ash slurry, sand, or other appropriate material.
- Following any milling, partial or full depth repairs should be completed with concrete to ensure bonding with the overlay.
- All concrete patches plus the overlay should be isolated from the rest of the overlay using normal joint patterns.

Unbonded Overlays Over Concrete

- For uniform support of the overlay, all partial and full-depth repairs should be completed with concrete.
- The concrete surface should be cleaned prior to the placement of the separation layer. If a leveling course is required, it should be completed with the concrete overlay and not with the asphalt separation layer.

Unbonded Concrete Overlays Over Asphalt

All partial and full-depth patching should be completed with asphalt. Existing concrete patches in the existing asphalt pavement should be isolated to prevent bonding to the concrete overlay. A debonding agent, fabric, or other bond-breaking material should be applied to the patch before the overlay is placed.

Surface Cleaning

Bonded Concrete Overlays Over Concrete or Asphalt

- The surface of the existing pavement should be cleaned by sweeping and followed by compressed air in front of the paver. Paving should commence soon after cleaning to minimize contamination.
- Pressure washing should only be considered when surface contaminants are hard

to remove or when mud or other debris is tracked on the surface. If pressure washed, no standing water should be allowed prior to paving. Paving should commence soon after cleaning to minimize contamination.

Unbonded Concrete Overlays Over Concrete or Asphalt

Surface cleaning is provided by sweeping of the existing asphalt surface with a mechanical sweeper or air blower. Paving should commence soon after cleaning to minimize contamination.

Concrete Placement

Grade Control

- The engineer will review and approve the control system. Information detailing the pavement thickness at the various survey points and material quantities should also be provided.
- Concrete paver should place in single lane width or be capable of adjusting the crown at each plan lane line when placing multiple lanes.
- When appropriate, grade control for the paving operation should be referenced off the milled surface, unless the milling machine is controlled by a previously established paver control line.

Overlay Placement

- Surface watering may be allowed by the engineer to help cool the pavement in extremely warm conditions and when the existing pavement surface condition is at or exceeds 120°F (48.89°C). The pavement surface should not be moist or wet prior to placement of the overlay.
- Conventional concrete paving procedures should be followed for placing, spreading, consolidating, and finishing the unbonded overlay when required. When dowels are specified, anchoring dowel baskets to the underlying pavement must be done according to the jurisdictions requirements. Alternatively, paving machines equipped with dowel bar inserters can be used.
- A quality control plan should dictate the time of placement with consideration given to air and pavement temperatures. For bonded overlays on concrete, it is not desirable to have the overlay pavement contracting, due to shrinkage, at the same time as the existing underlying concrete is expanding due to the heat of the day. The best time to place a bonded overlay over concrete is when the temperature differential between the existing pavement and new overlay is minimal.

Liquid Membrane Curing

- Apply curing compound immediately after surface moisture has disappeared but typically no later than 30 minutes after finishing/texturing. Apply liquid curing compound in a fine spray to form a continuous, uniform film on the horizontal surface and vertical edges of pavement, curbs, and back of curbs.
- Use a white pigment liquid curing compound for concrete.
- For overlays with a thickness of 6 in. (150 mm) or less, apply curing compound at 2 times the manufacturer's recommended application rate for a standard concrete pavement. Do not dilute the compound.
- For overlays with a thickness greater than 6 in. (150 mm), curing compound should be applied at 1.5 times the manufacturer's recommended rate for a standard concrete pavement.
- When white pigment curing compound is employed correctly, the surface of the concrete pavement should be solid white with no visible grey.
- If forms are used, apply to pavement edges and back of curbs within 30 minutes after forms are removed.
- Protect concrete pavement during cold weather for at least 5 days, or protect for a minimum of 24 hours and until flexural strength of 340 psi (2.3 MPa) is achieved for unbonded concrete overlays, 420 to 480 psi (2.9 to 3.3 MPa) for bonded concrete overlays over asphalt, and 540 psi (3.7 MPa) for bonded concrete overlays over concrete.

Joint Sawing

General

- The contractor should provide a joint sawing plan that demonstrates how all saw cuts will be accomplished within a shortened sawing window. Details should include the number of saws and anticipated sawing production rates, as well as estimated starting and finishing times. All sawing must be completed within the first one-half of the sawing window.

The contractor should exercise care in placing, consolidating, and finishing the concrete at and around all joints.

- Wet sawing should be used when required by the contract documents for dust control.

Joint Width

- All conventional sawing widths are normally 0.19 in. (4.8 mm) +/- 0.06 in. (1.5 mm).
- All early entry sawing are normally 0.13 in. (3.3 mm) +/- 0.06 in. (1.5 mm) in width and a minimum T/4 inches in depth.

Joint Seal

- Joint sealing should follow the jurisdictional requirements. When narrow (.13 in. [3.3 mm]) saw cuts are used and sealing is required, follow jurisdictional requirements for low modulus hot-pour sealant.

Timing

- Timely sawing is necessary to prevent random cracking due to shrinkage. This is particularly important for overlays less than 6 in. (150 mm).

Bonded Overlays Over Concrete

- Prior to construction of a concrete bonded overlay, the exact location of each contraction and expansion joint in the existing pavement, including joints created by full-depth patches, should be identified and

marked on both sides of the pavement by a reliable method.

- Transverse joints should be placed in the overlay pavement directly over existing transverse joints.
- Transverse joint width must be equal to or greater than the underlying crack width at the bottom of the existing transverse joint to prevent debonding due to movement.
- Saw all transverse joints to full depth of overlay plus 0.50 in. (13 mm).
- Saw longitudinal joints to T/2.

Bonded Overlays Over Asphalt

- Saw transverse joints to a minimum depth of T/4.
- Saw longitudinal joints to a depth of T/3.
- Early entry saws may be required unless otherwise specified in contract documents.
- When 0.13 in. (3.3 mm) wide saw cuts are used and sealing is required, follow the jurisdictional requirement for low modulus hot-pour sealant.

Unbonded Overlays

- Saw transverse joints to a depth of T/4 (minimum) or T/3 (maximum). For early entry, saw depth will be 1.25 in. (31 mm) or greater.
- Saw all longitudinal joints to a depth of T/3.
- Sealing will follow jurisdictional requirements.
- For unbonded overlays over asphalt, the saw cut depth may need adjustment over rutted asphalt location in order to maintain a depth of T/4 to T/3 requirements.
- When 0.13 in. (3.3 mm) saw cuts are used and sealing is required, follow jurisdictional requirement for low modulus hot-pour sealant.

APPENDIX H.

SUGGESTED OWNER-CONTRACTOR MEETINGS TO ENSURE A QUALITY PRODUCT

The following information is provided as a starting point or guide for ensuring quality concrete performance in concrete overlays. Key elements are identified that are required of the pavement owner and contractor for each project. This is an outline for success but is not detailed in nature so that items can be added or deleted according to common practice in a given state or local government.

To accomplish the construction objectives in concrete overlay projects, it is necessary to have meetings during the design (prebid) and construction (prepour/preconstruction) period between the contracting agency and the contractor(s) to work out the details. The purpose of the prebid, prepour, and preconstruction conferences and the key elements (checklists) of each are shown below.

Prebid Meeting Check List

Prebid meetings provide an opportunity for the owner to review project requirements and receive input from contractors who may have an interest in bidding for the project. Although prebid meetings tend to be primarily a review of administrative and contractual matters, it is important to use them to highlight modifications implemented in the plans and specifications.

The prebid meeting gives the contracting agency an opportunity to identify new and different items in the areas of specifications, materials, and construction processes that are expected in the construction project. It is also a good time to receive input from the contractors on important design and construction items such as jointing, surface preparation of the existing pavement, paving exceptions, schedules, and staging. It is also an opportunity to discuss the intent of the work changes. Critical material supply/availability issues and specific acceptance testing requirements also need to be addressed.

Minutes of the meeting should be distributed to all potential bidders (those who have requested bid documents) whether they are in attendance or not. Paving-related items for discussion are listed below.

Prebid Meeting

- I. **Overlay Project Items of Special Attention**
 1. Construction differences between conventional paving and overlays
 2. Phasing and staging plan
 3. Scheduling criteria, including which areas are accessible, restrictions on site access, and working hours
 4. Scheduling milestones with incentives/disincentives
 5. Allowable mixes and special conditions such as fibers
 6. Strength requirements and strength-testing measurement methods
 7. Traffic control, clearances, staging requirements, and edge-drop restrictions
 8. Expected and unexpected delay resolution
 9. Plant and staging area locations
 10. Paving sequence, paver clearance, and pavement dropoff limitations
 11. Haul road locations
 12. QA acceptance testing and QC requirements
 13. Issuance of design and specification changes
 14. Pre-overlay repairs and surface preparation
 15. Special conditions such as tie bar locations, widening details, etc.
 16. Saw cut depths as well as timing and importance of early joint development
 17. Curing, particularly curing for thin pavement sections
 18. Incentives and disincentives applied to overlay construction
 19. Pavement ride requirements on the finished product
 20. Importance of reducing the length of time for job completion

II. Alternative Bid Provisions

1. Materials selection
2. Management method (conventional, A+B, etc.)

III. Discussion of Questions from the Prospective Contractors

IV. Issuance of Addenda to Clarify Questions Raised at the Prebid Conference

1. Minutes of the meeting to all who attended and those who call for plans on the project

Prepour/Preconstruction Review Checklist

Prepour or preconstruction meetings can be very productive when the contractor is tasked with addressing the pertinent items. They may be conducted as one combined meeting or two separate meetings, depending on the level of detail the contractor is able to provide at the preconstruction meeting. The contractor should be able to present the plan for addressing each of the items on the review checklist for review and comment at this meeting. Forcing the contractor to think about the project and build it on paper before the prework meeting will pay big dividends. The overlay team should be involved in the prework so they can receive guidance and answers to unresolved issues and/or identify potential problems with the contractor's approach.

I. General Items

1. Identify the chain of command in the decision-making process
2. Identify roles and responsibilities of key staff for all involved parties
3. Review of all design and construction changes issued since bid
4. Certification of materials sources
5. Mix design submittals
6. QMP/QC laboratory and personnel certifications
7. Batch plant certification and mixer

efficiency tests

8. Construction schedule
9. Payment schedules
10. Subcontractor activities
11. Construction survey
12. Haul roads and access points
13. Traffic control plan for each phase of the work
14. Working days allowed and method of counting
15. Expected start date
16. Phone numbers and email addresses of key personnel such as contractor and agency representatives, traffic control manager, material suppliers, and utility location representatives
17. Liquidated damages
18. EEO/AA requirements
19. Public information notification process to be used during construction
20. Pollution control plans
21. Safety inspections
22. Change order process
23. Conduct of a half-day overlay workshop

II. Contractor Project Plan

1. Identify the chain of command in the decision-making and construction process
2. Work schedule breakdown by major task, starting date, and expected duration
3. Field lab location
4. Field office location
5. Subcontract documentation
6. Material source and quality certifications
7. Material testing lab and technician certifications
8. Submittal of concrete mix design
9. Water sources and testing
10. Traffic control plan for each phase of the work
11. Haul road and access point location and duration identification
12. Construction survey

- a. Method—contract or owner
 - b. Type and amount of available information
 - c. Stringline or stringless construction
 - d. Development of the profile grade and concrete quantity by whom and when (Is there an approval process and timeline before construction?)
 - e. Reestablishment of land corners and centerline control points
13. Public information notification process to be used during construction

III. Utility Concerns: Locations in the project limits, key personnel for location contact, and expected plans for relocation where necessary

IV. Local Jurisdiction Concerns: Coordination with local road projects or city/county special activities (e.g., festivals)

V. Concrete Placement Activities (This can be part of the preconstruction conference or a separate prepour conference.)

1. Batching activities
 - a. Identification of central mix or ready-mix supply source
 - b. Stockpile management to eliminate segregation
 - c. Batch plant certification and mixer efficiency testing
 - d. Anticipated plant production rates
 - e. Concrete haul route identification and estimated truck number needed for existing traffic along the route
 - f. Consideration of alternative mixes to meet weather changes
 - g. Aggregate stockpile moisture
 - h. Identify washout areas for trucks
2. Concrete paving (placement, finishing, texturing, and curing)
 - a. Overlay temperature planning and management (on-site weather condition monitoring and who and how it entered into the decision to pave and cover or not to pave)
 - b. Placement and filler lane scheduling
 - c. Base preparation (patching, milling, recycling)
 - d. Equipment breakdown procedures

- e. Maximum allowable concrete haul times
 - f. Placement procedures (equipment and methods)
 - g. Estimated mix temperature at the time of placement
 - h. Thickness verification during placement
 - i. Estimated time from placement to time that allows for joint sawing
 - j. Hot/cold weather specifications and precautions
 - 1) Changes in mix for weather or material changes
 - 2) Identification of method and materials to be used to protect the concrete in case of changes in weather (rain, snow, or hot/cold)
 - k. Temperature control of existing asphalt surfaces
 - l. Vibrator testing/consolidation issues
 - m. Curing and texturing equipment, rates, and construction procedures
 - n. Tie bar/dowel location, insertion, alignment, spacing, offset verification
 - o. Straight edge and edge slump tolerances
 - p. Plastic shrinkage cracking, edge slump, joint spalling, and full-depth cracking treatments
3. Joint development (longitudinal and transverse)
 - a. Review of contractor saw cutting QC plan (number, type, and method of sawing)
 - b. Consideration of employing early entry saws
 - c. Backup saw availability (number, personnel, and location to project)
 - d. Rain conditions and skip-sawing procedures
 - e. Joint reservoir size, shape, and depth-cut dimension tolerances and dimensions
 - f. Joint sealing installation and acceptance procedures
 - g. Saw-cutting sequence and acceptable degree of saw-cut raveling

- h. Joint sealant and backer-rod material certification submittals
 - i. Requirements on removal and flushing of joint-sawing residue
 - j. Joint beveling procedures (if required)
 - k. Joint sealant and concrete curing time requirements and methods
 - l. Joint sandblasting, reservoir cleanliness, and moisture condition requirements before sealing
 - m. Joint sealant surface depth tolerances, sealant pump, water truck, and saw-cutting equipment
 - n. Allowable ambient temperatures during sealing operations and compression seal reservoir requirements
 - o. Joint inspection procedures
4. QA/QC activities
- a. Delineation of owner and contractor responsibilities in testing and sampling
 - b. Review of contractor's QC plan
 - c. Aggregate durability, soundness, abrasion, and gradation test data and requirements
 - d. Reinforcing steel and dowel bar submittals
 - e. Materials sampling and testing procedures
 - f. Development and use of control charts
 - g. Concrete mixture designs and water-cementitious ratio effects on strength
 - h. Concrete sampling, fabrication, curing, and testing procedures
 - i. Sampling and pay factor computation overview
 - j. Documentation of test results and deviations
 - k. Verification of failing acceptance tests, retesting, and referee testing
 - l. Actions to be taken if specification requirements are not met
 - m. Pavement smoothness (ride) testing and timing
 - n. Treatment of premature cracking and spalling
 - o. Resolution procedures for expected and unexpected delay

APPENDIX I.

INNOVATIVE METHODS FOR ACCELERATED CONCRETE OVERLAY CONSTRUCTION

Table 25 provides a summary of innovative accelerated construction methods (adapted from Simon et al. 2003).

Table 25. Applicability, Pros, and Cons of Various Accelerated Construction Methods

Method	Applicability/Limitations	Pros(+)/Cons(-)
Formal partnering with design consultants, contractors, local authorities, and regulatory agencies	<ul style="list-style-type: none"> • This method has not been used very much with designers or other agencies. • Little training has been done and much skepticism is in place regarding this method. 	<ul style="list-style-type: none"> + Provides a faster and cheaper construction process due to reduction of conflicts, litigation, and claims (win-win situation) + Brings about continuous improvement in the quality of services and products + Utilizes resources more effectively + Implements easily because already being used on an informal basis + Improves communications - Limits competitive market strategy - Creates strong dependency on the partners
Methods for expediting utility relocation work	<ul style="list-style-type: none"> • In highway construction, the need for the relocation of utilities often arises, particularly in urban areas. • Relocation is handled primarily by utility companies. • Currently, there is little recourse that can be taken against utilities for delays. • Utilities have to pay for relocations. 	<ul style="list-style-type: none"> + Encourages project managers to develop more economical means and methods + Shortens project execution by using less formal documentation and improving communication + Reduces executive personnel + Produces more continuity during the project - Brings about need for independent engineers to check PMs' work - Encourages overcoming the "specialist mindset" of the organization
Intelligent transportation systems and work zone traffic control	<ul style="list-style-type: none"> • Applicable areas include but are not limited to traffic control, route guidance, automated highway systems, collision avoidance, en-route driver information, transportation demand management, etc. 	<ul style="list-style-type: none"> + Increases safety + Reduces congestion + Enhances mobility + Minimizes environmental impact + Increases energy efficiency + Promotes economic productivity for healthier economy - Requires additional training of employees - Includes costs to implement
Public input on phasing of construction	<ul style="list-style-type: none"> • This method is applicable on construction projects where there is a significant impact on the public. 	<ul style="list-style-type: none"> + Allows for more expeditious construction methods to be employed - Requires more public relations effort earlier
Multiple approaches to traffic control plans (TCPs)	<ul style="list-style-type: none"> • TCP solutions for small simple jobs are often apparent, but otherwise they should be thoroughly investigated earlier in the process. 	<ul style="list-style-type: none"> + Reduces both construction costs and user costs through optimal TCPs - Requires larger consultant fees for development because of more thorough TCP analysis
Descriptive catalog of construction technologies	<ul style="list-style-type: none"> • Applicability of new technologies could be widespread, but specifications may be affected. 	<ul style="list-style-type: none"> + Provides an online catalog that could easily be accessed and supported by FHWA and other states - Requires effort for maintenance and upkeep of the catalog
Contractor preparation of the TCP based on minimum requirements	<ul style="list-style-type: none"> • This approach will encourage contractor innovation but may be possible only on smaller, simpler projects. 	<ul style="list-style-type: none"> + Reduces efforts + Provides incentive for construction innovation - Increases costs - Excludes impact on local businesses - Means that contractor compliance with safety standards may be challenging

Table 25. Applicability, Pros, and Cons of Various Accelerated Construction Methods, continued

Method	Applicability/Limitations	Pros(+)/Cons(-)
Linear scheduling method (LSM) and accurate productivity to rate data and establish project target duration	<ul style="list-style-type: none"> • This method can be used for repetitive projects in which there are no strict dependencies/constraints between project activities. • Resurfacing overlays and shoulder improvement are good types of projects for the LSM. 	<ul style="list-style-type: none"> + Provides a better understanding of the project + Enables the planner to determine when and where a change in resources must take place to satisfy the goals set by the project + Helps identify existing relationships and encourages the project team to try different alternatives + Shortens schedule by overlapping activities instead of sequencing - Scheduling projects involving large cuts and fills might be more difficult to schedule with LSM
A+B contracting (costs plus time)	<ul style="list-style-type: none"> • A+B bidding can be used to motivate the contractor to minimize the delivery time for high-priority and highly trafficked roadways. • There must be a balance between the benefits of early completion and any increased cost of construction. • This approach requires incentives and disincentives to be effective. 	<ul style="list-style-type: none"> + Includes consideration of the time component of a construction contract + Includes favorable treatment of contractors with the most available resources to complete the project + Involves incentives for contractors to compress the construction schedule + Includes greater potential for early project completion - Requires that incentives and disincentives are carefully managed - Means that costs are defined whereas benefits are distributed to the public
Contractor milestone incentives	<ul style="list-style-type: none"> • Incentives must be relevant. • Goals must be reachable. • Incentives cannot be conflicting. 	<ul style="list-style-type: none"> + Encourages contractors to finish on time - Causes impacts to contractors to be highly scrutinized - Causes disagreements over compensable delays that may be problematic
Packaged multiprimes contracting	<ul style="list-style-type: none"> • This method can be used when a specific highway project is composed of several major segments or is very large. 	<ul style="list-style-type: none"> + Increases competition among construction bidders + Reduces pyramiding of costs, particularly overhead and profit + Reduces project time through overlap of design and construction or from multiple work forces + Requires more direct control by the project owner - Presents interface management challenges for the agency - Leads to physical interferences between contractors
Prequalified bidders based on past schedule performance	<ul style="list-style-type: none"> • Bidders qualify based on several key items, including specific project type experience, individual experience, past performance, capacity of the firm, and primary firm location. 	<ul style="list-style-type: none"> + Provides a shorter and easier selection process + Provides possibly better contractors - Reduces the competition - Requires that schedule performance data are well kept - Requires that agency and other noncontractual schedule impacts are recognized and equitably settled
Incentives for TCP development with a contractor who values an engineering cost-savings sharing provision	<ul style="list-style-type: none"> • To use this method, seek involvement of local municipalities in funding the incentive (e.g., 5 percent of estimated user cost savings). • This method requires close scrutiny to determine actual time savings. 	<ul style="list-style-type: none"> + Leads to innovative ideas for successful TCPs - Means that savings are difficult to estimate
Incentives for contractor work progress with a lane-rental approach	<ul style="list-style-type: none"> • Incentives must be explicitly described in the bid package. • Rental rates have to be significant and should address high-impact lanes. 	<ul style="list-style-type: none"> + Leads to innovative ideas for successful TCPs + Minimizes contractor impact on the traffic - Causes administration to be difficult
Increased amount of liquidated damages and routine enforcement	<ul style="list-style-type: none"> • Just as important as the damages happening in the contract are the claims made for damages. The time and effort involved in pursuing these claims is, however, a limitation. This should be weighed against potential benefits. • Possibly provide incentives to finish projects ahead of time. 	<ul style="list-style-type: none"> + Motivates better contractor performance - Requires rigorous documentation and quick request for information response to enforce
"No excuse" incentives	<ul style="list-style-type: none"> • These incentives preclude delay claims by contractors, give contractors incentives to finish early, and require a realistic schedule. 	<ul style="list-style-type: none"> + Results in considerable improvements in schedule performance - Transfers risk to contractor and therefore may increase costs on the average over time

Table 25. Applicability, Pros, and Cons of Various Accelerated Construction Methods, continued

Method	Applicability/Limitations	Pros(+)/Cons(-)
Tools and best practices for implementing multiple work shift and/or night work	<ul style="list-style-type: none"> • New technologies (such as intrusion alarms), modified traffic control plans, and new methods to monitor traffic provide improvements in night work zone safety. • These improvements will lead to high nighttime productivity. 	<ul style="list-style-type: none"> + Increases safety for road users and workers + Reduces user costs + Provides faster completion time - Requires research and design costs
Exploitation of web-based team collaboration system	<ul style="list-style-type: none"> • To be efficient, access to information is needed quickly and without hassle. A web-based system can be used to track project deliverables, track project tasks online, receive email alerts as items become due, share documents, and reduce administrative document production and delivery cost by uploading documents. This is handy for CAD drawings or anything else that needs to be shared with the project team. 	<ul style="list-style-type: none"> + Enhances project communication + Eases collaboration with project managers, designers, contractors, vendors, and the public + Keeps everyone in the loop + Allows tracking of project online, which minimizes time taken and enhances performance - Requires high installation and learning costs - Lacks standards
Encouragement of the use of automated construction technologies	<ul style="list-style-type: none"> • Numerous research and implementation efforts are currently under way to automate conventional infrastructure construction, condition assessment, and maintenance activities such as earth moving, compaction, road construction, and maintenance. • Commercial systems are available. 	<ul style="list-style-type: none"> + Results in possible savings + Presents opportunity for significant schedule compression - Requires some training - Requires contractor implementation
Employment of methods for continuous work zones	<ul style="list-style-type: none"> • These methods can be used where road geometry and weekend or night scheduling permit. 	<ul style="list-style-type: none"> + Decreases duration and unit costs + Increases safety - Results in possible higher user costs and traffic congestion
Use of windowed milestone	<ul style="list-style-type: none"> • This method can be used where milestone dates are not based on hard constraints. Milestones should be related to allow the contractor maximum flexibility in efficiently allocating project resources. 	<ul style="list-style-type: none"> + Lowers project costs + Lowers user costs - Reduces ability to "hold contractors' feet to the fire"
Schedule of calendar day projects	<ul style="list-style-type: none"> • Scheduling calendar day projects is applicable to projects where the completion is critical and a large volume of traffic is affected. 	<ul style="list-style-type: none"> + Produces better weather management + Provides a direct method of expediting - Requires strict adherence to the schedule for credibility with the public, even with breakdowns or weather problems
Construction time shortened by full closure of the roadway instead of partial closure	<ul style="list-style-type: none"> • Full closure could be used in areas where there is at least one alternative route for drivers and where volume is limited. 	<ul style="list-style-type: none"> + Shortens construction time - Causes possible traffic congestion on alternative routes
Duration and productivity effects tracked and associated with different technologies	<ul style="list-style-type: none"> • Data collected can be very useful in cost and time estimation for optimal plans. • Technology choices may be limited, however, by project conditions and logical equipment spreads. 	<ul style="list-style-type: none"> + Produces quicker and more dependable exploitation of new technologies - Requires personnel to devote time to properly monitor and record data - Can be perceived as costly
Optimal approaches to crew shifts and scheduling to eliminate long work hours	<ul style="list-style-type: none"> • The schedule can be shortened through use of additional crews on regular shift, multiple shifting, or selective overtime. • Scheduled overtime can be used where appropriate, but effects should be evaluated carefully. 	<ul style="list-style-type: none"> + Provides possible cost savings + Increases productivity + Reduces cycle time of tasks, which improves the schedule - Creates possible negative results if planning is done carelessly - Creates a necessity for contractor to implement
Selected field personnel trained in scheduling methods and claims	<ul style="list-style-type: none"> • Schedule flexibility may be minimal in practice, but for complex jobs a broad understanding of scheduling issues should help expedite progress. 	<ul style="list-style-type: none"> + Creates a flexible and quick-to-adapt project team + Leads to faster project completion - Leads to possibly too many people trying to manage
Lessons-learned database on ways to expedite schedules	<ul style="list-style-type: none"> • This database would be broadly applicable but limited by legal and policy constraints. 	<ul style="list-style-type: none"> + Requires quick reference for implementation of expediting measures - Creates a need for the database to be maintained

SOURCES

REFERENCES

- 3M. 2013. *Geotextile Seaming Cylinder Spray Adhesive*. Tech Data Sheet. Industrial Adhesives and Tapes Division.
- American Association of State Highway Officials (AASHTO). 1962. *The AASHTO Road Test. Report 5 Pavement Research*. Washington, DC: Highway Research Board.
- . 1993. *Guide for Design of Pavement Structures*. 4th ed. Washington, DC: American Association of State Highway and Transportation Officials.
- . 1998. *Supplement to the AASHTO Guide for Design of Pavement Structures*. Washington, DC: American Association of State Highway and Transportation Officials.
- . 2007. *Transportation—Invest in Our Future: A New Vision for the 21st Century*. Washington, DC: AASHTO.
- . (no year). *AASHTOWare Pavement ME Design*. www.aashtoware.org [accessed March 9, 2014]
- ACI Committee 302. 2010. *Guide for Concrete Floor and Slab Construction*. Publication ACI 302-1R-04. Farmington Hills, MI: American Concrete Institute.
- ACI Committee 325. 2006. *Concrete Overlays for Pavement Rehabilitation*. Publication ACI 325.13R-06. Farmington Hills, MI: American Concrete Institute.
- ACI Committed 330. 2008. *Guide for the Design and Construction of Concrete Parking Lots*. Publication ACI 330R-08. Farmington Hills, MI: American Concrete Institute.
- American Concrete Pavement Association (ACPA). 1990a. *Guidelines for Bonded Concrete Overlays*. Technical Bulletin TB-007P. Skokie, IL: American Concrete Pavement Association.
- . 1990b. *Guidelines for Unbonded Concrete Overlays*. Technical Bulletin TB-005P. Skokie, IL: American Concrete Pavement Association.
- . 1991. *Guidelines for Concrete Overlays of Existing Asphalt Pavements (Whitotopping)*. Technical Bulletin TB-009P. Skokie, IL: American Concrete Pavement Association.
- . 1998. *Whitotopping—State of the Practice*. Engineering Bulletin EB210.02P. Skokie, IL: American Concrete Pavement Association.
- . 1999. *Construction Specification Guideline for Ultra-Thin Whitotopping*. Information Series IS120P. Skokie, IL: American Concrete Pavement Association.
- . 2000. *Traffic Management Handbook for Concrete Pavement Reconstruction and Rehabilitation*. Publication EB213P. Skokie, IL: American Concrete Pavement Association.
- . 2012. *Bonded Concrete Overlay on Asphalt (BCOA) Thickness Designer*. (<http://apps.acpa.org/apps/bcoa.aspx>, accessed March 9, 2014)
- . 2012. *StreetPave*. (<http://acpa.org/streetpave>, accessed March 9, 2014)
- . 2013. *National Concrete Overlay Explorer*. (www.overlays.acpa.org/webapps/overlayexplorer/index.html, accessed March 9, 2014)
- Applied Pavement Technology, Inc. 2002a. *Conventional Whitotopping Overlays*. Technical Brief. Publication FHWA IF-03-008. Washington, DC: Federal Highway Administration. (<http://isddc.dot.gov/OLPFiles/FHWA/010933.pdf>, accessed March 10, 2014)
- Applied Pavement Technology, Inc. 2002b. *Unbonded Portland Cement Concrete Overlays*. Technical Brief. Publication FHWA-IF-03-006. Washington, DC: Federal Highway Administration. (<http://isddc.dot.gov/OLPFiles/FHWA/010935.pdf>, accessed March 10, 2014)
- Bordelon, A. C. 2011. *Flowable Fibrous Concrete for Thin Concrete Inlays*. PhD diss., Department of Civil and Environmental Engineering, University of Illinois at Urbana-Champaign. (<https://www.ideals.illinois.edu/handle/2142/29805>, accessed March 10, 2014)
- Bordelon, A. and J. Roesler. 2011. “Flowable Fibrous Concrete for Thin Concrete Inlays.” *1st Transportation and Development Institute Congress 2011*. Ed. I. Al-Qadi and S. Murrell. Chicago, Illinois: American Society of Civil Engineers. pp. 874-883.
- Burnham, T. R. and B. I. Izevbekhai. 2012. Performance of Thin Jointed Concrete Pavements Subjected to Accelerated Traffic Loading at the MnROAD Facility, in *Advances in Pavement Design through Full-scale Accelerated Pavement Testing*, ed. David Jones, John Harvey, Angel Mateos, Imad Al-Qadi, 289–297. Monograph of 4th International Conference on Accelerated Pavement Testing. Boca Raton, FL: CRC Press.
- Cable, J. K. 2012. *Concrete Overlay Field Application Program, Iowa Task Report: US 18 Concrete Overlay Construction under Traffic*. Ames, IA: National Concrete Pavement Technology Center, Iowa State University. (www.intrans.iastate.edu/research/documents/research-reports/US_18_overlay_construction_web.pdf, accessed March 9, 2014)
- Cable, J. K., C. Bauer, E. J. Jaselskis, and L. Li. 2004. *Stringless Portland Cement Concrete Paving*. Iowa Department of Transportation/Iowa Highway Research Board Project TR-490. Center for Portland Cement Concrete Pavement Technology.
- Cervantes, V., and J. R. Roesler. 2009. *Performance of Concrete Pavements with Optimized Slab Geometry*. Final Report, FHWA ICT-09-053. Urbana, IL: Illinois Center for Transportation, University of Illinois.
- Christopher, B. R. 2000. *Maintenance of Highway Edgedrains*. NCHRP Synthesis of Highway Practice 285. Washington, DC: Transportation Research Board. (<http://ntl.bts.gov/lib/17000/17600/17652/PB2001102763.pdf>, accessed March 10, 2014)
- Cole, L. W., and P. A. Okamoto. 1995. Flexural Strength Criteria for Opening Concrete Roadways to Traffic. *Transportation Research Record* 1478:53–61.
- Covarrubias T and Covarrubias V. 2008. TCP Design for Thin Concrete Pavements. *9th International Conference on Concrete Pavements*, San Francisco, CA.
- Covarrubias V, J. P. 2011. Optipave2 v 1.0. (www.tcpavements.com/index.php?op=4_1&lang=en, accessed March 14, 2014)

- Covarrubias V, J. P., Covarrubias, and T. Roesler. 2010. Design of Concrete Slabs with Optimized Geometry. *11th International Symposium on Concrete Roads*, October 20–22, Sevilla, Spain.
- Daleiden, J. 1998. *Video Inspection of Highway Edgedrain Systems*. Publication FHWA SA-98-044. Washington, DC: Federal Highway Administration.
- Federal Highway Administration (FHWA). 1994. *Guidelines for Timing Construction Joint Sawing and Earliest Loading for Concrete Pavements*. Volume 1. FHWA-RD-91-079. Washington, DC: FHWA.
- . 2003a. *Distress Identification Manual for the Long-Term Pavement Performance Program*. 4th revised ed. Publication FHWA RD-03-031. Washington, DC: Federal Highway Administration.
- . 2009. *Manual on Uniform Traffic Control Devices*. 2003 ed. with revisions 1 and 2 incorporated. Washington, DC: Federal Highway Administration.
- Fick, G. 2010. *Concrete Overlay Cost: Frequently Asked Questions*. Concrete Overlay Field Application Program. Ames, IA: National Concrete Pavement Technology Center, Iowa State University.
- Fournier, B., M-A Berube, K. J. Folliard, and M. Thomas. 2010. *Report on the Diagnosis, Prognosis and Mitigation of Alkali-silica Reaction (ASR) in Transportation Structures*. FHWA-HIF-09-004. Washington, DC: Federal Highway Administration. (www.fhwa.dot.gov/pavement/concrete/pubs/hif09004/hif09004.pdf, accessed March 10, 2014)
- Hall, K. T., C. E. Correa, S. H. Carpenter, and R. P. Elliott. 2001. *Rehabilitation Strategies for Highway Pavements*. NCHRP Project C1-38. Washington, DC: Transportation Research Board.
- Harrington, D. 2008. *Guide to Concrete Overlays: Sustainable Solutions for Resurfacing and Rehabilitating Existing Pavements*. 2nd ed. Ames, IA: National Concrete Pavement Technology Center, Iowa State University.
- Harrington, D., D. DeGraaf, R. Riley, R. O. Rasmussen, J. Grove, and J. Mack. 2007. *Guide to Concrete Overlay Solutions*. Ames, IA: National Concrete Pavement Technology Center, Iowa State University.
- Harrington, D., G. Fick, and P. Taylor. 2014 (tentative). *Preservation and Rehabilitation of Urban Concrete Pavements Using Thin Concrete Overlays: Solutions for Joint Deterioration in Cold Weather States*. Ames, IA: National Concrete Pavement Technology Center, Iowa State University.
- Hoerner, T. E., K. D. Smith, H. T. Yu, D. G. Peshkin, and M. J. Wade. 2001. *PCC Pavement Evaluation and Rehabilitation: Reference Manual*. NHI Course 131062. Arlington, VA: National Highway Institute.
- Illinois Department of Transportation—Bureau of Materials and Physical Research (IDOT—BMPR). 2013. *Approved/Qualified Product List of Synthetic Fibers*. Springfield, IL: Illinois DOT. (www.dot.state.il.us/materials/syntheticfibers.pdf, accessed March 10, 2014)
- Kosmatka, S.H., and M. L. Wilson. 2011. *Design and Control of Concrete Mixtures*, 15th Edition. PCA Bulletin EB001.15. Skokie, IL: Portland Cement Association.
- Ley, M.T., R. Felice, and J. M. Freeman. 2012. *Assessment of Air Void System Requirements for Durable Concrete*. Ames, IA: National Concrete Pavement Technology Center, Iowa State University (www.intrans.iastate.edu/research/documents/research-reports/mda_air_void_w_cvr.pdf, accessed March 17, 2014)
- Leykauf, G., and D. Birmann. 2006. Concrete Pavements with Geotextile Interlayer in Germany: Measurements and Long-term Behavior. Proceedings, *10th International Symposium on Concrete Roads*. Brussels, Belgium: European Cement Organisation (CEMBUREAU), World Road Association (PIARC). CD-ROM.
- Mallela, J., G. Larson, T. Wyatt, J. Hall, and W. Barker. 2002. *User's Guide for Drainage Requirements in Pavements: DRIP 2.0 Microcomputer Program*. DTFH61-00-F-00199. Champaign, IL: ERES Consultants. (<http://isddc.dot.gov/OLPFiles/FHWA/010942.pdf>, accessed March 10, 2014)
- Minnesota Department of Transportation (MnDOT). 2013. The Effect of Joint Sealing on the Performance of Thin Whitetopping Sections at MnROAD. *MnROAD [Safer, Smarter, Sustainable Pavements through Innovative Research]*. (www.dot.state.mn.us/mnroad/reports/PDF%27s/jointsealing.pdf, accessed March 10, 2014)
- National Cooperative Highway Research Program (NCHRP). 2004. *Development of the 2002 Guide for the Design of New and Rehabilitated Pavement Structures: Phase II*. NCHRP 01-37A. Washington, DC: Transportation Research Board. (<http://apps.trb.org/cmsfeed/TRBNetProjectDisplay.asp?ProjectID=218>, accessed March 10, 2014)
- . 1982. *Resurfacing with Portland Cement Concrete*. Synthesis 99 (discontinued).
- . 1994. *Portland Cement Resurfacing—A Synthesis of Highway Practice*. Synthesis 204 (discontinued).
- . 2007. *AASHTO Mechanistic-Empirical Design Guide*. Version 1.0 NCHRP Project 1-37a. Washington, DC: Transportation Research Board.
- Okamoto, P.A., P. J. Nussbaum, K. D. Smith, M. I. Darter, T. P. Wilson, C. L. Wu, S. D. Tayabji. 1994. *Guidelines for Timing Contraction Joint Sawing and Earliest Loading for Concrete Pavements*, Volume 1: Final Report. FHWA RD-91-079. Washington, DC: Federal Highway Administration.
- Portland Cement Association. 1984. *Thickness Design for Concrete Highway and Street Pavements*. Skokie, IL: Portland Cement Association.
- Raphael, J. M. 1984. Tensile Strength of Concrete. *ACI Journal* 163:158–165.
- Rasmussen, R. O., and S. I. Garber. 2009. *Nonwoven Geotextile Interlayers for Separating Cementitious Pavement Layers: German Practice and U.S. Field Trials*. International Technology Scanning Program. Washington, DC: Federal Highway Administration.
- Rasmussen, R. O., and D. K. Rozycki. 2004. *Thin and Ultra-Thin Whitetopping*. NCHRP Synthesis of Highway Practice 338. Washington, DC: Transportation Research Board.
- Riley, R. 2006. Modified ACPA Ultra-Thin Whitetopping Design Software.
- Roesler, J., A. Bordelon, A. Ioannides, M. Beyer, and D. Wang. 2008. *Design and Concrete Materials Requirements for Ultra-Thin Whitetopping*. Urbana, IL: University of Illinois at Urbana-Champaign.
- Roesler, J. R., V. G. Cervantes, and A. N. Amirkhanian. 2013. Accelerated Performance Testing of Concrete Pavement with Short Slabs. *International Journal of Pavement Engineering*, doi:10.1080/10298436.2011.575134.
- Simon, E., G. E. Gibson, C. T. Haas, J. T. O'Connor, B. Somali, and Z. Zhang. 2003. *Development of a Tool for Expediting Highway Construction While Retaining Quality*. FHWA/TX-03/4386-1. Austin, TX: Center for Transportation Research, University of Texas at Austin.
- Smith, K. D., H. T. Yu, and D. G. Peshkin. 2002. *Portland Cement Concrete Overlays: State of the Technology Synthesis*. Publication FHWA IF-02-045. Washington, DC: Federal Highway Administration.
- Smith, K. D., T. E. Hoerner, and D. G. Peshkin. 2008 (draft). *Concrete Pavement Preservation Reference Manual*. Ames, IA: National Concrete Pavement Technology Center, Iowa State University.

- Snyder, M. B. 2011. *Guide to Dowel Load Transfer Systems for Jointed Concrete Roadway Pavements*. Ames, IA: National Concrete Pavement Technology Center, Iowa State University.
- Sutter, I., K. Peterson, G. Julio-Betancourt, D. Hooton, T. Van Dam, and K. Smith. 2008. *The Deleterious Chemical Effects of Concentrated Deicing Solutions on Portland Cement Concrete*, Final Report. Publication SD2002-01-F. Pierre, SD: South Dakota Department of Transportation.
- Tayabji, S., J. Anderson, H. Barzegar, G. Fick, E. Gowder, J. Shilstone, P. C. Taylor, and M. Torres. 2007. *Supplemental Report for Proposed Specification for Construction of Concrete Airfield Pavement*. Report IPRF-01-G-002-04-1A. Washington, DC: Innovative Pavement Research Foundation.
- Taylor, P. C., ed. 2006. *Integrated Materials and Construction Practices for Concrete Pavement: A State-of-the-Practice Manual*. Publication FHWA HIF-07-004. Ames, IA: Center for Transportation Research and Education, Iowa State University.
- Taylor, P., R. O. Rasmussen, H. Torres, G. Fick, D. Harrington, and T. Cackler. 2012. *Guide for Optimum Joint Performance of Concrete Pavements*. Ames, IA: National Concrete Pavement Technology Center, Iowa State University.
- TC Pavements. 2010. *Optipave V2.0*. (www.tcpavements.com/index.php?op=0&lang=en, accessed March 10, 2014)
- The Transtec Group. No date. *Material Specifications*. (www.transtecgroup.com/nonwoven-geotextile-interlayers-concrete-pavements/ [search www.concreteontop.com], accessed February 25, 2014)
- Thomas, M. D. A., B. Fournier, K. J. Folliard, and Y. A. Resendez. 2011. *Alkali-Silica Reactivity Field Identification Handbook*. FHWA HIF-12-022. Washington, D.C.: Federal Highway Administration.
- Torres, H. N., J. Roesler, R. O. Rasmussen, and D. Harrington. 2012. *Guide to the Design of Concrete Overlays Using Existing Methodologies*. FHWA Project DTFH61-06-H-00011 (Work Plan 13). Ames, IA: National Concrete Pavement Technology Center, Iowa State University.
- Trevino, M., B. F. McCullough, and D. W. Fowler. 2004. *Techniques and Procedures for Bonded Concrete Overlays*. FHWA/TX-05/0-4398-2. Austin, TX: Center for Transportation Research, University of Texas at Austin.
- Van Dam, T., P. Taylor, G. Fick, D. Gress, M. Van Geem, and E. Lorenz. 2012. *Sustainable Concrete Pavements: A Manual of Practice*. Ames, IA: National Concrete Pavement Technology Center, Iowa State University. (www.cptechcenter.org/technical-library/documents/Sustainable_Concrete_Pavement_508.pdf, accessed March 10, 2014)
- Vandenbossche, J. M. and M. Barman. 2010. Whitetopping Overlay Design Considerations for the Development of Reflective Cracks and Joint Sealing. In *Transportation Research Record: Journal of the Transportation Research Board*.
- Vandenbossche, J., N. Dufalla, and Z. Li. 2012. *A Revised Thin and Ultra-Thin Bonded Whitetopping Design Procedure*. Presented at 2013 TRB Annual Meeting.
- Vandenbossche, J. 2013. *BCOA ME*. Swanson School of Engineering, University of Pittsburgh. (www.engineering.pitt.edu/Vandenbossche/BCOA-ME_DesignGuide/, accessed March 10, 2014)
- Wade, M. J., G. D. Cuttell, J. M. Vandenbossche, K. D. Smith, M. B. Snyder, and H. T. Yu. 1995. *Performance of Concrete Pavements Containing Recycled Concrete Aggregate*. Report No. DTFH61-93-C-000133-Task B. Interim Report. Washington, DC: Federal Highway Administration.
- Walker, W. W. and J. A. Holland. 2007. Performance-Based Dowel Design: Lift-truck design changes require a new look at joint durability. In *Concrete Construction* Jan. 2007.
- Yurdakul, E. 2010. *Optimizing concrete mixtures with minimum cement content for performance and sustainability*. MS Thesis. Ames, IA: Iowa State University.

SOURCES

BIBLIOGRAPHY

- AASHTO. 1993. *Guide Specifications for Highway Construction*. Washington, DC: American Association of State Highway and Transportation Officials.
- . 2002. *Guide for Design of New and Established Pavement Structures*. Washington, DC: Transportation Research Board.
- American Concrete Pavement Association (ACPA). 2000. *Repair of Ultra-Thin Whitetopping: Roadways and Airfields*. Publication PA397P. Skokie, IL: American Concrete Pavement Association.
- . 2006. *Concrete Pavement Field Reference: Preservation and Repair*. Publication EB 239 P. Skokie, IL: American Concrete Pavement Association.
- . 2007. *Subgrades and Subbases for Concrete Pavements*. EB204P. Skokie, IL: American Concrete Pavement Association.
- . 1999. *Ultra-Thin Whitetopping*. Information Series IS100.02P. Skokie, IL: American Concrete Pavement Association.
- . 2007. *Concrete Intersections: A Guide for Design and Construction*. TB019P. Skokie, IL: American Concrete Pavement Association.
- . 2008. *Concrete Pavement Field Reference: Pre-Paving*. EB237P. Skokie, IL: American Concrete Pavement Association.
- Altoubat, S. A., J. R. Roesler, D. A. Lange, and K.-A. Rieder. 2008. Simplified Method for Concrete Pavement Design with Discrete Structural Fibers. *Construction and Building Materials* 22 (3): 384–393.
- Anderson, S. D., G. L. Ullman, and B. C. Blaschke. 2002. *A Process for Selecting Strategies for Rehabilitation of Rigid Pavements*. NCHRP Project 10-50A. Washington, DC: Transportation Research Board.
- Cable, J. K., M. L. Anthony, F. S. Fanous, and B. M. Phares. 2006. *Evaluation of Composite Pavement Unbonded Overlays*. IHRB Project TR-478. Ames, IA: Iowa State University.
- Cable, J. K., L. E. Edgar, and D. R. Anderson. 2005. *Ultra-Thin Portland Cement Concrete Overlay Extended Evaluation*. IHRB Project TR-432. Ames, IA: Iowa State University.
- Cable, J. K., F. S. Fanous, H. Ceylan, D. Wood, D. Frentress, T. Tabbert, S.-Y. Oh, and K. Gopalakrishnan. 2005. *Design and Construction Procedures for Concrete Overlay and Widening of Existing Pavements*. IHRB Project TR-511. Ames, IA: Iowa State University.
- Cable, J. K., J. M. Hart, and T. J. Ciha. 2001. *Thin Bonded Overlay Evaluation*. IHRB Project HR-559. Ames, IA: Iowa State University.
- Delatte, N., S. Chen, J. Davidson, A. Sehdev, N. Amer, and M. Endfinger. 2001. *Design and Quality Control of Concrete Overlays*. UTCA Report 01220. Tuscaloosa, AL: University Transportation Center for Alabama.
- ERES Consultants. 1999. *Evaluation of Unbonded Portland Cement Concrete Overlays*. NCHRP Report 415. Washington, DC: Transportation Research Board.
- Federal Highway Administration (FHWA). 1992. *Drainable Pavement Systems, Participant Notebook*. FHWA-SA-92-008. Washington, DC: Federal Highway Administration.
- . 1999. *Pavement Preventive Maintenance Reference Manual*. Washington, DC: Federal Highway Administration.
- . 2000. *Insights into Pavement Preservation: A Compendium*. Washington, DC: Federal Highway Administration.
- . 2001a. *Pavement Preservation: Selecting Pavements for Preventive Maintenance*. NHI Course 131058. Washington, DC: Federal Highway Administration.
- . 2001b. *PCC Pavement Evaluation and Rehabilitation*. NHI Course 131062. Washington, DC: Federal Highway Administration.
- . 2004. *Pavement Preservation: Integrating Pavement Preservation Practices and Pavement Management*. NHI Course 131104. Washington, DC: Federal Highway Administration.
- . 2007. *Thin Whitetopping—The Colorado Experience*. FHWA-HIF-07-025. Washington, DC: Federal Highway Administration.
- . 2012. *Alkali-Silica Reactivity Field Identification Handbook*. FHWA-HIF-12-022. Washington, DC: Federal Highway Administration.
- Mack, J. W., L. D. Hawbaker, and L. W. Cole. 1998. Ultrathin Whitetopping: State-of-the-Practice for Thin Concrete Overlays of Asphalt. *Transportation Research Record* 1610:39–43.
- Mathis, D. M. 1990. Pavement Drainage Rehabilitation. *Proceedings, Virginia Pavement Drainage Workshop*. Williamsburg, VA: Virginia Department of Transportation.
- McGhee, K. H. 1994. *Portland Cement Concrete Resurfacing*. NCHRP Synthesis of Highway Practice 204. Washington, DC: Transportation Research Board.
- National Cooperative Highway Research Program (NCHRP). 2005. Versions 0.900 and 1.0 of the M-E Pavement Design Software. NCHRP Project 1-40A. Washington, DC: Transportation Research Board.
- . 2006. Technical Assistance to NCHRP and NCHRP Project 1-40a. NCHRP Project 1-40d. Washington, DC: Transportation Research Board.
- . 2007. *AASHTO Mechanistic-Empirical Design Guide. Version 1.0*. NCHRP Project 1-37a. Washington, DC: Transportation Research Board.
- Rasmussen, R. O. 2008. *Geotextile Interlayers for Separating Cementitious Pavement Layers: European Practice and U.S. Field Trials*. Washington, DC: Federal Highway Administration and Transtec Group, Inc.
- Riley, R. C., A. Gotlif, and J. Mallela. 2005a. Whitetopping: Atypical is Typical. *Proceedings of the International Conference on Best Practices for Ultrathin and Thin Whitetoppings*. Denver, CO, April 12–15.
- Riley, R. C., L. Titus-Glover, J. Mallela, S. Waalkes, and M. Darter. 2005b. Incorporation of Probabilistic Concepts into Fatigue Analysis of Ultrathin Whitetopping as Developed for the American Concrete Pavement Association. *Proceedings of the International Conference on Best Practices for Ultrathin and Thin Whitetoppings*. Denver, CO, April 12–15.

- Roesler, J. R. 2004. Fracture of Plain and Fiber-reinforced Concrete Slabs under Monotonic Loading. *Journal of Materials in Civil Engineering* 16 (5): 452–460.
- Roesler, J. R. 2007. Design and Specification of Concrete Pavements with Structural Fibers. Paper presented at the International Workshop on Best Practices for Concrete Pavements, Recife, Brazil.
- Sheehan, M. J., S. M. Tarr, and S. D. Tayabji. 2004. *Instrumentation and Field Testing of Thin Whitetopping Pavements in Colorado and Revision of the Existing Colorado Thin Whitetopping Procedure*. Report CDOT-DTD-R-2004-12. Denver, CO: Colorado Department of Transportation.
- Tarr, S. M., M. J. Sheehan, and P. A. Okamoto. 1998. *Guidelines for the Thickness Design of Bonded Whitetopping Pavements in the State of Colorado*. Report CDOT-DTD-R-98-10. Denver, CO: Colorado Department of Transportation.
- Titus-Glover, L., J. Mallela, M. I. Darter, G. Voigt, and S. Waalkes. 2005. Enhanced Portland Cement Concrete Fatigue Model for StreetPave: Rigid and Flexible Pavement Design 2005. *Transportation Research Record* 1919:29–37.
- Vandenbossche, J. M., and A. J. Fagerness. 2002. Performance, Analysis, and Repair of Ultrathin and Thin Whitetopping at Minnesota Road Research Facility. *Transportation Research Record* 1809:191–198.
- VDOT. 1990. *Guidelines for Providing Improved Drainage Systems for VDOT Pavement Structures*. Charlottesville, VA: Virginia Department of Transportation.
- Winkelman, T. J. 2002. *Bonded Concrete Overlay Performance in Illinois*. Report FHWA/IL/PRR 143. Springfield, IL: Illinois Department of Transportation.
- Wu, C.-L., S. M. Tarr, T. M. Refai, M. A. Nagi, and M. J. Sheehan. 1999. *Development of Ultra-Thin Whitetopping Design Procedure*. PCA R&D Serial 2124. Skokie, IL: Portland Cement Association.
- Wells, G. K., and S. M. Wiley. 1987. *The Effectiveness of Portland Cement Concrete Pavement Rehabilitation Techniques*. FHWA/CA/TL-87/10. Washington, DC: Federal Highway Administration.
- Young, B. 1990. *Evaluation of the Performance of Fin Drains in Georgia*. FHWA-GA-90-8709. Atlanta, GA: Georgia Department of Transportation.

MEMO

A series of horizontal dotted lines for writing.

MEMO

A series of horizontal dotted lines for writing.

National Concrete Pavement
Technology Center



2711 South Loop Drive, Suite 4700
Ames, IA 50010-8664
515-294-5798
www.cptechcenter.org